



Gruppi autonomi di raffreddamento
Serie RID
Offline cooling units
RID series



APPLICAZIONE

APPLICATION

Applicazioni

- > Impiantistica oleodinamica
- > Riduttori
- > Macchine utensili
- > Macchine industriali

Application

- > Hydraulic installations
- > Planetary reduction gears
- > Machine tools
- > Industrial machinery





DESCRIZIONE

Per il settore dei riduttori EMMEGI ha realizzato una nuova unità ausiliaria di raffreddamento e filtrazione RID, composta da scambiatore di calore aria/olio motore elettrico, pompa idraulica (vite per RID55/56 e ingranaggi per gli altri modelli), ventola.

Può essere dotato di quadro elettrico di potenza con termostato per l'avviamento della pompa; termostato di allarme per raggiunta sovratemperatura; pressostato per il controllo della pressione in carcassa; filtro SPIN/ON.

IL gruppo autonomo RID può essere usato per raffreddare altre tipologie di circuito su impianti stazionari.

DESCRIPTION

EMMEGI have designed a new cooling system unit with filter called RID and intended for the planetary reduction gear marker.

The RID consists of an high efficiency air/oil heat exchanger an electric motor, a hydraulic pump (screw for RID55/56 and gears for other models) and a fan.

It can be supplied with:

a power electric box with a thermostat to turn on and off the pump;

alarm thermostat for over temperature;

control pressure switch (to be applied to the reduction tank);

SPIN/ON filter.

The RID cooling system unit can be employed to cool different types of stationary system circuits as well.

SCHEMA IDRAULICO HYDRAULIC CIRCUIT

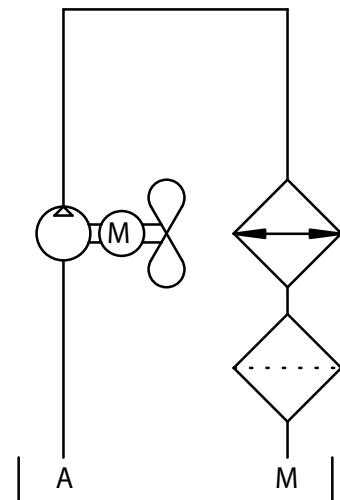



Riduttore orizzontale
Horizontal gear unit

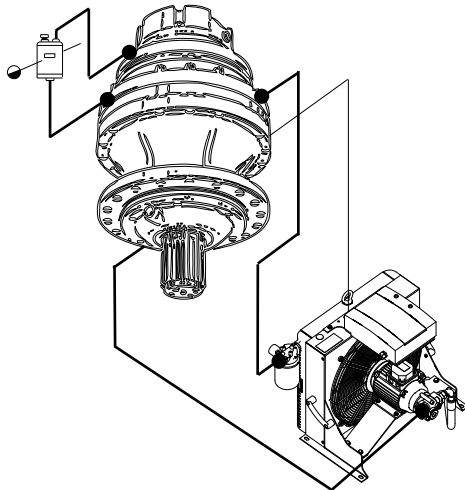
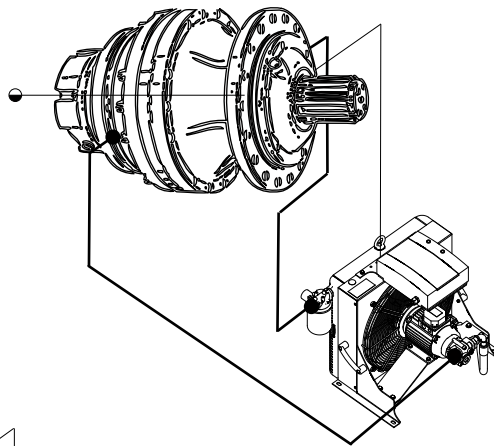

Riduttore verticale in linea ed ortogonale
In-line and right-angle vertical gear unit

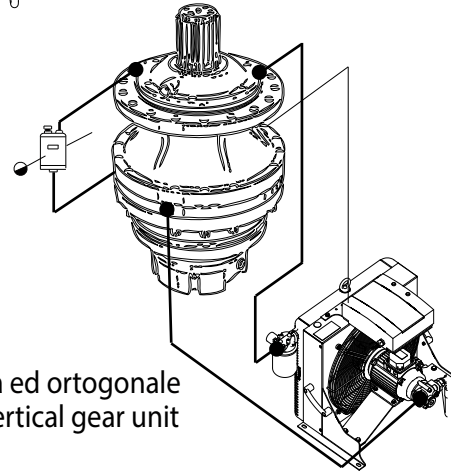

E' richiesto il preriempimento dei tubi quando lo scambiatore non e' sotto battente.

MANUTENZIONE

PULIZIA LATO ARIA:

Può essere effettuata mediante aria compressa o acqua, con la direzione del getto parallelo alle alette.

Una pulizia più energica si ottiene con l'aggiunta di un prodotto detergente.

Se l'accumulo di sporco è causato da olio o da grasso, la pulizia potrà essere fatta con un getto di vapore o di acqua calda, facendo sempre attenzione alla direzione del getto.

Durante le operazioni di pulizia, il motore elettrico dovrà essere disinserito e convenientemente protetto.

PULIZIA LATO OLIO:

Per compiere questo tipo di pulizia, lo scambiatore deve essere smontato e flussato in controcorrente con perclorotilene per un periodo che va dai 10' min. ai 20' min.

Procedere quindi allo svuotamento del circuito interno con aria compressa, prestando attenzione che la pressione non superi la massima ammessa dallo scambiatore.

Effettuare un prelavaggio interno prima di collegarlo all'impianto.

We would recommend to fullfill the hoses when the unit is installed higher than the tank level.

MAINTENANCE

AIR SIDE CLEANING

Can be done through means of compressed air or water, with the direction of the jet moving parallel to the channels.

More thorough cleaning can be carried out using detergent.

If the accumulations of dirt is caused by oil or grease, then it can be carried out with a jet of steam or hot water, always paying attention to the direction of the jet.

During the cleaning operation, the electric motor must be disconnected and properly protected.

OIL SIDE CLEANING

To carry out this type of cleaning, the heat exchanger must be dismantled and flushed out with a counter-current of perchloride for a period of 10/20 minutes.

Then flush out the system with compressed air, paying particular attention to the pressure not more than the maximum allowed for the heat exchanger.

We suggest to do a internal pre-washing before connecting to the system.



DENOMINAZIONE CODICE PRODOTTO

ORDERING CODE

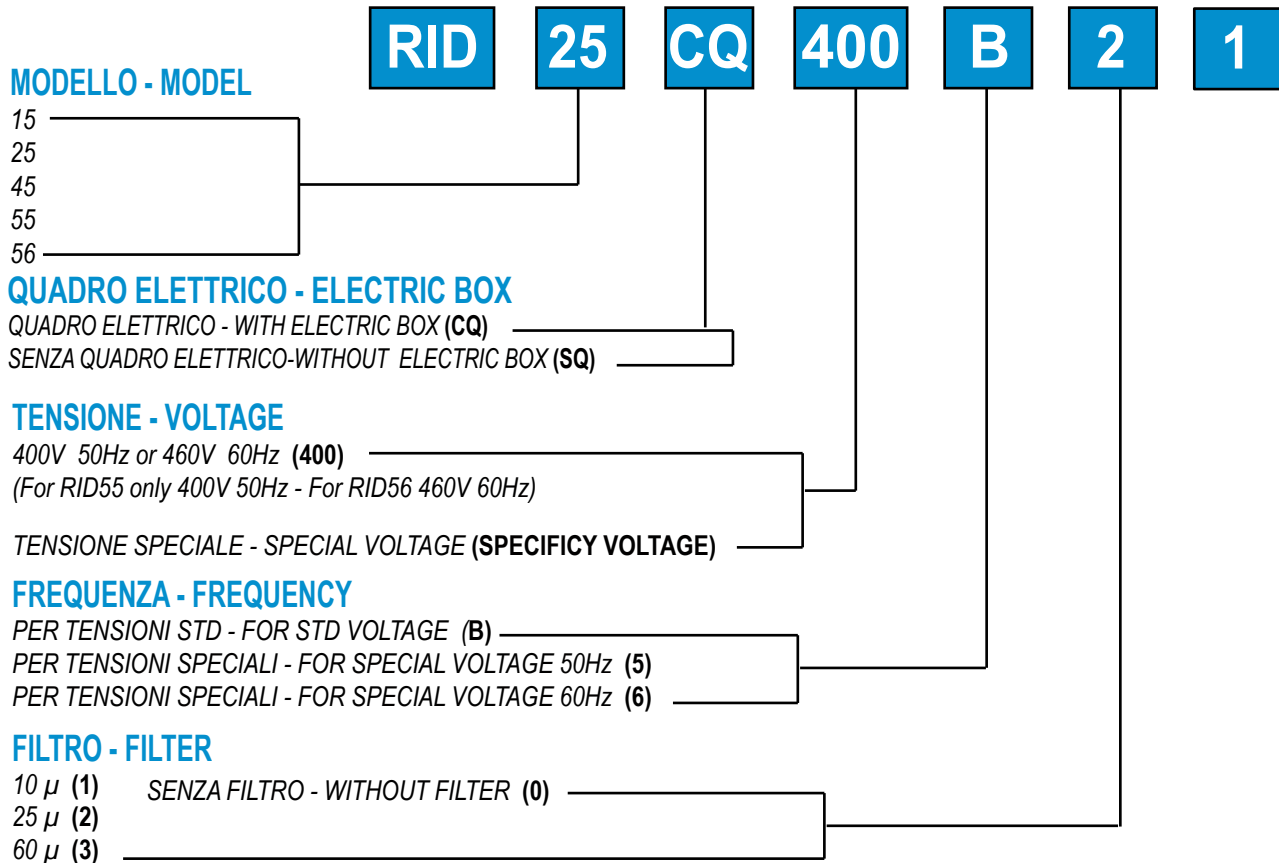

COLLEGAMENTO ELETTRICO - ELECTRIC WIRING

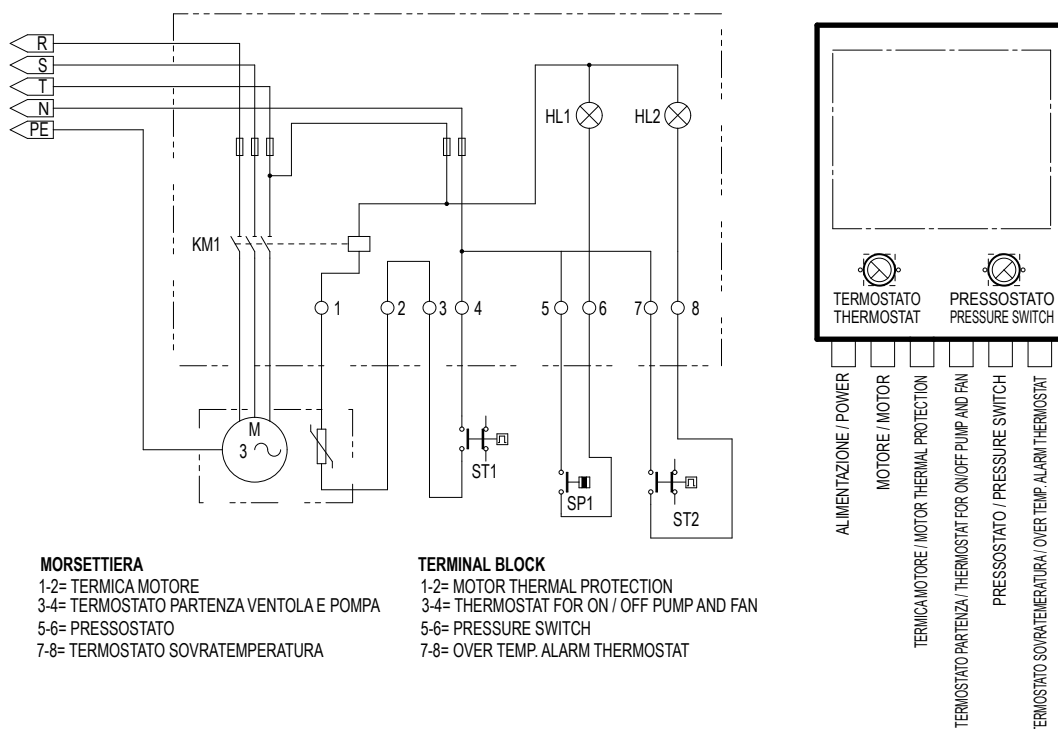



DATI TECNICI

TECHNICAL DATA

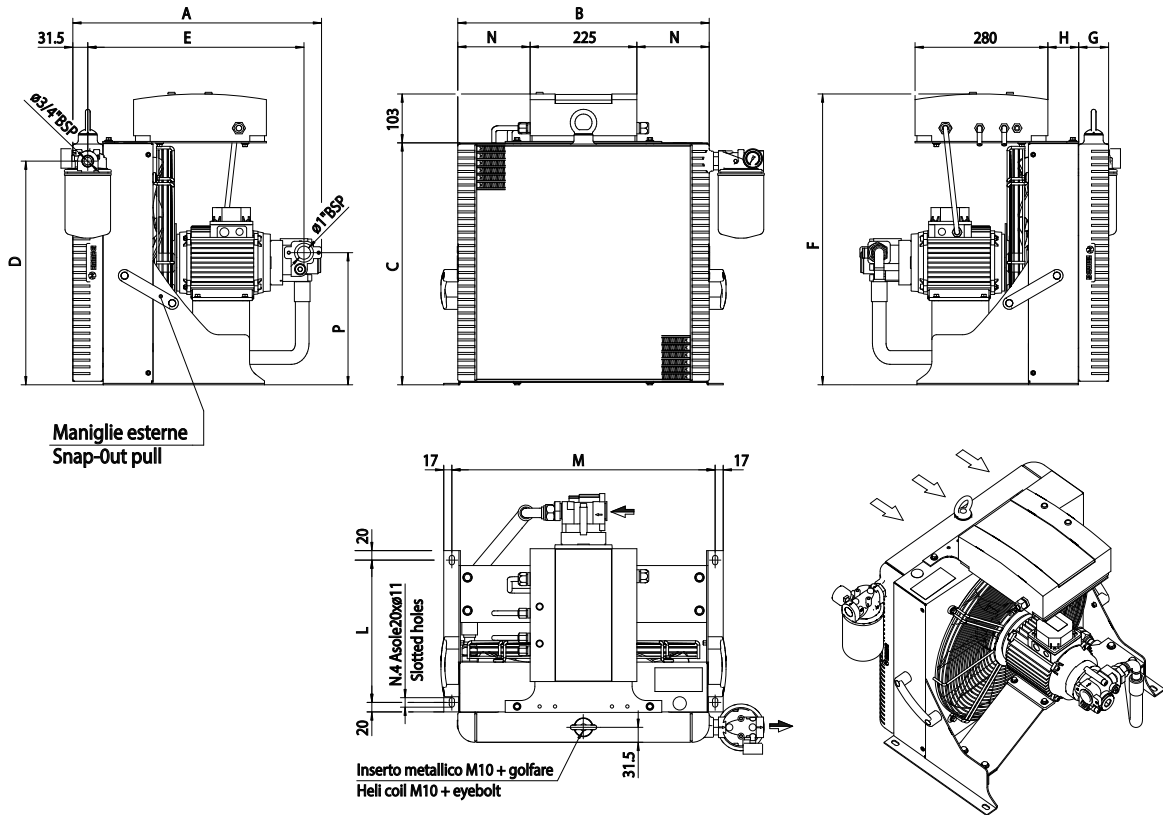

La versione con quadro elettrico è comprensiva di :

- Termostato fisso IP65 - TM46/A1 60-48°C
- Termostato fisso IP65 - TM49/A1 90-78°C
- N°4 Antivibranti Ø 30 L=20mm. M8
- 5 Metri di cavo

With electric box version the supply includes :

- Thermostat integrated IP65 - TM46/A1 60-48°C
- Thermostat integrated IP65 - TM49/A1 90-78°C
- N°4 Anti-vibration Ø 30 L=20mm. M8
- 5 Mt.cable

TYPE	A	B	C	D	E	F	G	H	L	M	N	P
RID 15	512	310	312	273.5	442.5	415	63	35.5	280	347	42.5	179.5
RID 25	515	370	360	316.5	446.5	503	63	55	280	400	55	201
RID 45	524	530	510	471.5	456	611	63	65	300	555	152.2	278.5
RID 55	632	650	609	570.5	560.5	712	63	65	380	695	211	305
RID 56	688	650	609	570.5	617	712	63	65	380	695	211	305

Per tensioni speciali contattare EMMEGI - For special voltage contact EMMEGI

TYPE	V	KW	A	Oil Flow (lpm)	Air Flow (m ³ /h)	Kg (max)	Index of protection
RID 15	400 V 50 Hz / 460 V 60 Hz	0.95 / 1.1	2.1 / 2.0	10	700	28	IP 55
RID 25	400 V 50 Hz / 460 V 60 Hz	0.95 / 1.1	2.1 / 2.0	10	1630	30	IP 55
RID 45	400 V 50 Hz / 460 V 60 Hz	0.95 / 1.1	2.1 / 2.0	10	4100	47	IP 55
RID 55	400V 50 Hz	1.1	3.6	23	6048	57	IP 55
RID 56	460V 60Hz	2.2	609	28	7250	68	IP 55

Le dimensioni di ingombro e le caratteristiche tecniche non sono impegnative
Over-all dimensions and technical characteristic are not binding



DIAGRAMMA RENDIMENTO (ISO VG 150 @ 80°C)

PERFORMANCE DIAGRAM (ISO VG 150 80°C)

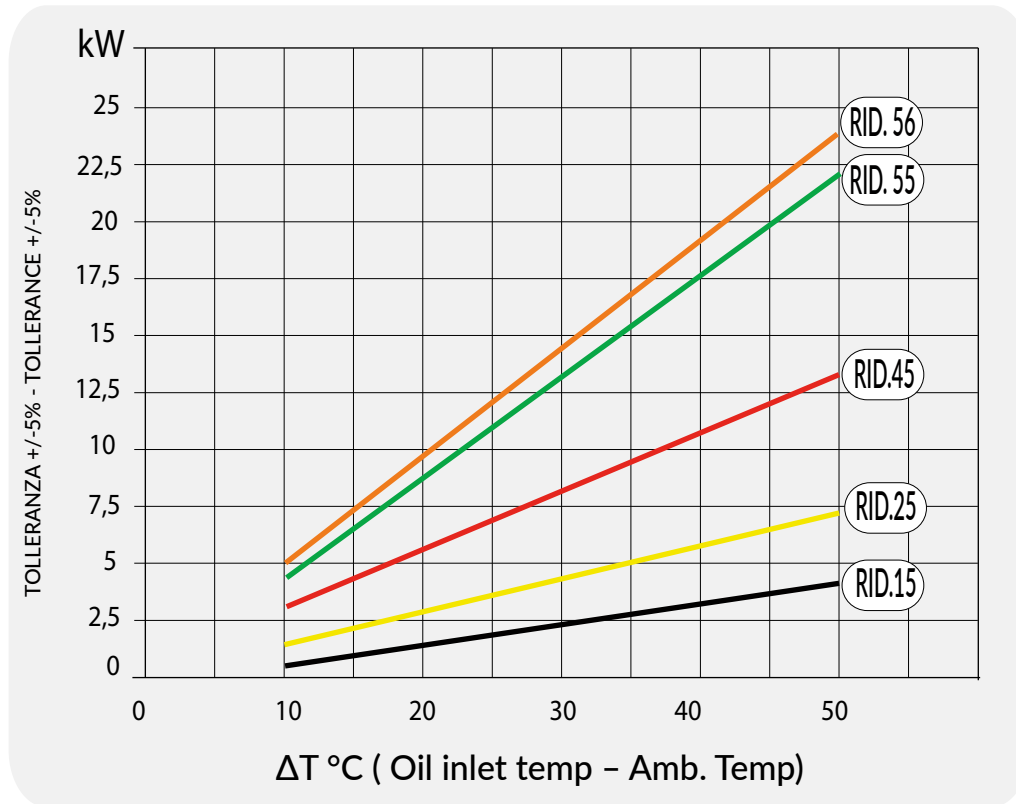

LIVELLO RUMORE db (A)

NOISE LEVEL db (A)

