



Miniature Piston Pumps 5 Piston & Cartridge Design

Pressures to 276 bar (4000 psi)

Displacements from .156 to .865cc/rev (.01 to .05 in³/rev)

aerospace
climate control
electromechanical
filtration
fluid & gas handling
hydraulics
pneumatics
process control
sealing & shielding



ENGINEERING YOUR SUCCESS.

 **WARNING**

FAILURE OR IMPROPER SELECTION OR IMPROPER USE OF THE PRODUCTS AND/OR SYSTEMS DESCRIBED HEREIN OR RELATED ITEMS CAN CAUSE DEATH, PERSONAL INJURY AND PROPERTY DAMAGE.

This document and other information from Parker Hannifin Corporation, its subsidiaries and authorized distributors provide product and/or system options for further investigation by users having technical expertise. It is important that you analyze all aspects of your application and review the information concerning the product or system in the current product catalog. Due to the variety of operating conditions and applications for these products or systems, the user, through its own analysis and testing, is solely responsible for making the final selection of the products and systems and assuring that all performance, safety and warning requirements of the application are met.

The products described herein, including without limitation, product features, specifications, designs, availability and pricing, are subject to change by Parker Hannifin Corporation and its subsidiaries at any time without notice.

Offer of Sale

The items described in this document are hereby offered for sale by Parker Hannifin Corporation, its subsidiaries or its authorized distributors. This offer and its acceptance are governed by the provisions stated in the "Offer of Sale".

© Copyright 2016 Parker Hannifin Corporation, All Rights Reserved



Parker Hannifin
HPS Division
New Hope, MN 55428 USA

Miniature Piston Pumps: Pumping Efficiencies up to 90% Allow Effective Use of .156 to .865 cc/rev Piston Pumps at Pressures to 276 bar (4000 psi)

Breakthrough designs come and go, succeed and fail. The really good designs pass the test of time and continue to succeed. The Oildyne Division mini pump is one of these good designs.

Mini pumps handle hydraulic oil, brake fluid, ultra-low viscosity fluids and many non-water based fluids with equal ease. Need greater versatility? These fixed displacement axial piston pumps are efficient and powerful too. Tests run on 15.1 cSt (78 SSU) fluid at 38°C (100°F) at 207 bar (3000 psi) showed a 90% volumetric

efficiency. Capable of 276 bar (4000 psi) operation, mini pumps are available in nine displacements ranging from .156 to .865 cc/rev (.01 to .053 in³/rev).

Compact size, versatility, efficiency, power and speed are combined in a very competitive package in the Oildyne mini pumps. They're suitable for many applications requiring compact power including automotive, marine, medical and military uses.

Mini Pump Features

- .156 to .865 cc (.01 to .053 in³) displacement per revolution
- Designed for open circuit systems
- Fixed displacement – Output flow is determined by motor drive speed.
- Operating temperature range: -40° to +149°C (-40° to 300°F)
- Inlet port on side or rear
- Will operate efficiently on extremely thin (5 cSt) fluid
- Tandem pumps, special configurations and bi-rotational pumps are available.

Cartridge Piston Pumps: Compact Fluid Power Redefined by the Oildyne Division.

This cartridge piston pump raises the standard for compact fluid power! This three-piston cartridge style pump is an efficient, fixed displacement pump that provided high performance at a very economical price. Pressure ratings up to 276 bar (4000 psi), driven speeds up to 5000 RPM, and the ability to provide a variety of seal types make this the solution to your unique application. This uni-rotational pump is capable of pumping non-water based fluids ranging in viscosity from solvents to thick fluids.

The three-piston cartridge pump maintains the performance and flexibility of the Oildyne five-piston, standalone pump while reducing the overall package dimensions.

This ultra-compact cartridge piston pump, approximately

33 mm (1.3 in) in diameter and 51 mm (2 in) long, is designed to fit into your specially machined manifold allowing for a custom package that fits your space needs.

Three standard displacements are available all within the existing physical size. (The internal cam angle determines the displacement).

Contact Oildyne Division for a drawing showing the cavity details as well as the motor shaft and flange details needed for your motor to drive and mount this pump to your manifold.

Cartridge Pump Features

- .1 to .33 cc (.006 to .020 in³) displacement per revolution
- Designed for manifold mounting
- Fixed displacement – Output flow is determined by motor drive speed.
- Operating temperature range: -40° to +149°C (-40° to 300°F)
- Will operate efficiently on extremely thin (5 cSt) fluid
- Counter clockwise rotation (from pump drive end)

See Page 34 for Cartridge Pump ordering code

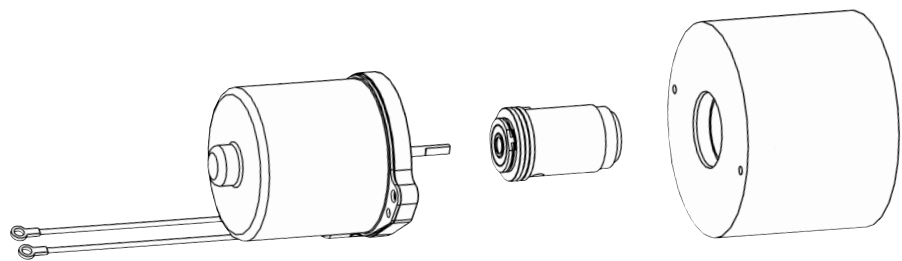

Your Motor

Pump

Your Manifold Package

Miniature Piston Pump Standard Product Model Code

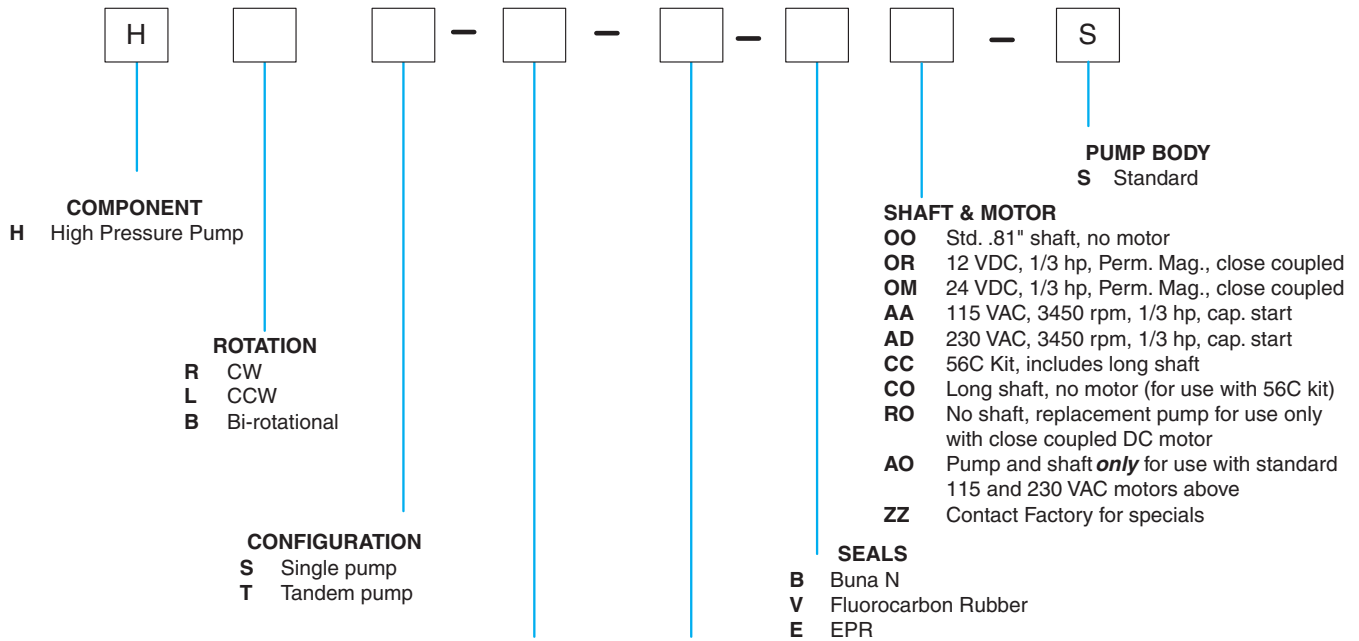

1st PUMP SIZE		2nd PUMP SIZE	
CODE	DISP.	CODE	DISP.
156	.156 cc/rev	156	.156 cc/rev
206	.206 cc/rev	206	.206 cc/rev
259	.259 cc/rev	259	.259 cc/rev
311	.311 cc/rev	311	.311 cc/rev
346	.346 cc/rev	346	.346 cc/rev
417	.417 cc/rev	417	.417 cc/rev
519	.519 cc/rev	519	.519 cc/rev
692	.692 cc/rev	692	.692 cc/rev
865	.865 cc/rev	865	.865 cc/rev

Notes:

1. Tandem pumps must have the larger displacement called out first
2. Tandem pumps are not available with the standard AC or DC motors - only standard shaft or 56C kit
3. Drive shaft input torque must be under 3.5 Nm (525 in-oz) (equivalent to HRS865 operating at 207 bar (3000 psi); refer to catalog performance curves for torque data)
4. Bi-rotational pumps require the side port as case drain
5. For configurations not shown above please contact Oildyne

Miniature Piston Pump Basic Specifications

Model	156	206	259	311	346	417	519	692	865
Displacement									
In ³ per rev.	.0095	.0126	.0158	.0190	.0211	.0255	.0317	.0422	.0527
cc /rev	.156	.206	.259	.311	.346	.417	.519	.692	.865
Max RPM @ rated pressure W/O supercharge	4400	4200	4000	3800	3800	3700	3700	3600	3500
Operating Pressure (psi)									
Continuous bar (psi)	241 (3500)	241 (3500)	241 (3500)	241 (3500)	241 (3500)	241 (3500)	241 (3500)	224 (3250)	207 (3000)
Intermittent bar (psi)	258 (3750)	258 (3750)	258 (3750)	258 (3750)	258 (3750)	258 (3750)	258 (3750)	241 (3500)	241 (3500)
Maximum bar (psi)	276 (4000)	276 (4000)	276 (4000)	276 (4000)	276 (4000)	276 (4000)	276 (4000)	258 (3750)	241 (3500)

Performance Data

Performance data shown are the average results based upon a series of laboratory tests of production units and are not necessarily representative of any one unit. Tests were run with 15.1 cSt (78 SSU) fluid.

In accordance with our policy of continuing product development, we reserve the right to change specifications shown without notice.

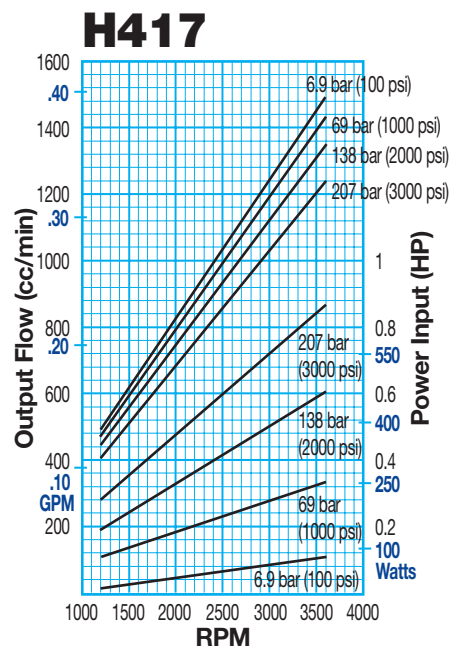
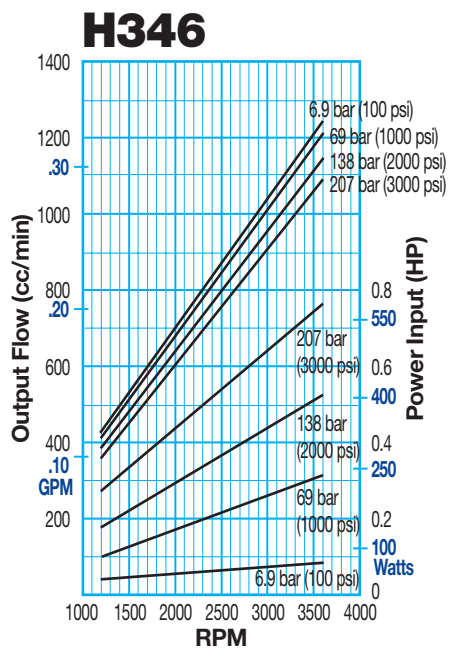
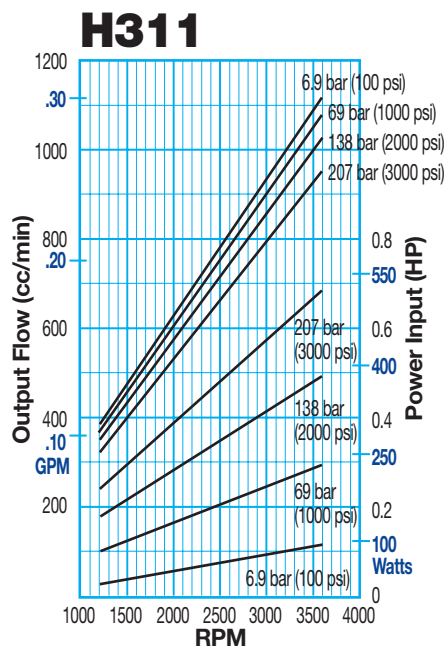
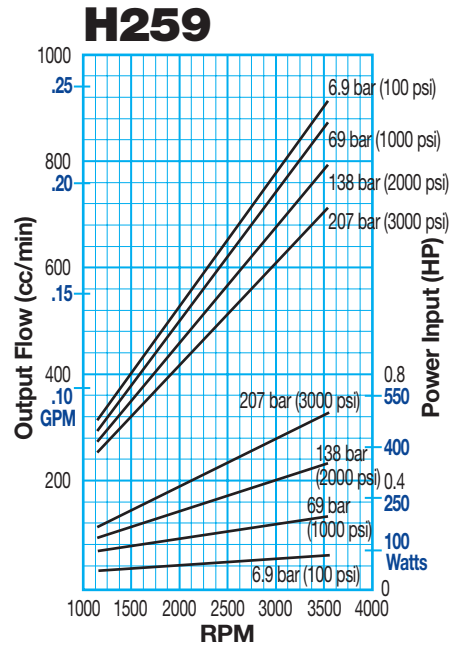
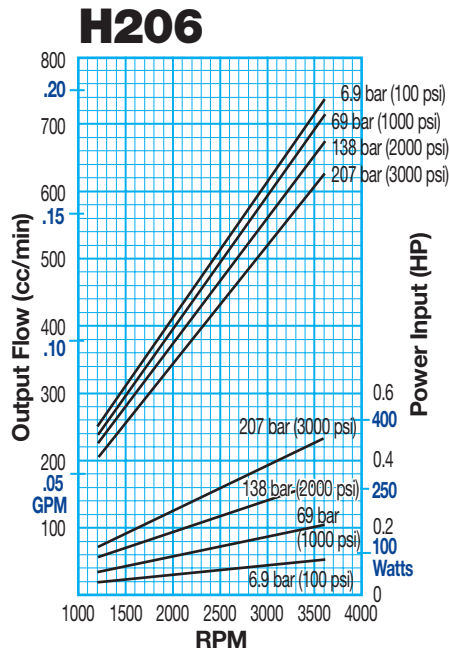
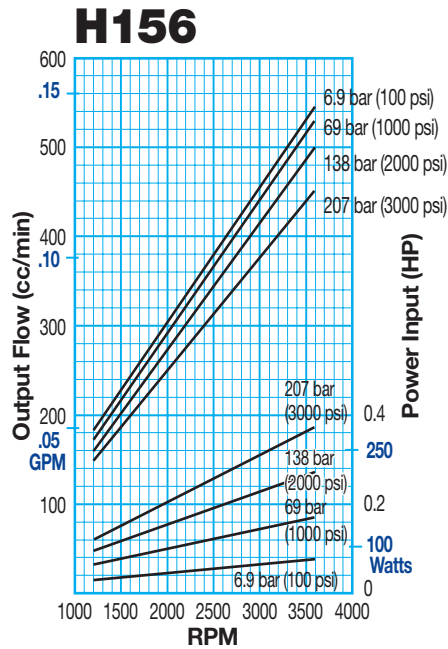

Note: Performance data is for reference only.

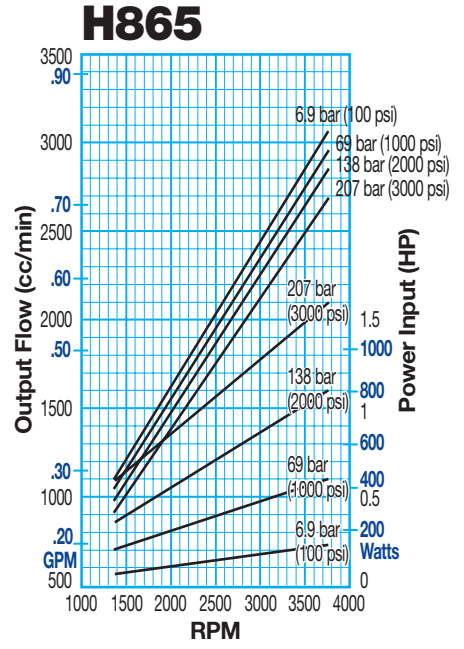
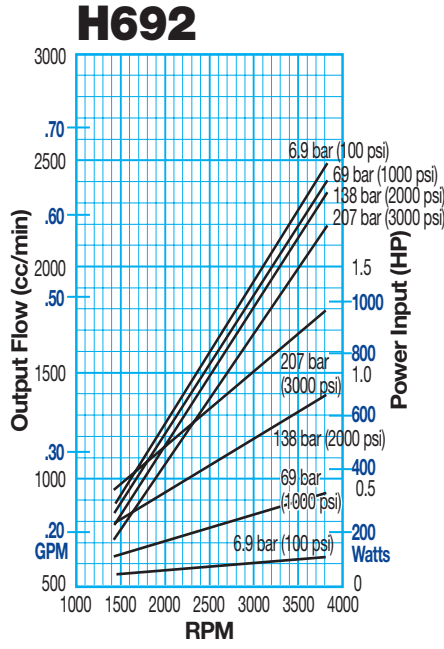
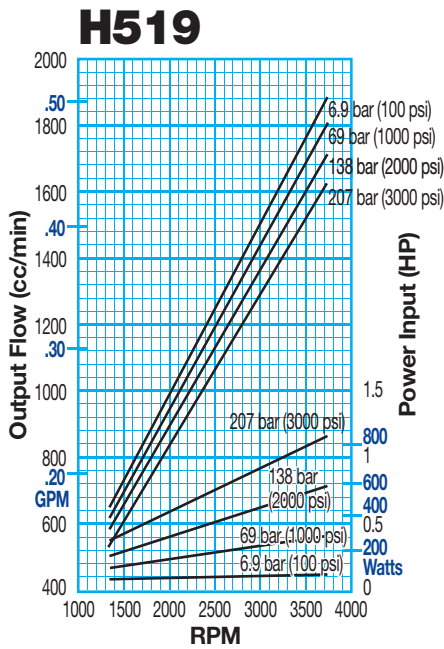

Typical Performance Data

at 12 VDC as assembled with a standard DC motor

NOTE: 24 VDC motor current will be approximately 1/2 of the 12 VDC current shown here. Max current for continuous operation is:
 12 VDC: 12.6 A
 24 VDC: 9.6 A

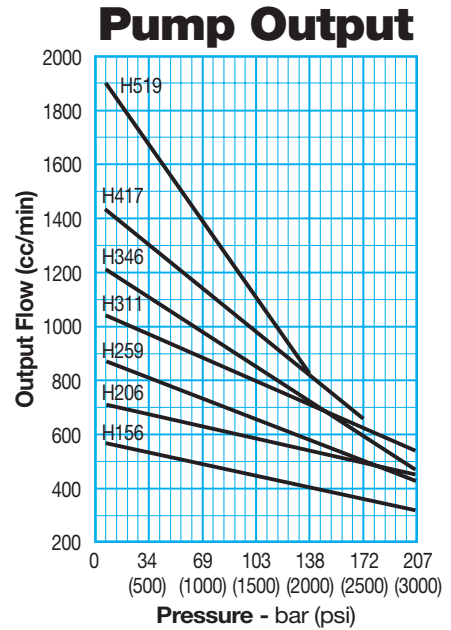
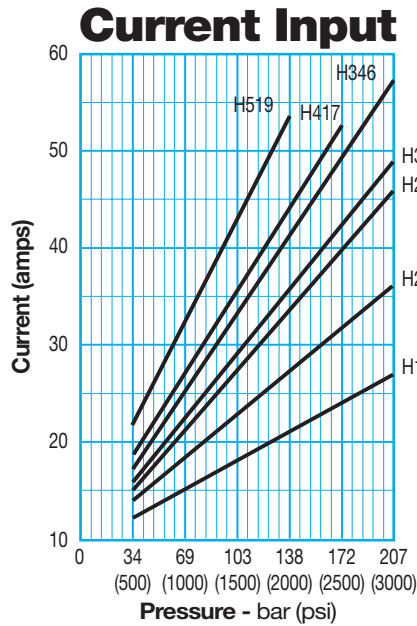

Average Input Torque

Speed: 3000 RPM

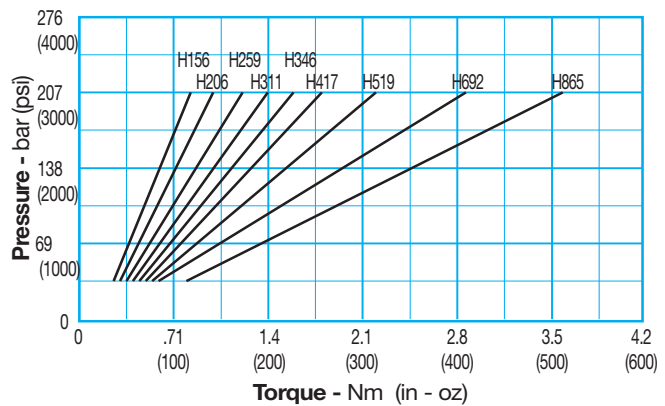

Note: Performance data is for reference only.



Performance Data

DC Motor Duty Cycle Characteristics

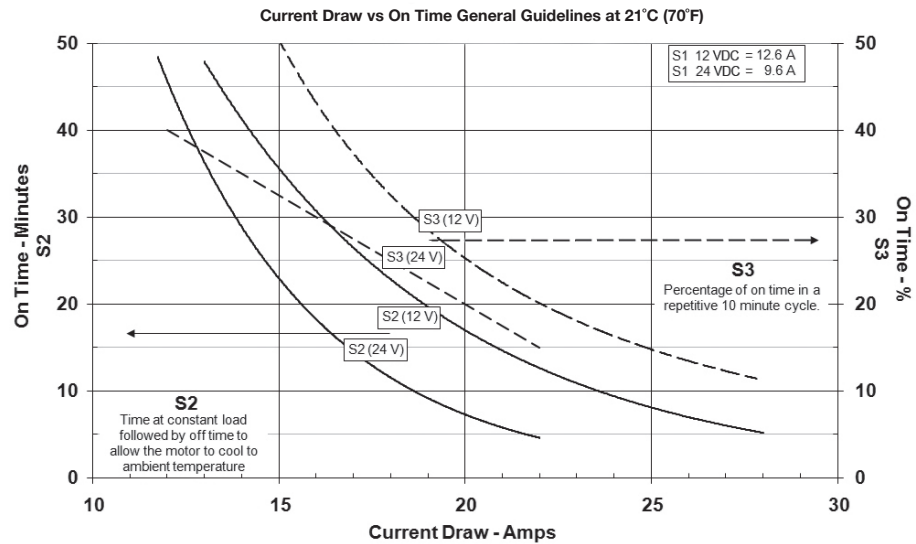

AC Motor and Miniature Piston Pump Performance

115 VAC Motor Flow Rate 60 Hz

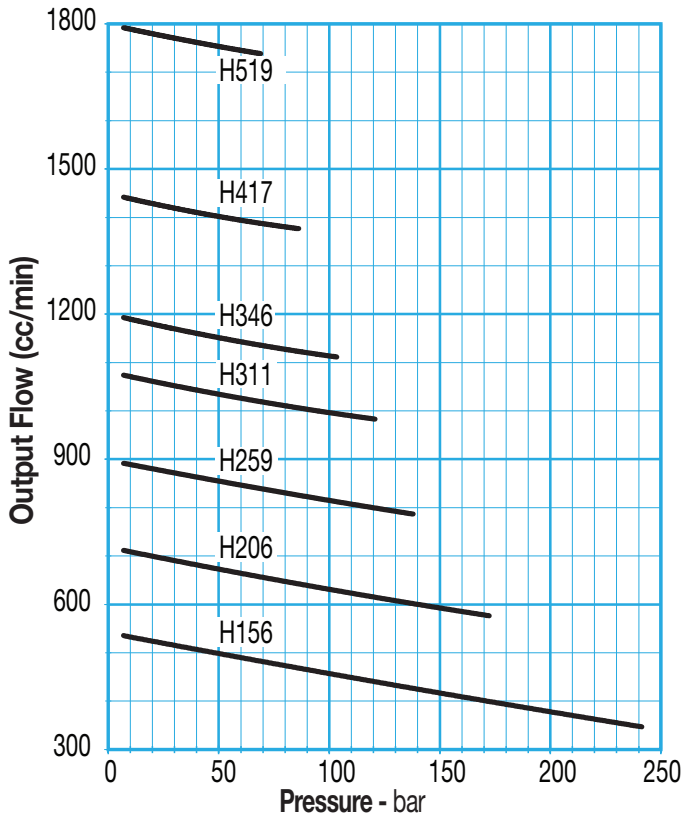

115 VAC Motor Current 60 Hz

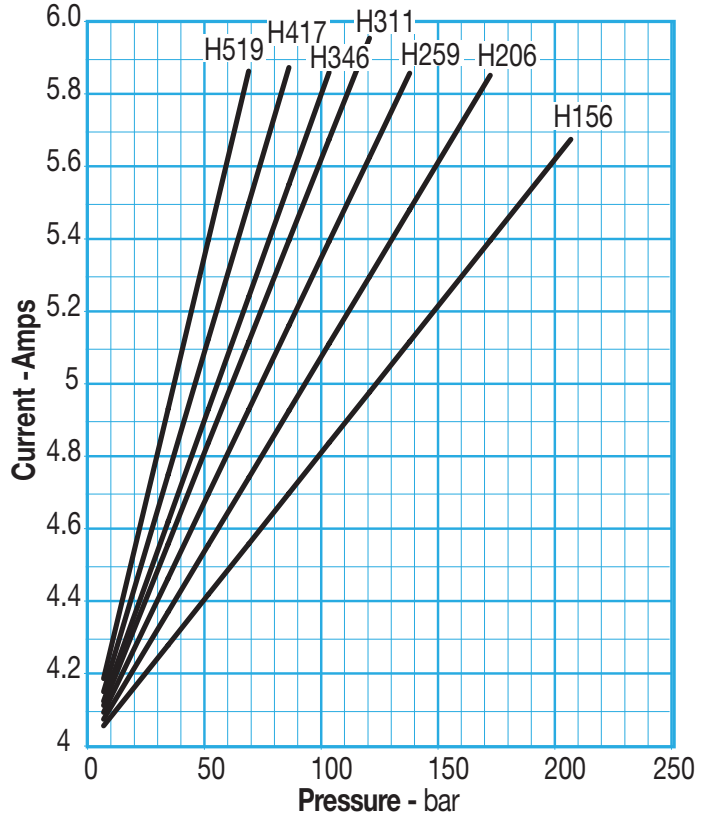

NOTES:

The 115 VAC performance shown is at 60 Hz.
 At 230 VAC the current draw will be approximately 1/2 of that shown.
 At 50 Hz, the flow will be about 5/6 of that shown and the current will be about 25% higher than the 60 Hz values.
 Performance data shown is for reference only.



Dimensions

Miniature Piston Pump

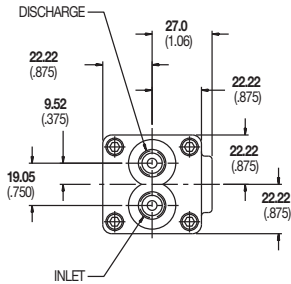

PORT SINGLE DIRECTION ROTATION (OPTIONAL INLET)
PORT BI-DIRECTIONAL ROTATION (REQUIRED CASE DRAIN)

ALL PORTS ARE #4 SAE 7/16-20 UNF-2B
PUMP SHOWN IS CLOCKWISE ROTATION
56C ADAPTER SUPPLIED WITH COUPLING AND MOUNTING SCREWS

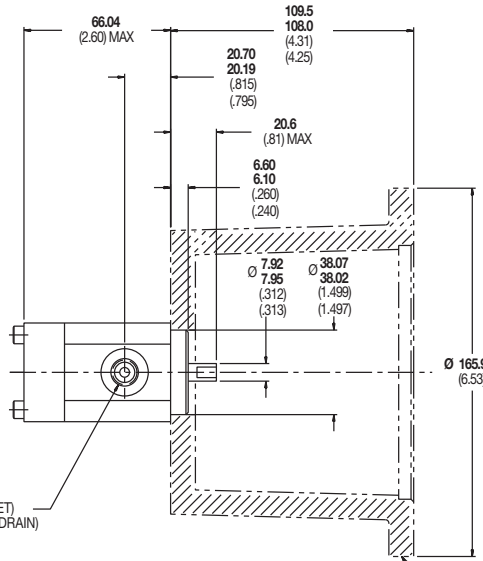

Basic Pump

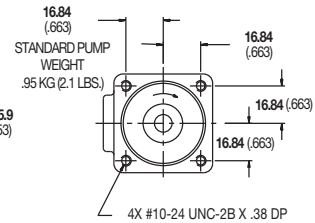

OPTIONAL 56C ADAPTER (REQUIRES LONG PUMP SHA)

Standard 1/3 HP DC Permanent Magnet Motor with Pump

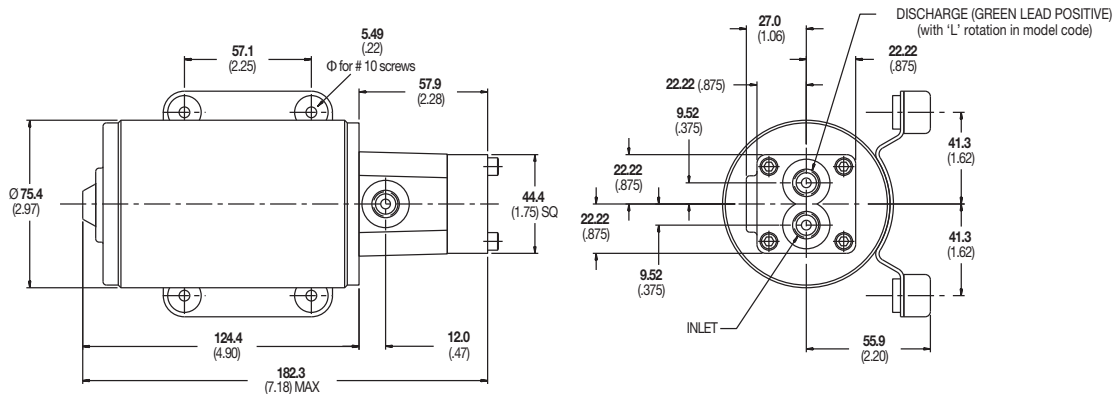

WEIGHT OF STANDARD MOTOR IS 1.82 KG (4 LBS)

THIRD ANGLE
PROJECTION

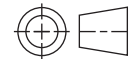

Standard 1/3 HP AC Motor with Pump

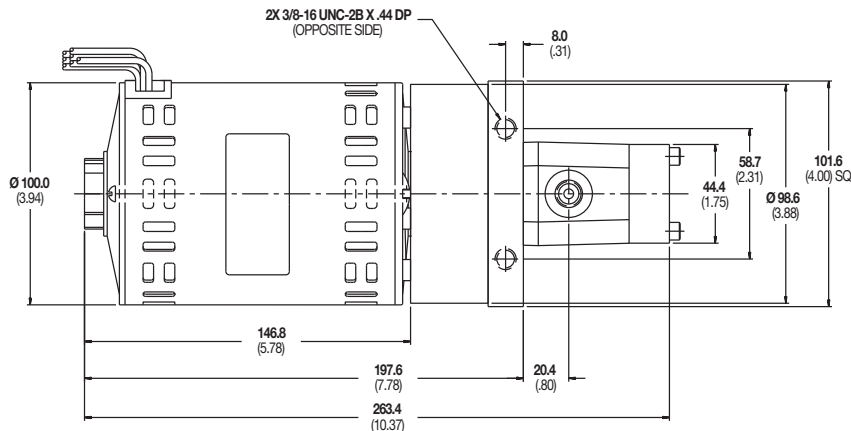

Note: All dimensions in mm (inches).

Tandem Miniature Piston Pump

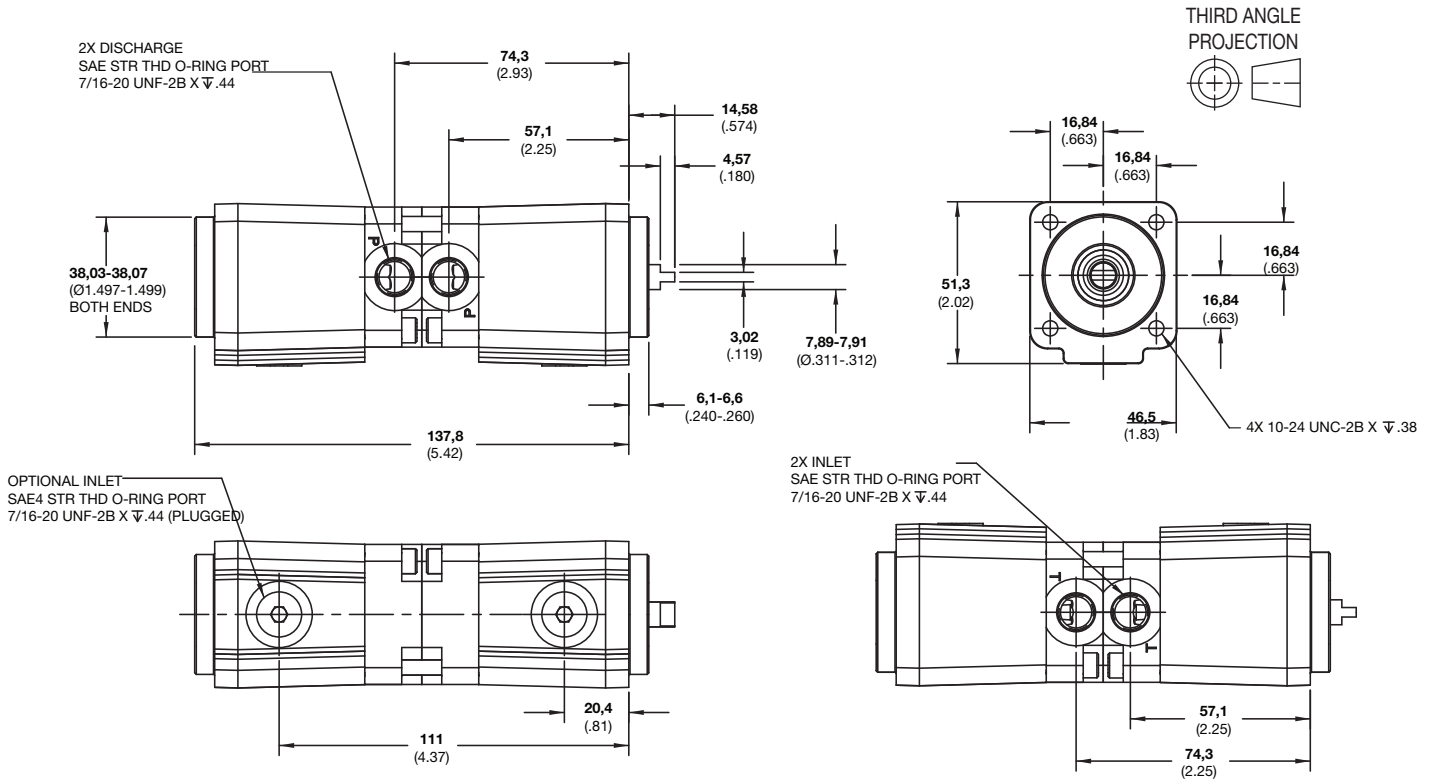

Note: tandem pumps are not completely isolated from each other.

Note: All dimensions in mm (inches)

Cartridge Pump Ordering Code

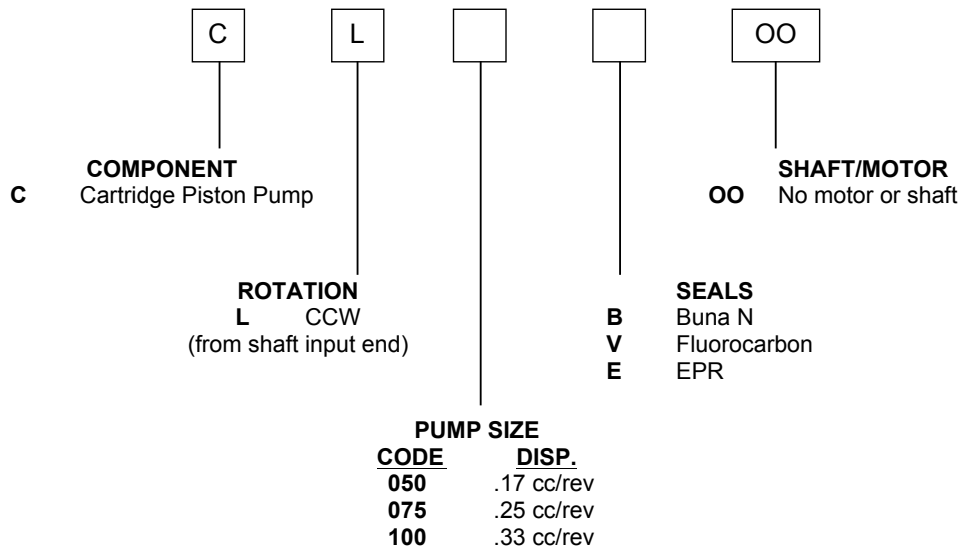

Cartridge Piston Pump Performance

Cartridge pump flow at 23°C on DOT 3 brake fluid

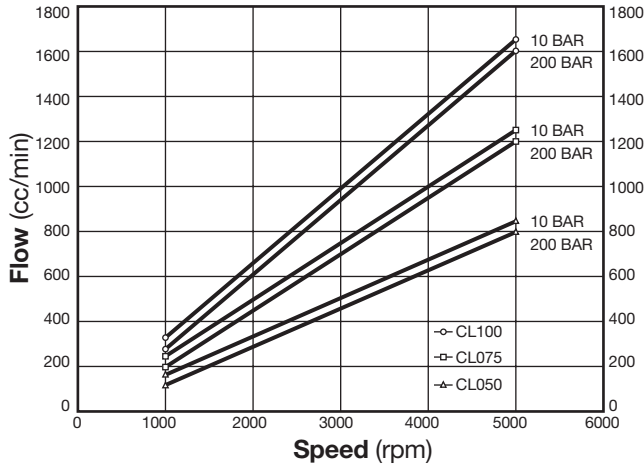

Cartridge pump input torque at 23°C on DOT 3 brake fluid

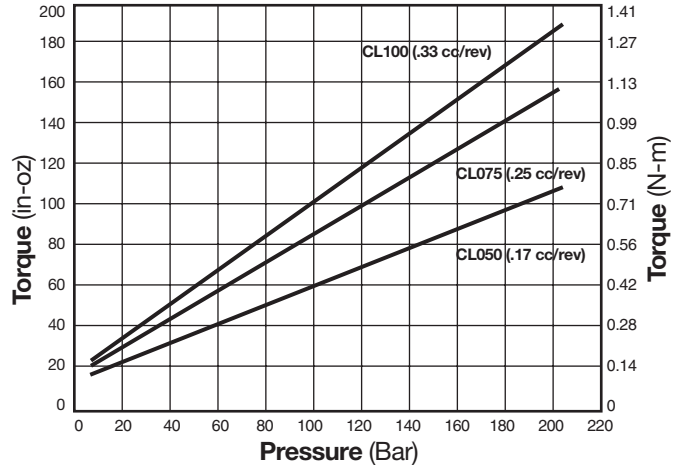

Specifications

- Displacements:** .1 cc/rev. (.006 in³/rev.) to .33 cc/rev. (.020 in³/rev.)
- Speeds:** Up to 5000 rpm maximum
- Pressures:** 207 bar (3000 psi) maximum continuous
276 bar (4000 psi) maximum intermittent
- Temperature Ranges:** Up to 120°C (250°F)
- Seals Available:** Variety
- Weight:** .19 kg (.42 lbs)
- Fluids Compatibility:** Variety, not water-based

*Specifications subject to change without notice.
 Performance data is for reference only.*

This cartridge piston pump continues Oildyne's tradition of producing innovative products which can be customized to specific industries. Please call us to discuss how this cartridge pump can be used in your unique application. **Detailed cavity and motor interface dimensions are available on request. Ask for Oildyne drawing 500059**

Cartridge Pump Dimensions

(with sample manifold requirements)

All dimensions in mm (inches)

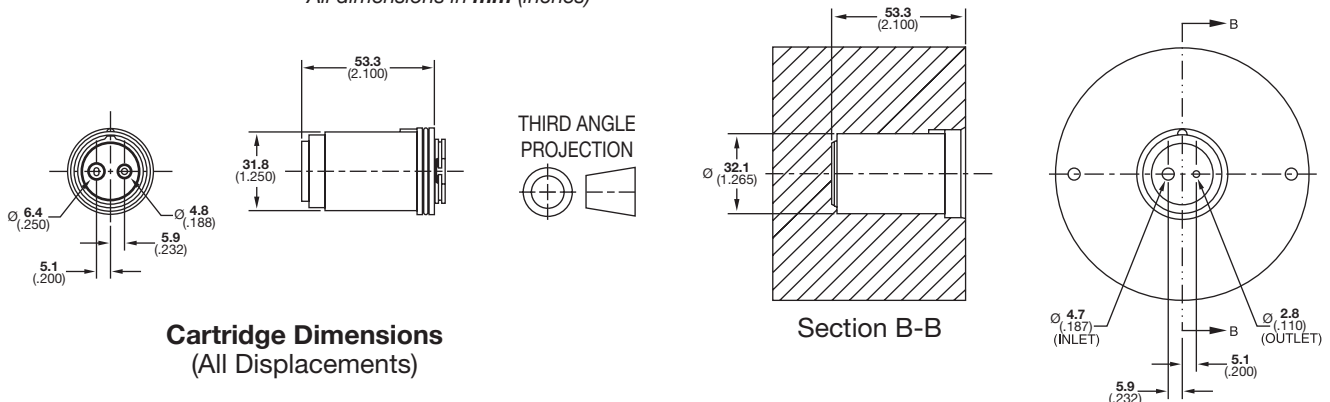

Sample Manifold Requirements

PARKER-HANNIFIN CORPORATION
OFFER OF SALE

The goods, services or work (referred to as the "Products") offered by **Parker-Hannifin Corporation**, its subsidiaries, groups, divisions, and authorized distributors ("Seller") are offered for sale at prices indicated in the offer, or as may be established by Seller. The offer to sell the Products and acceptance of Seller's offer by any customer ("Buyer") is contingent upon, and will be governed by all of the terms and conditions contained in this Offer of Sale. Buyer's order for any Products specified in Buyer's purchase document or Seller's offer, proposal or quote ("Quote") attached to the purchase order, when communicated to Seller verbally, or in writing, shall constitute acceptance of this offer.

1. Terms and Conditions. Seller's willingness to offer Products for sale or accept an order for Products is subject to the terms and conditions contained in this Offer of Sale or any newer version of the same, published by Seller electronically at www.parker.com/saleterms/. Seller objects to any contrary or additional terms or conditions of Buyer's order or any other document or other communication issued by Buyer.

2. Price; Payment. Prices stated on Seller's Quote are valid for thirty (30) days, except as explicitly otherwise stated therein, and do not include any sales, use, or other taxes or duties unless specifically stated. Seller reserves the right to modify prices to adjust for any raw material price fluctuations. Unless otherwise specified by Seller, all prices are F.C.A. Seller's facility (INCOTERMS 2010). Payment is subject to credit approval and payment for all purchases is due thirty (30) days from the date of invoice (or such date as may be specified by Seller's Credit Department). Unpaid invoices beyond the specified payment date incur interest at the rate of 1.5% per month or the maximum allowable rate under applicable law.

3. Shipment; Delivery; Title and Risk of Loss. All delivery dates are approximate. Seller is not responsible for damages resulting from any delay. Regardless of the manner of shipment, delivery occurs and title and risk of loss or damage pass to Buyer, upon placement of the Products with the shipment carrier at Seller's facility. Unless otherwise stated, Seller may exercise its judgment in choosing the carrier and means of delivery. No deferment of shipment at Buyers' request beyond the respective dates indicated will be made except on terms that will indemnify, defend and hold Seller harmless against all loss and additional expense. Buyer shall be responsible for any additional shipping charges incurred by Seller due to Buyer's acts or omissions.

4. Warranty. Seller warrants that the Products sold hereunder shall be free from defects in material or workmanship for a period of twelve (12) months from the date of delivery or 2,000 hours of normal use, whichever occurs first. All prices are based upon the exclusive limited warranty stated above, and upon the following disclaimer: **DISCLAIMER OF WARRANTY: THIS WARRANTY IS THE SOLE AND ENTIRE WARRANTY PERTAINING TO PRODUCTS PROVIDED. SELLER DISCLAIMS ALL OTHER WARRANTIES, EXPRESS AND IMPLIED, INCLUDING DESIGN, MERCHANTABILITY AND FITNESS FOR A PARTICULAR PURPOSE.**

5. Claims; Commencement of Actions. Buyer shall promptly inspect all Products upon receipt. No claims for shortages will be allowed unless reported to the Seller within ten (10) days of delivery. No other claims against Seller will be allowed unless asserted in writing within thirty (30) days after delivery. Buyer shall notify Seller of any alleged breach of warranty within thirty (30) days after the date the defect is or should have been discovered by Buyer. Any claim or action against Seller based upon breach of contract or any other theory, including tort, negligence, or otherwise must be commenced within twelve (12) months from the date of the alleged breach or other alleged event, without regard to the date of discovery.

6. LIMITATION OF LIABILITY. IN THE EVENT OF A BREACH OF WARRANTY, SELLER WILL, AT ITS OPTION, REPAIR OR REPLACE A DEFECTIVE PRODUCT, OR REFUND THE PURCHASE PRICE WITHIN A REASONABLE PERIOD OF TIME. **IN NO EVENT IS SELLER LIABLE FOR ANY SPECIAL, INDIRECT, INCIDENTAL OR CONSEQUENTIAL DAMAGES ARISING OUT OF, OR AS THE RESULT OF, THE SALE, DELIVERY, NON-DELIVERY, SERVICING, USE OR LOSS OF USE OF THE PRODUCTS OR ANY PART THEREOF, OR FOR ANY CHARGES OR EXPENSES OF ANY NATURE INCURRED WITHOUT SELLER'S WRITTEN CONSENT, WHETHER BASED IN CONTRACT, TORT OR OTHER LEGAL THEORY. IN NO EVENT SHALL SELLER'S LIABILITY UNDER ANY CLAIM MADE BY BUYER EXCEED THE PURCHASE PRICE OF THE PRODUCTS.**

7. User Responsibility. The user, through its own analysis and testing, is solely responsible for making the final selection of the system and Product and assuring that all performance, endurance, maintenance, safety and warning requirements of the application are met. The user must analyze all aspects of the application and follow applicable industry standards and Product information. If Seller provides Product or system options based upon data or specifications provided by the user, the user is responsible for determining that such data and specifications are suitable and sufficient for all applications and reasonably foreseeable uses of the Products or systems.

8. Loss to Buyer's Property. Any designs, tools, patterns, materials, drawings, confidential information or equipment furnished by Buyer or any other items which become Buyer's property, will be considered obsolete and may be destroyed by Seller after two (2) consecutive years have elapsed without Buyer ordering the items manufactured using such property. Seller shall not be responsible for any loss or damage to such property while it is in Seller's possession or control.

9. Special Tooling. A tooling charge may be imposed for any special tooling, including without limitation, dies, fixtures, molds and patterns, acquired to manufacture Products. Such special tooling shall be and remain Seller's property notwithstanding payment of any charges by Buyer. In no event will Buyer acquire any interest in apparatus belonging to Seller which is utilized in the manufacture of the Products, even if such apparatus has been specially converted or adapted for such manufacture and notwithstanding any charges paid by Buyer. Unless otherwise agreed, Seller has the right to alter, discard or otherwise dispose of any special tooling or other property in its sole discretion at any time.

10. Buyer's Obligation; Rights of Seller. To secure payment of all sums due or otherwise, Seller retains a security interest in all Products delivered to Buyer and this agreement is deemed to be a Security Agreement under the Uniform Commercial Code. Buyer authorizes Seller as its attorney to execute and file on Buyer's behalf all documents Seller deems necessary to perfect its security interest.

11. Improper Use and Indemnity. Buyer shall indemnify, defend, and hold Seller harmless from any losses, claims, liabilities, damages, lawsuits, judgments and costs (including attorney fees and defense costs), whether for personal injury, property damage, patent, trademark or copyright infringement or any other claim, brought by or incurred by Buyer, Buyer's employees, or any other person, arising out of: (a) improper selection, application, design, specification or other misuse of Products purchased by Buyer from Seller; (b) any act or omission, negligent or otherwise, of Buyer; (c) Seller's use of patterns, plans, drawings, or specifications furnished by Buyer to manufacture Products; or (d) Buyer's failure to comply with these terms and conditions. Seller shall not indemnify Buyer under any circumstance except as otherwise provided.

12. Cancellations and Changes. Buyer may not cancel or modify or cancel any order for any reason, except with Seller's written consent and upon terms that will indemnify, defend and hold Seller harmless against all direct, incidental and consequential loss or damage. Seller may change Product features, specifications, designs and availability.

13. Limitation on Assignment. Buyer may not assign its rights or obligations under this agreement without the prior written consent of Seller.

14. Force Majeure. Seller does not assume the risk and is not liable for delay or failure to perform any of Seller's obligations by reason of events or circumstances beyond its reasonable control (hereinafter "Events of Force Majeure"). Events of Force Majeure shall include without limitation: accidents, strikes or labor disputes, acts of any government or government agency, acts of nature, delays or failures in delivery from carriers or suppliers, shortages of materials, or any other cause beyond Seller's reasonable control.

15. Waiver and Severability. Failure to enforce any provision of this agreement will not invalidate that provision; nor will any such failure prejudice Seller's right to enforce that provision in the future. Invalidation of any provision of this agreement by legislation or other rule of law shall not invalidate any other provision herein. The remaining provisions of this agreement will remain in full force and effect.

16. Termination. Seller may terminate this agreement for any reason and at any time by giving Buyer thirty (30) days prior written notice. Seller may immediately terminate this agreement, in writing, if Buyer: (a) breaches any provision of this agreement (b) appoints a trustee, receiver or custodian for all or any part of Buyer's property (c) files a petition for relief in bankruptcy on its own behalf, or one if filed by a third party (d) makes an assignment for the benefit of creditors; or (e) dissolves its business or liquidates all or a majority of its assets.

17. Governing Law. This agreement and the sale and delivery of all Products are deemed to have taken place in, and shall be governed and construed in accordance with, the laws of the State of Ohio, as applicable to contracts executed and wholly performed therein and without regard to conflicts of laws principles. Buyer irrevocably agrees and consents to the exclusive jurisdiction and venue of the courts of Cuyahoga County, Ohio with respect to any dispute, controversy or claim arising out of or relating to this agreement.

18. Indemnity for Infringement of Intellectual Property Rights. Seller is not liable for infringement of any patents, trademarks, copyrights, trade dress, trade secrets or similar rights except as provided in this Section. Seller will defend and indemnify Buyer against allegations of infringement of U.S. patents, U.S. trademarks, copyrights, trade dress and trade secrets ("Intellectual Property Rights"). Seller will defend at its expense and will pay the cost of any settlement or damages awarded in an action brought against Buyer based on an allegation that a Product sold pursuant to this agreement infringes the Intellectual Property Rights of a third party. Seller's obligation to defend and indemnify Buyer is contingent on Buyer notifying Seller within ten (10) days after Buyer becomes aware of such allegations of infringement, and Seller having sole control over the defense of any allegations or actions including all negotiations for settlement or compromise. If a Product is subject to a claim that it infringes the Intellectual Property Rights of a third party, Seller may, at its sole expense and option, procure for Buyer the right to continue using the Product, replace or modify the Product so as to make it noninfringing, or offer to accept return of the Product and refund the purchase price less a reasonable allowance for depreciation. Notwithstanding the foregoing, Seller is not liable for claims of infringement based on information provided by Buyer, or directed to Products delivered hereunder for which the designs are specified in whole or part by Buyer, or infringements resulting from the modification, combination or use in a system of any Product sold hereunder. The foregoing provisions of this Section constitute Seller's sole and exclusive liability and Buyer's sole and exclusive remedy for infringement of Intellectual Property Rights.

19. Entire Agreement. This agreement contains the entire agreement between the Buyer and Seller and constitutes the final, complete and exclusive expression of the terms of sale. All prior or contemporaneous written or oral agreements or negotiations with respect to the subject matter are herein merged. The terms contained herein may not be modified unless in writing and signed by an authorized representative of Seller.

20. Compliance with Laws. Buyer agrees to comply with all applicable laws, regulations, and industry and professional standards of care, including those of the United Kingdom the United States of America, and the country or countries in which Buyer may operate, including without limitation the U. K. Bribery Act, the U.S. Foreign Corrupt Practices Act ("FCPA"), the U.S. Anti-Kickback Act ("Anti-Kickback Act") and the U.S. Food Drug and Cosmetic Act ("FDCA"), each as currently amended, and the rules and regulations promulgated by the U.S. Food and Drug Administration ("FDA"), and agrees to indemnify and hold harmless Seller from the consequences of any violation of such provisions by Buyer, its employees or agents. Buyer acknowledges that it is familiar with the provisions of the U. K. Bribery Act, the FCPA, the FDA, and the Anti-Kickback Act, and certifies that Buyer will adhere to the requirements thereof. In particular, Buyer represents and agrees that Buyer will not make any payment or give anything of value, directly or indirectly to any governmental official, any foreign political party or official thereof, any candidate for foreign political office, or any commercial entity or person, for the purpose of influencing such person to purchase Products or otherwise benefit the business of Seller.