

13 Displacements 13 Schluckvolumen 13 Cylindrée 13 Despazamientos	(8.6 to 58.5 in ³ /rev) 140 . . . 958 cm ³ /rev	
Maximum Pressure Eingangsdruck Pression entrée Presion Maxima	Cont. (3000 psid) . . . 207 bar	Int. (4000 psid) . . . 276 bar
Maximum Oil Flow Schluckstrom Débit d'huile Caudal Maximo de Aceite	(30 gpm) . . . 114 lpm	
Maximum Speed Drehzahl Vitesse de rotation Velocidad Maxima	(660 rpm) 660 rpm	
Maximum Torque MaxDrehmoment Couple Torque Maximo	Cont. (9,239 lb in) 1044 Nm	Int. (12,636 lb in) 1428 Nm
Maximum Side Load at Key Seitenlast Charges latérales Carga Maxima Lateral	(3597 lb) . . . 16000 N	

A Mechanical Brake Motor for Tough Applications

Parker's DG Series brake motors consists of a mechanical drum brake mounted integrally to our rugged TG Series LSHT hydraulic motor. The compact size, reliable holding capacity and ease of installation make this motor with parking brake the ideal choice for the propulsion systems on many turf, agricultural and other vehicles.

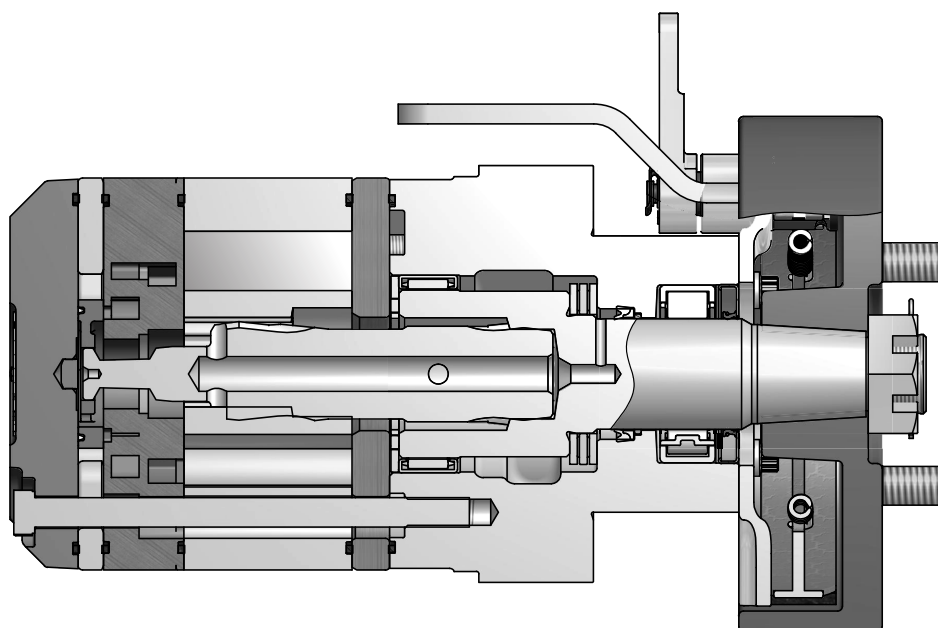

The brake is available with either vertical or horizontally applied levers. The vertical style has fixed brake pads, while the horizontal version has floating brake pads that can be adjusted as required over the life of the brake. Both versions are for static applications only.







DG Series **XXXX** Displacement / Schluckvolumen / Cylindrée / Desplazamiento
XS Mounting/Ports / Gehäuse/Anschluß / Carter/Plan de raccordement / Montaje/Lumbreras
X Drum Type / Trommelbremse / Tipo de tambor / Genre de tambour
X Shaft / Welle / Arbre / Eje
0 Rotation / Drehrichtung / Direction de rotation / Rotacion
XXXX Options / Opciones

Code	cm ³ /tr cm ³ /giro cm ³ /U	in ³ /rev
0140	141	8.6
0170	169	10.3
0195	195	11.9
0240	238	14.5
0280	280	17.1
0310	310	18.9
0335	337	20.6
0360	360	22.2
0405	405	24.7
0475	477	29.1
0530	528	32.3
0625	623	38.0
0785	786	48.0
0960	959	58.5

Code	Drum Type
A	 4 Bolt
B	 5 Bolt

Code	Front Port Rotation
0	Standard 
1	Reverse Timed Manifold 

Code	Shaft
8	1 1/4" Tapered

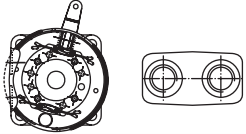
Code	Mounting/Ports - Vertical Lever
AS	Wheel Mt. w/Brake Lever @ 105° / 7/8-14 SAE 
BS	Wheel Mt. w/Brake Lever @ 165° / 7/8-14 SAE
CS	Wheel Mt. w/Brake Lever @ 195° / 7/8-14 SAE
DS	Wheel Mt. w/Brake Lever @ 255° / 7/8-14 SAE
ES	Wheel Mt. w/Brake Lever @ 285° / 7/8-14 SAE
FS	Wheel Mt. w/Brake Lever @ 345° / 7/8-14 SAE
GS	Wheel Mt. w/Brake Lever @ 15° / 7/8-14 SAE
HS	Wheel Mt. w/Brake Lever @ 75° / 7/8-14 SAE

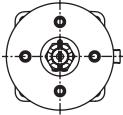
Code	Mounting/Ports - Horizontal Lever
VS	Wheel Mt. w/Brake Lever @ 90° / 7/8-14 SAE 
WS	Wheel Mt. w/Brake Lever @ 180° / 7/8-14 SAE
US	Wheel Mt. w/Brake Lever @ 270° / 7/8-14 SAE

Code	Options
AAAA	Standard, Black Paint
AAAB	Standard, No Paint
AAAC	Double Paint
AAAF	Castle Nut, Black Paint
AABP	Castle Nut, No Paint
AAAG	Fluorocarbon Seals, Black Paint
AAAH	Fluorocarbon Seals, No Paint
AAAJ	High Temperature Commutator Seals, Black Paint
AAFG	High Temperature Commutator Seals, No Paint
AAFW	Fluorocarbon seals, High Temperature Commutator Seals, Black paint
AAFA	Fluorocarbon seals, High Temperature Commutator Seals, No paint
AANG	Fluorocarbon seals, High Temperature Commutator Seals, Castle Nut, Black paint
AADD	Fluorocarbon seals, High Temperature Commutator Seals, Castle Nut, No paint

For other available options, see pages 237-238.

Vertical Lever

Holding capacity is 497 Nm (4,400 in lbs) with 68 Nm (600 in lbs) of input torque at lever pivot. Brake capacities are typical for non-burnished brake shoe. OEM testing required to verify actual field conditions.

Das maximale Bremsmoment von 497 Nm (4400 in lbs) wird erreicht durch Betätigung des Bremshebels mit 68 Nm (600 in lbs). Genannte Einsatzdaten beziehen sich auf Neuprodukte. Die Eignung der Geräte ist vom Anwender für den jeweiligen Einsatz individuell zu prüfen.

La puissance de maintien est de 497 Nm (4400 pouces-livres) avec couple d'entrée au pivot du levier de 68 Nm (600 pouces-livres). Les puissances de freinage sont typiques pour des sabots de frein non brunis. Les essais imposés par le constructeur d'origine exigent la vérification des conditions réelles sur place.

Capacidad de retención de 497 N-m (4.400 libras-pulgada) con 69 N-m (600 libras-pulgada) de torque de entrada en el brazo de articulación. Los valores de capacidad de frenado son típicos para zapatas de freno no bruñidas. Para fabricantes de equipos originales se deben efectuar pruebas bajo condiciones reales de funcionamiento.

Horizontal Lever

Brake Torque and Travel of 3.72 inch Horizontal Lever

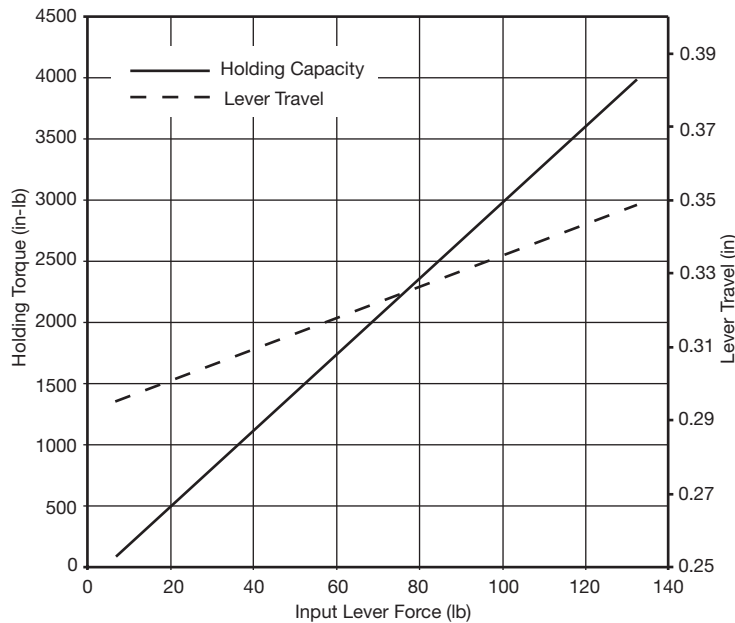

Wheel Mount/Radnabengehause
Monture à roue/ Montaje de rueda

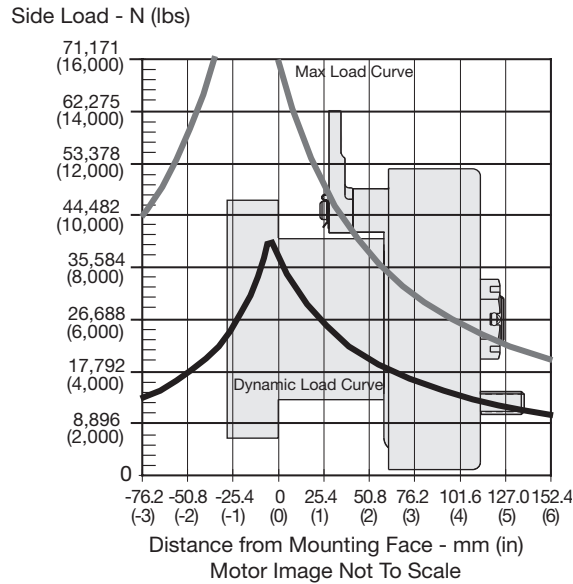

The dynamic side load curve is based on uni-directional steady state loads for L_{10} bearing life at 3×10^6 revolutions. Die zulässige auslegbare radiale Wellenbelastungskurve ist unter ruhenden, einseitig statisch gerichteten Lastverhältnissen auf eine L_{10} Lebensdauer mit 3×10^6 Umdrehungen kalkuliert. La courbe de charge latérale permise se base sur des charges unidirectionnelles en régime permanent pour le roulement L_{10} à 3×10^6 révolutions. La curva de valores admisibles de carga lateral está basada en cargas constantes para cojinetes L_{10} a 3×10^6 revoluciones.

The maximum load curve is defined by bearing static load capacity. This curve should not be exceeded at any time including shock loads. Die maximale radiale Wellenbelastungskurve ist definiert als maximale statische Last ohne Drehzahl. Sie gilt als Grenze und sollte keinesfalls überschritten werden. La courbe de charge maximale est définie par la capacité de charge statique portante. Cette courbe ne devrait être dépassée en aucun moment y compris pour les charges par à-coups. La curva de carga máxima queda definida por la capacidad de carga estática del cojinete. No se deben superar los valores de esta curva, ni siquiera con cargas provisorias de impacto.

Equation to Calculate the Expected Radial Bearing Life
Gleichung zur Ermittlung der Lagerlebensdauer

Equation to calculate the dynamic bearing life for a given load:
Bestimmung der erlaubten radialen Wellenbelastung mit vorgegebener Last

Use F_a , F_b and S in equation to determine hours of L_{10} bearing life.
Die Lebensdauer in Stunden ergibt sich durch einsetzen von F_a , F_b , und S in die nachstehende Formel.

$$L = \frac{3 \times 10^6}{60 \times S} \left\{ \frac{F_a}{F_b} \right\}^{3.33}$$

Where / Mit:

- S = Shaft Speed RPM / Abtriebswellendrehzahl in min^{-1}
- L = Life In Hours / Lebensdauer in Stunden
- F_a = Dynamic side load defined by above curve at a distance from mounting flange. / Erlaubte radiale Wellenbelastung als Funktion der Laenge
- F_b = Application side load. / Anwendungsseitige Wellenbelastung

Note: Calculations are based on L_{10} bearing life per ISO 281.
Auslegung basiert auf einer L_{10} Lebensdauer nach ISO 281

Code: AS - Vertical Lever

Wheel Mount w/Brake Lever / 7/8-14 SAE O-Ring

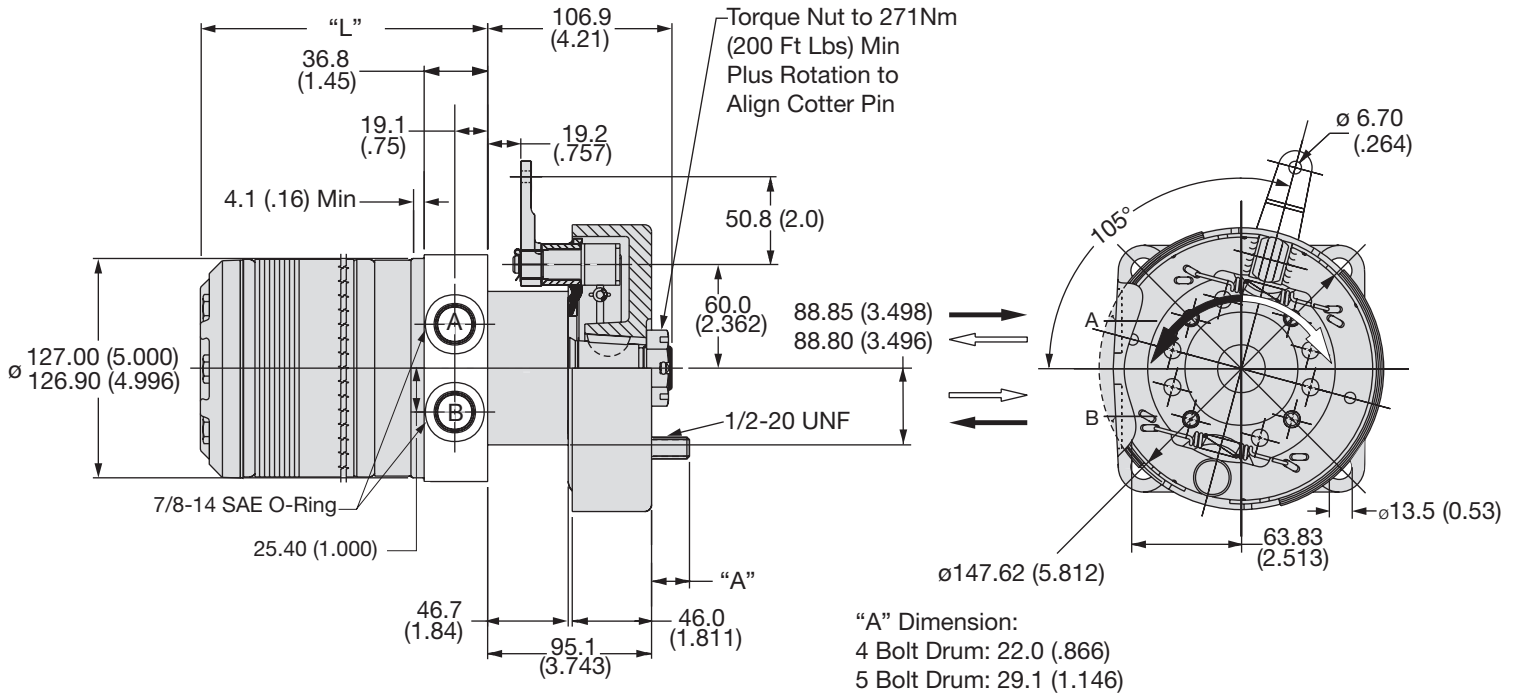

Note:

1. Brake Acuation Lever can be positioned in 12.00° increments from that shown.
 Bremshebel ist kreisförmig in Sgmenten von 12.00 ° positionierbar.
 Le levier de commande du frein peut être positionné à des échelons d'accroissement de 12,00° de ce qui est montré.
 El brazo de actuación del freno se puede colocar en avances de 12,00 grados con respecto a la posición mostrada.
2. Brake Acuation Lever is shipped unattached, secured with wire or tiewrap to assembly.
 Hebel ist anbei. Endmontage erforderlich.
 Le levier de commande du frein est expédié sous forme détachée; il est attaché à l'ensemble avec du fil ou du ruban.
 El brazo de actuación del freno se suministra suelto, sin conexión, sólo atado provisoriamente al mecanismo.

Code AS	disp.	0140	0170	0195	0240	0280	0310	0335	0405	0475	0530	0625	0785	0960
Weight/Gewicht	kg	14.6	14.8	15.1	15.5	15.9	16.1	16.3	16.9	17.5	18.3	19.0	20.5	22.2
Poids/Peso	(lb)	(41.3)	(41.8)	(42.4)	(43.2)	(44.1)	(44.6)	(44.9)	(46.3)	(47.7)	(49.4)	(50.9)	(54.4)	(58.1)
Length	"L" mm	150.4	153.4	156.7	161.3	166.1	169.7	172.5	179.8	188.5	194.8	204.2	223.3	242.3
	"L" (in)	(5.92)	(6.04)	(6.17)	(6.35)	(6.54)	(6.68)	(6.79)	(7.08)	(7.42)	(7.67)	(8.04)	(8.79)	(9.54)

For performance data curves, see TG section.

English equivalents for metric specifications are shown in ().

013 DG Brake.indd, js



Code: US - Horizontal Lever

Wheel Mount w/Brake Lever / 7/8-14 SAE O-Ring

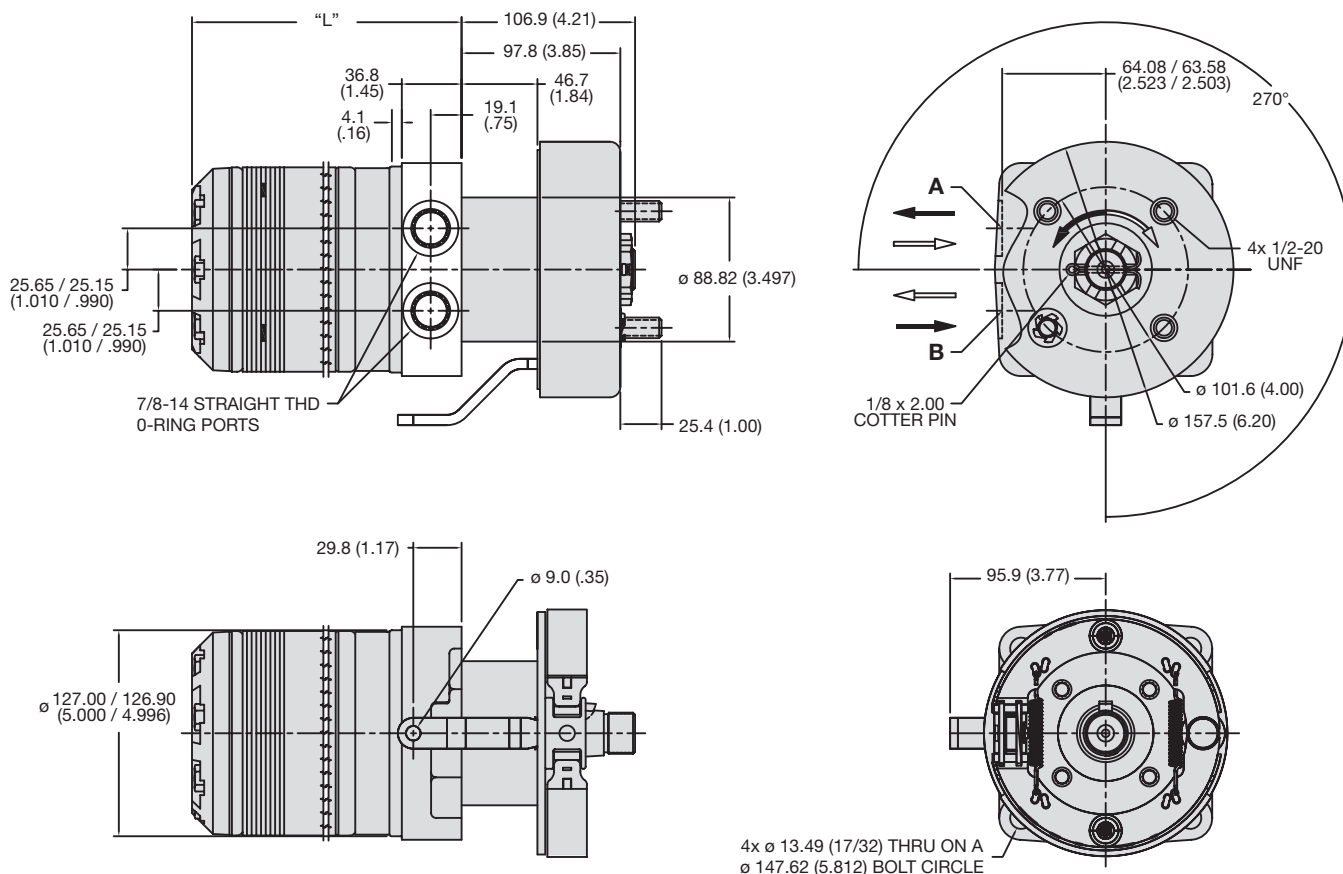

Note:

Brake Acuation Lever can be positioned in 90° increments from that shown.

Bremshebel ist kreisförmig in Sgmenten von 90° positionierbar.

Le levier de commande du frein peut être positionné à des échelons d'accroissement de 90° de ce qui est montré.

El brazo de actuación del freno se puede colocar en avances de 90° grados con respecto a la posición mostrada.

Code US	disp.	0140	0170	0195	0240	0280	0310	0335	0405	0475	0530	0625	0785	0960
Weight/Gewicht	kg	14.6	14.8	15.1	15.5	15.9	16.1	16.3	16.9	17.5	18.3	19.0	20.5	22.2
Poids/Peso	(lb)	(41.3)	(41.8)	(42.4)	(43.2)	(44.1)	(44.6)	(44.9)	(46.3)	(47.7)	(49.4)	(50.9)	(54.4)	(58.1)
Length	"L" mm	150.4	153.4	156.7	161.3	166.1	169.7	172.5	179.8	188.5	195.6	204.2	223.3	242.3
	"L" (in)	(5.92)	(6.04)	(6.17)	(6.35)	(6.54)	(6.68)	(6.79)	(7.08)	(7.42)	(7.67)	(8.04)	(8.79)	(9.54)

For performance data curves, see TG section.

English equivalents for metric specifications are shown in ().

013 DG Brake.indd, js

Drum Type/Trommelbremse/
Tipo de tambor/
Genre de Tambour

Code: A

4 Bolt

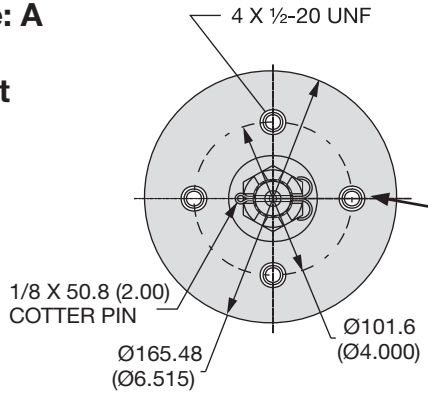

Code: B

5 Bolt

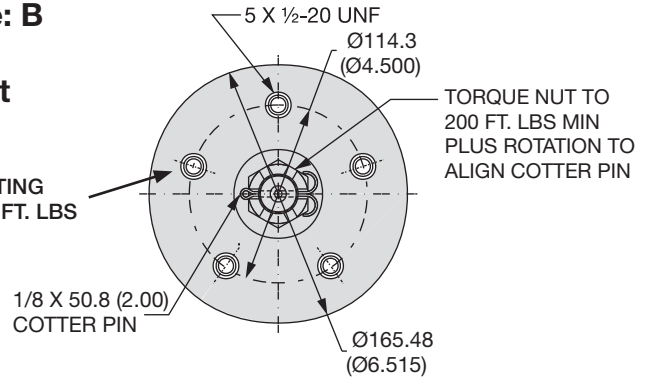

Shafts / Abtriebswellen
Arbre / Ejes

Code: 8

1 1/4" Taper

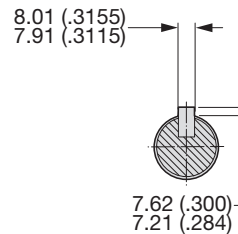
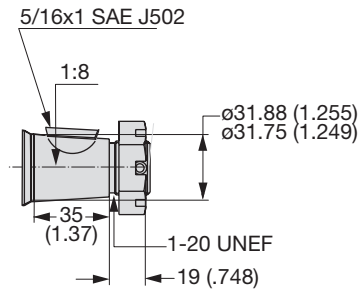
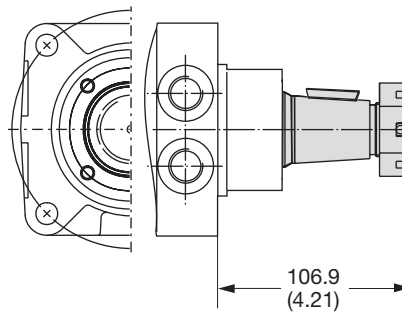

English equivalents for metric specifications are shown in ().

013 DG Brake.indd, js

