



ATLANTIC
Fluid Tech

**SECTION
12**

Flow Dividers
and
Combiners

SECTION 12

FLOW DIVIDERS AND COMBINERS



Hydraulic scheme	Valve description	Valve type	Rated flow (l/min)	Max. pressure (bar)	Installation	Main port size or cavity type	Page
	CFDT-055-BFAR	Spool type, divider and combiner	55	350	Cartridge	SAE-10-4N	12.01.010
	CFDT-160-BFRR	Spool type, divider and combiner	160	350	Cartridge	SAE-16-4N	12.01.020
	MFDT-040-BFTR	Spool type, divider and combiner	40	210	In line	G 3/8"	12.02.030
	MFDT-040-BFTR	Spool type, divider and combiner	40	210	In line	G 1/2"	12.02.030
	MFDT-150-BFLR	Spool type, divider and combiner	150	210	In line	G 1"	12.02.040
	MFDT-150-BFLR	Spool type, divider and combiner	150	210	In line	G 3/4"	12.02.040
	KFDT-055-BFAR	Spool type, divider and combiner	55	210	In line	G 1/4"	12.02.050
	KFDT-055-BFAR	Spool type, divider and combiner	40	210	In line	G 3/8"	12.02.050
	KFDT-055-BFAR	Spool type, divider and combiner	55	210	In line	G 1/2"	12.02.050

FLOW DIVIDER AND COMBINER

CFDT-055-BFRR

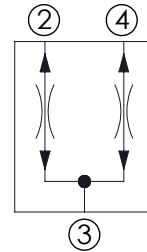
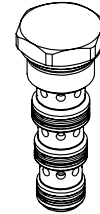
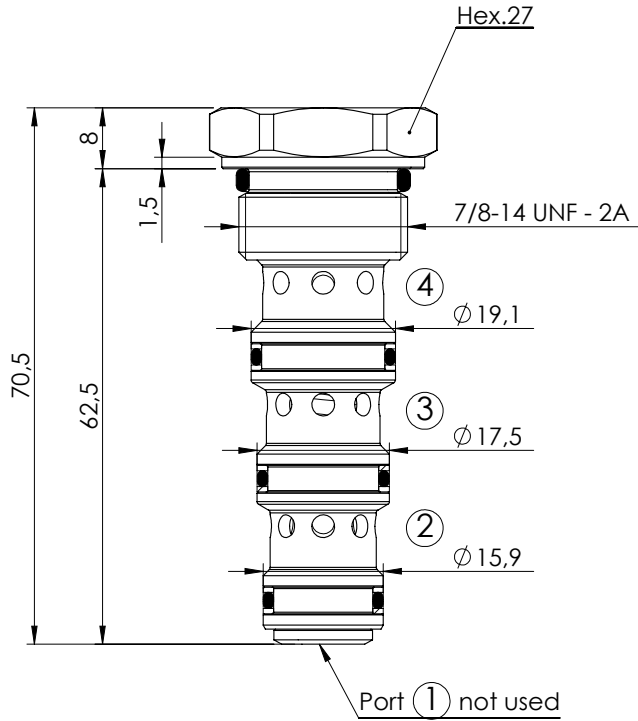

SPECIFICATIONS

Max. operating pressure:	350 bar
Division or combination:	50%-50%
Cavity:	SAE-10-4N -3P
Weight:	0,13 kg
Installation torque:	55 - 62 Nm

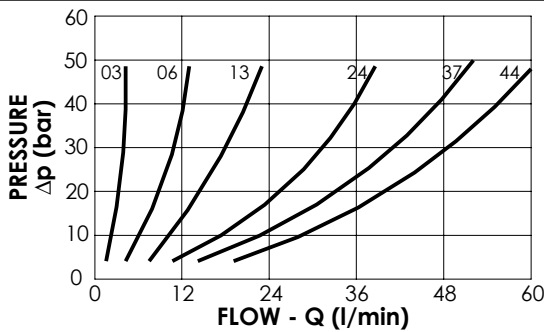

NOTES

Seal kit: **RB700102**

Flow divider accuracy: $\pm 7/8\%$ between 40-100% of max. input flow

- Other dividing ratios available.

ORDERING CODES

Quick code	Description	Inlet range Flow (l/min)	
CF000047	CFDT-055-BFRR-03-S10-N350	1,2-3	
CF000048	CFDT-055-BFRR-06-S10-N350	3-6	
CF000049	CFDT-055-BFRR-13-S10-N350	6-13	
CF000050	CFDT-055-BFRR-24-S10-N350	10-24	
CF000001	CFDT-055-BFRR-37-S10-N350	15-37	
CF000051	CFDT-055-BFRR-44-S10-N350	18-44	

FLOW DIVIDER AND COMBINER

CFDT-160-BFRR

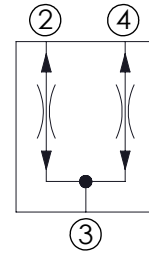
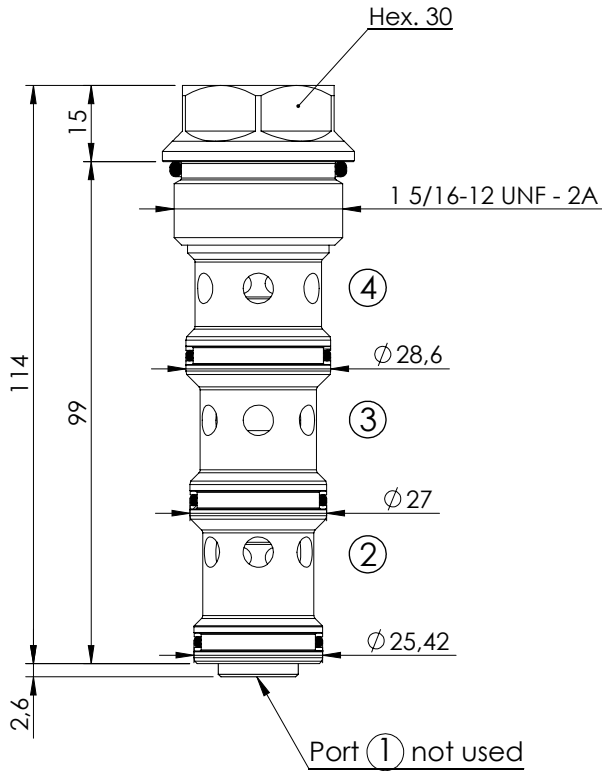

SPECIFICATIONS

Max. operating pressure:	350 bar
Division or combination:	50%-50%
Cavity:	SAE-16-4N
Weight:	0,36 kg
Installation torque:	118 - 132 Nm

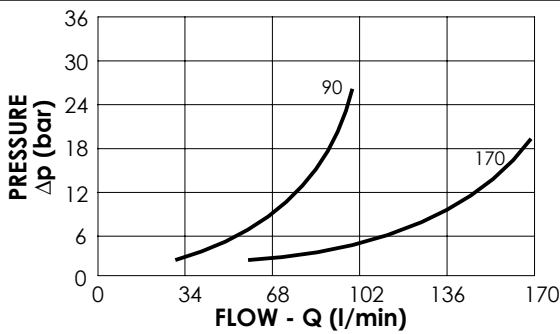

NOTES

- Seal kit: RB700104
- Flow divider accuracy: $\pm 7/8\%$ between 40-100% of max. input flow
- Other dividing ratios available.

ORDERING CODES

Quick code	Description	Inlet range Flow (l/min)	
CF000364	CFDT-160-BFRR-90-S16-N350	30 - 90	
CF000370	CFDT-160-BFRR-170-S16-N350	50 - 170	

FLOW DIVIDER AND COMBINER

MFDT-040-BFTR

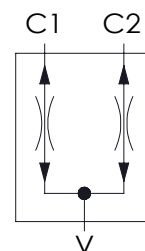
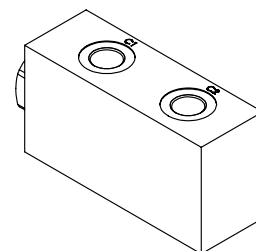
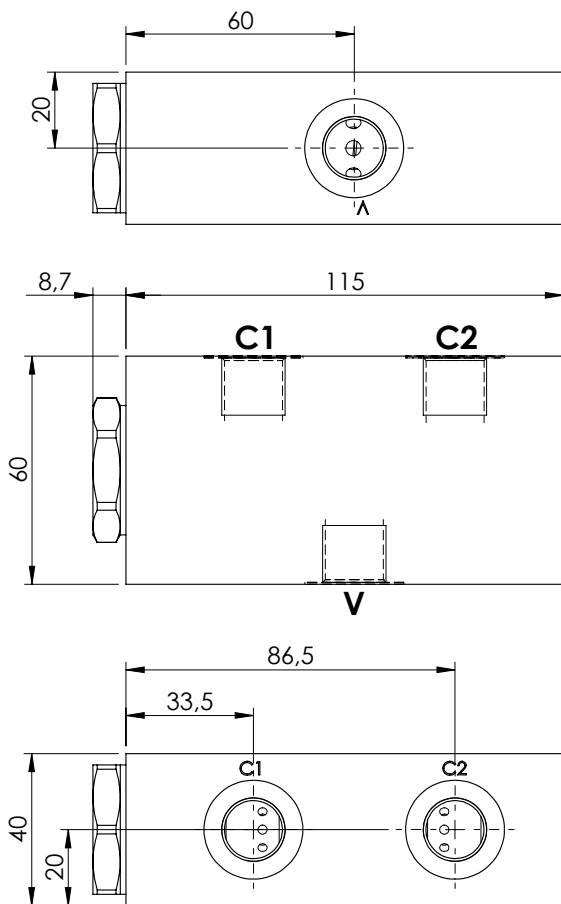

SPECIFICATIONS

Max. operating pressure:	210 bar
Division or combination:	50% - 50%
Manifold:	Aluminium
Weight:	0,88 kg
Cavity:	VP000242

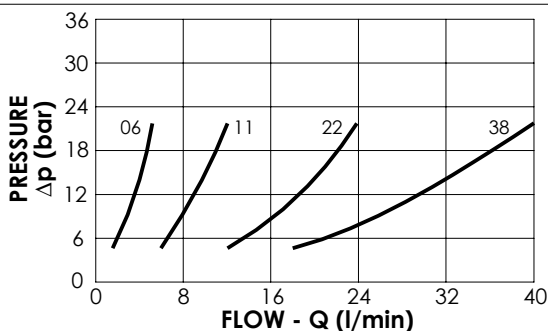

NOTES

Flow divider accuracy: $\pm 4/5\%$ between 40-100% of max. input flow

ORDERING CODES

Quick code	Description	Main ports size	Inlet range Flow (l/min)	
MF000076	MFDT-040-BFTR-06-G38-N210	V:G3/8" ; C1,C2:G 3/8"	2,8 - 5,8	
MF000077	MFDT-040-BFTR-11-G38-N210	V:G3/8" ; C1,C2:G 3/8"	6,5 - 11	
MF000078	MFDT-040-BFTR-22-G38-N210	V:G3/8" ; C1,C2:G 3/8"	13 - 22	
MF000075	MFDT-040-BFTR-38-G38-N210	V:G3/8" ; C1,C2:G 3/8"	25 - 38	
MF000080	MFDT-040-BFTR-06-G12-N210	V:G1/2" ; C1,C2:G 3/8"	2,8 - 5,8	
MF000081	MFDT-040-BFTR-11-G12-N210	V:G1/2" ; C1,C2:G 3/8"	6,5 - 11	
MF000082	MFDT-040-BFTR-22-G12-N210	V:G1/2" ; C1,C2:G 3/8"	13 - 22	
MF000079	MFDT-040-BFTR-38-G12-N210	V:G1/2" ; C1,C2:G 3/8"	25 - 38	

FLOW DIVIDER AND COMBINER

MFDT-150-BFLR

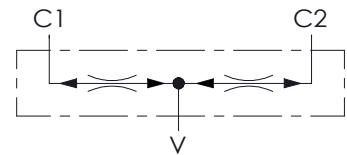
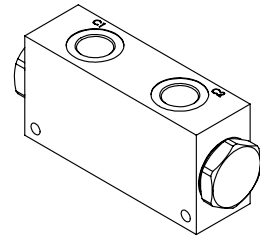
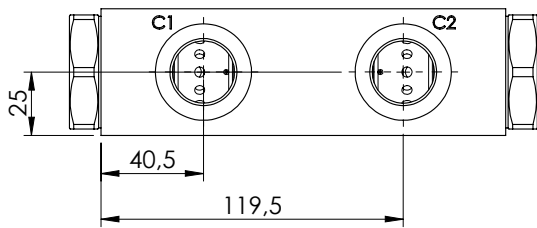
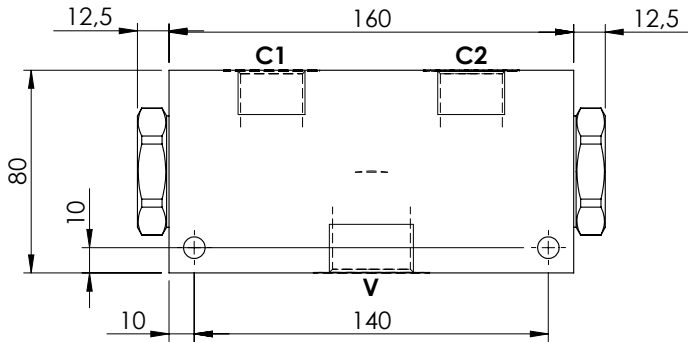
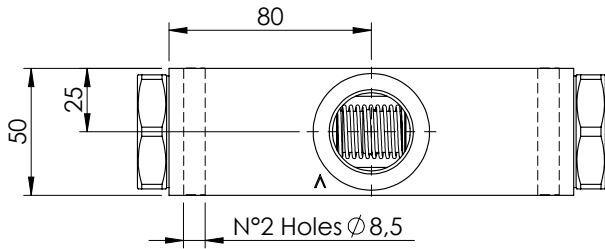

SPECIFICATIONS

Max. operating pressure:	210 bar
Division or combination:	50% - 50%
Manifold:	Aluminium
Weight:	2,1 kg

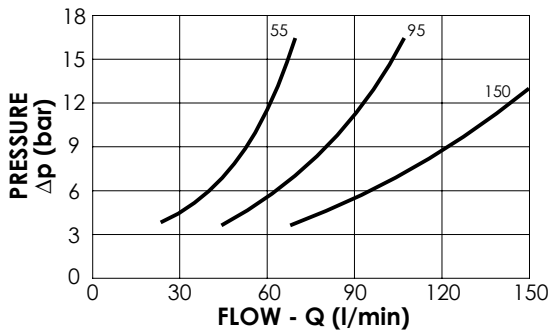

NOTES

Flow divider accuracy: ± 4-5% between 40-100% of max. input flow

ORDERING CODES

Quick code	Description	Main ports size	Inlet range Flow (l/min)	
MF000117	MFDT-150-BFLR-95-G10-N210	V: G 1" C1,C2: G 3/4"	56 - 95	
MF000118	MFDT-150-BFLR-15-G10-N210	V: G 1" C1,C2: G 3/4"	90 - 150	
MF000122	MFDT-150-BFLR-55-G34-N210	V: G 3/4" C1,C2: G 1/2"	28 - 55	
MF000123	MFDT-150-BFLR-95-G34-N210	V: G 3/4" C1,C2: G 1/2"	56 - 95	

FLOW DIVIDER AND COMBINER

KFDT-055-BFAR

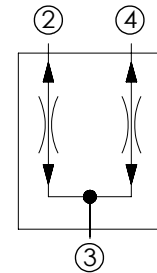
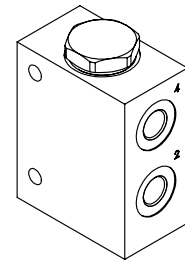
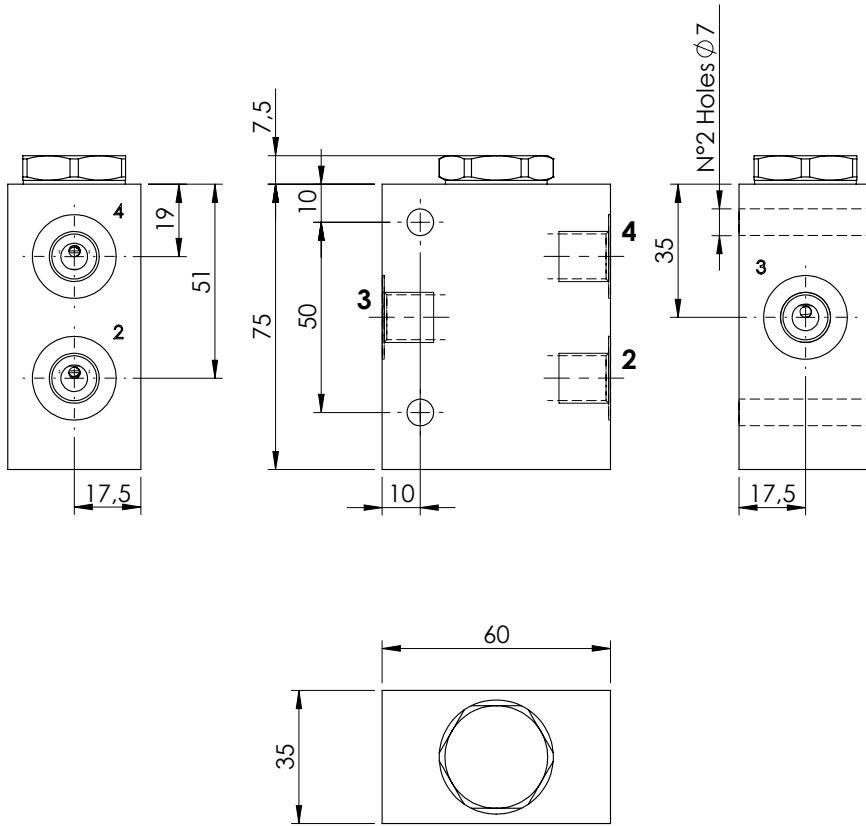

SPECIFICATIONS

Max. operating pressure:	210 bar
Division or combination:	50%-50%
Manifold:	Aluminium
Weight:	0,46 kg
Size:	SAE-10-4N

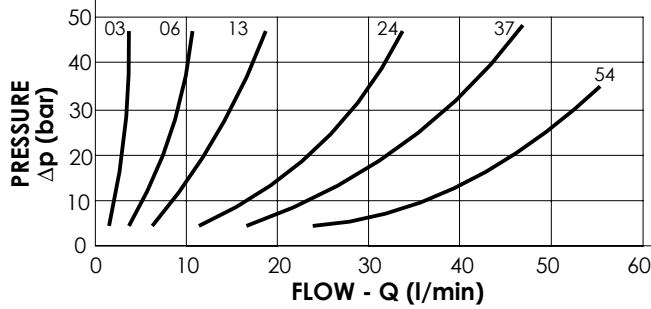

NOTES

Flow divider accuracy: $\pm 7/8\%$ between 40-100% of max. input flow

ORDERING CODES

Quick code	Description	Main ports size	Inlet range Flow (l/min)
KF000005	KFDT-055-BFAR-03-G14-N210-L	2,3,4 : G 1/4"	1.2-3
KF000006	KFDT-055-BFAR-06-G14-N210-L	2,3,4 : G 1/4"	3-6
KF000007	KFDT-055-BFAR-13-G14-N210-L	2,3,4 : G 1/4"	6-13
KF000010	KFDT-055-BFAR-13-G38-N210-L	2,3,4 : G 3/8"	6-13
KF000011	KFDT-055-BFAR-24-G38-N210-L	2,3,4 : G 3/8"	10-24
KF000012	KFDT-055-BFAR-37-G38-N210-L	2,3,4 : G 3/8"	15-37
KF000009	KFDT-055-BFAR-37-G12-N210-L	2,3,4 : G 1/2"	15-37
KF000008	KFDT-055-BFAR-44-G12-N210-L	2,3,4 : G 1/2"	18-44
KF000004	KFDT-055-BFAR-54-G12-N210-L	2,3,4 : G 1/2"	22-54