

PM/PME50

VARIABLE DISPLACEMENT PUMP
CLOSED LOOP CIRCUIT

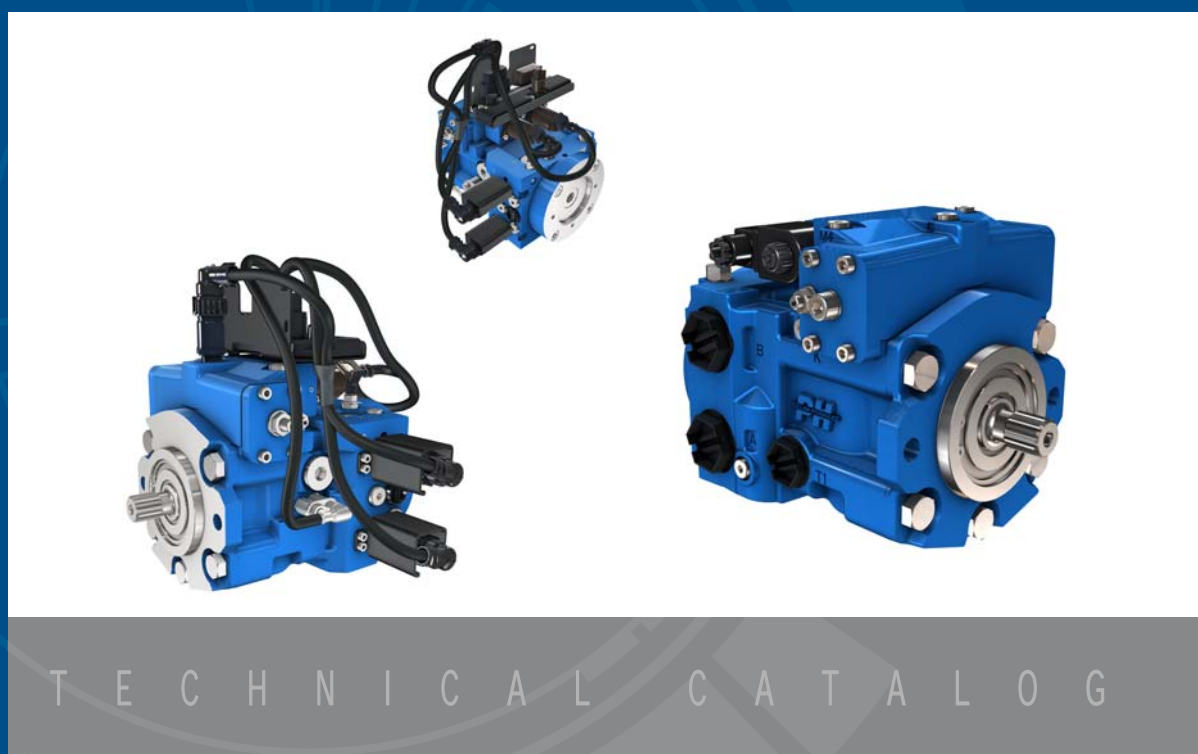

T E C H N I C A L C A T A L O G

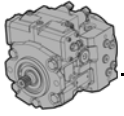

OVERVIEW

PM/PM50 is a variable displacement, axial piston pump, with swashplate system, for closed loop hydrostatic transmissions.

It provides a continuously variable flow rate between zero and maximum in forward and reverse direction. Flow rate is proportional to rotation speed and swashplate angle.

It can feature a charge pump to keep the circuit pressurised. This avoids risk of cavitations and ensures a good performance of the transmission.

It offers several types of control: Hydraulic, electrical and electro-proportional. Hydraulic and electro-proportional ones can be equipped with feedback device.

It is equipped with high pressure relief valves and can be delivered with auxiliary gear pumps.

It is available in single or tandem versions.

As options, PM/PM50 can be featured with flushing valve and filter on charge pressure line. As option, PM50 is equipped with onboard SD-CT-30 and harness.

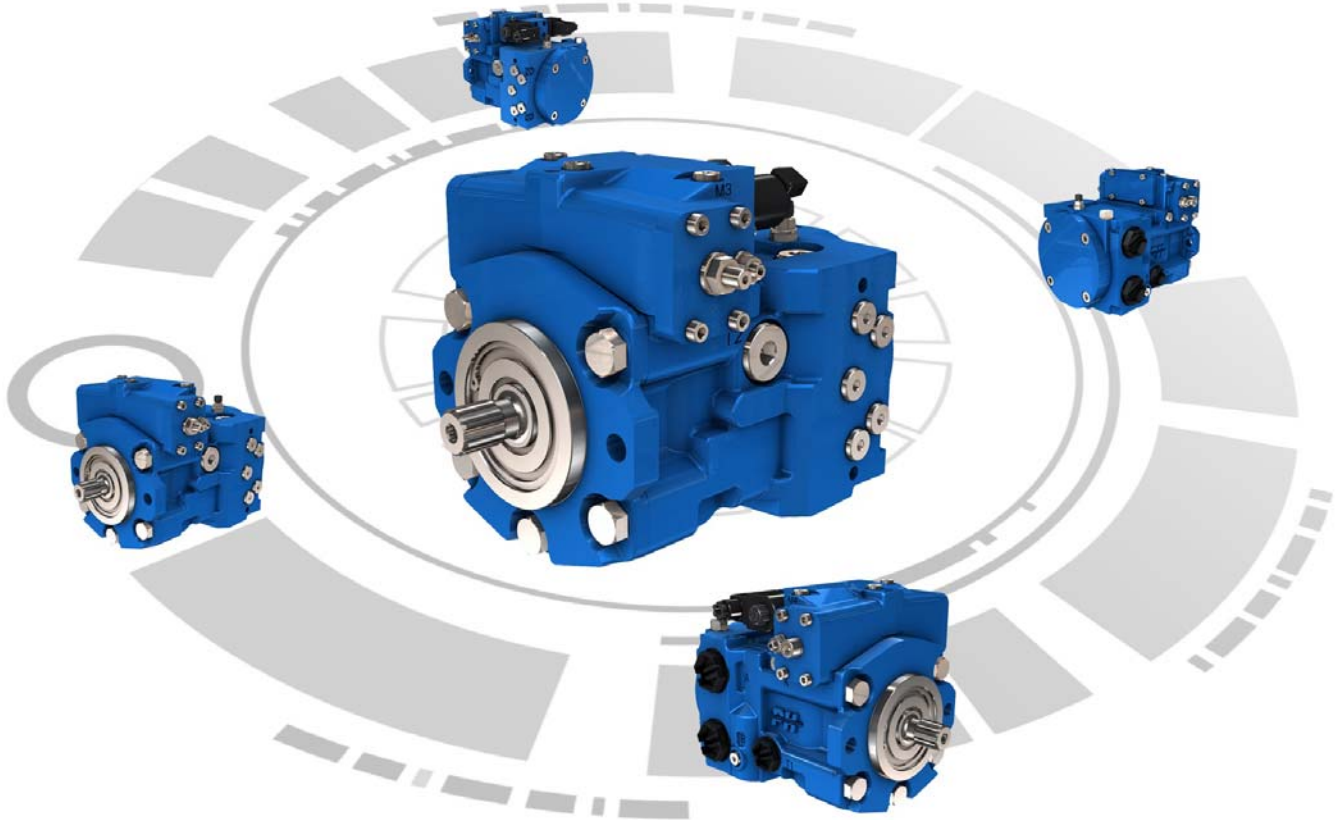

		PM/PM50-40	PM/PM50-45	PM/PM50-52
Displacement	cm ³ /rev [in ³ /rev.]	40 [2.44]	45 [2.75]	52 [3.17]
Theoretical Flow at rated speed	L/min [GPM]	144 [38.04]	162 [42.79]	187,2 [49.45]
Max. Theoretical absorbed power at 320 bar [4 641 PSI]	kW [hp]	76,8 [103]	86,4 [116]	99,8 [134]
Theoretical absorbed torque at 100 bar [1 450 PSI]	N.m [in.lbf]	63,7 [564]	71,7 [635]	82,8 [733]
Moment of inertia	kg.m ² [slug.ft ²]		0.0054 [0.0038]	
Mounting flange			SAE B, SAE BB	
Controls		Servo hydraulic, electrical, electro-proportional		
Mass	kg [lb]	32 [70.5] with servo control S		
Rotation		Clockwise or Counterclockwise		

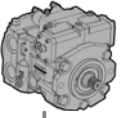

Model
code

Technical
specifications

Operating
parameters

System
parameters

Features

Controls

PMe
package

PMe
installation

Options

Appendixes

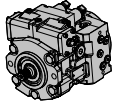

PME PACKAGE 45

List of functions	45
Anti-stall	46
Brake lights	46
Driver presence	47
Temperature protection	47
Over pressure protection	48
Over power protection	48
Engine over speed protection	49
Diagnostic	49
Command device	50
Start-up check	51
Shifting	52
Hill start	53
Proportional engine control	53
Fixed engine control	54
Mixed engine control	55
CAN broadcasting	56
Braking/Inching management	57
Speed control loop	58
CAN slave management	59

PME INSTALLATION 61

Glossary	61
Installation	62
SD-CT-30 pin-out	63
Wiring	64
Auxiliaries	71
CT Design and Phases™ CT	74
SD-CT-30 environmental performances	76
SD-CT-30 input characteristics	76
SD-CT-30 output characteristics	77

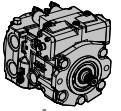

CONTENT

MODEL CODE	6	Model code
TECHNICAL SPECIFICATION	8	Technical specifications
Port characteristics	8	
Main dimensions for PM	9	
Main dimensions for PMe	10	
OPERATING PARAMETERS	11	Operating parameters
Operating parameters	11	
Charge pressure	11	
Case pressure	11	
Pressure ratings	11	
Speed ratings	11	
Inlet pressure	12	
Theoretical output	12	
Poclain Hydraulics recommendations for fluid	12	
Fluid and filtration	13	
Viscosity range	13	
SYSTEM DESIGN PARAMETERS	14	System parameters
Sizing equations	14	
Redundant braking system requirement	14	
Loop flushing	14	
Reservoir	15	
Case drain usage for tandem pump	15	
Differential pressure	15	
Bearing life and external shaft loading	16	
Mounting flange loads	17	
Hydraulic unit life	17	
FEATURES	18	Features
High pressure relief valve	18	
Charge relief valve	19	
Charge pump	20	
By-pass	22	
Displacement limiters	22	
Mounting flange and shafts	23	
Auxiliary mounting pad	25	
Tandem pumps	27	
Gear pumps	29	
CONTROLS	31	Controls
		PMe package
		PMe installation
		Options
OPTIONS	79	Appendixes
APPENDIXES	93	

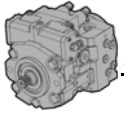

MODEL

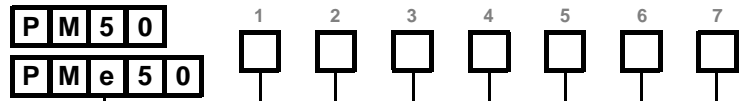

Embedded electronic

Without	-
SD-CT-30 unit	e

1 Displacement cm^3/rev [in^3/rev]

40 [2.44]	40
45 [2.75]	45
52 [3.17]	52



On request the values of max displacement for A/B ports can be different. In this case introduce 2 values, first for port A (for PM pump only).

2 Mounting flange and shaft

SAE B; splined shaft z =13, 16/32" D.P.	S3
SAE BB; splined shaft z =15, 16/32" D.P.	S4 (Standard)
SAE B; splined shaft z =14, 12/24" D.P.	S5
Key shaft	C3

3 Control

Mechanical servo control with feedback	A
Hydraulic servo control	S
Hydraulic servo control with feedback	T
Hydraulic automotive control 12V	D12
Hydraulic automotive control 24V	D24
Electrical on-off servo control with return spring without electrovalve	B00
Electrical on-off servo control with return spring and electrovalve 12V	B12
Electrical on-off servo control with return spring and electrovalve 24V	B24
Electrical on-off servo control without electrovalve	C00
Electrical on-off servo control with electrovalve 12V	C12
Electrical on-off servo control with electrovalve 24V	C24
Electro-proportional servo control 12V	P12
Electro-proportional servo control 24V	P24
Electro-proportional servo control with feedback 12V	Q12
Electro-proportional servo control with feedback 24V	Q24

4 Restrictor mm [in]

Without restrictor	00
\varnothing 0,6 [$\text{dia. } 0.023$]	06
\varnothing 0,7 [$\text{dia. } 0.027$]	07
\varnothing 0,8 [$\text{dia. } 0.031$]	08
\varnothing 0,9 [$\text{dia. } 0.035$]	09
\varnothing 1,0 [$\text{dia. } 0.039$]	10
\varnothing 1,2 [$\text{dia. } 0.047$]	12

5 High pressure relief valve setting

Max. system pressure (bar [PSI])	
Without valve (only check valve)	00
150 [2 175]	15
200 [2 900]	20
250 [3 625]	25
300 [4 351]	30
350 [5 076]	35
370 [5 366]	37
400 [5 801]	40



On request the values of HPRV for A/B ports can be different. In this case introduce 2 values, first for port A (for PM pump only).

6 Rotation

Clockwise	R
Counter clockwise	L

7 Charge relief valve setting bar [PSI]

Without charge relief valve	00
20 [290]	20
25 [363]	25
30 [435]	30

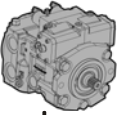

CODE

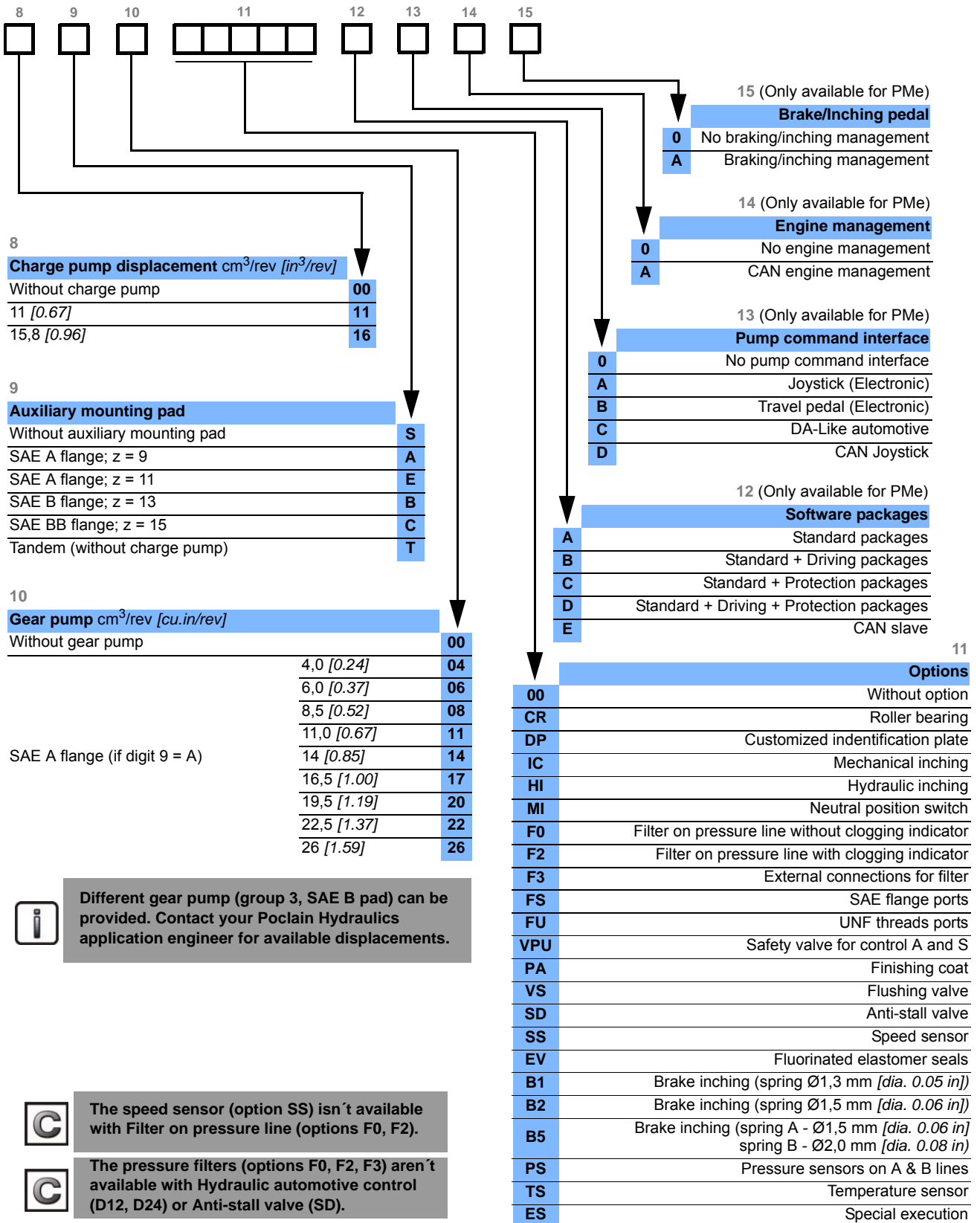

Model code

Technical specifications

Operating parameters

System parameters

Features

Controls

PMe package

PMe installation

Options

Appendixes



Different gear pump (group 3, SAE B pad) can be provided. Contact your Poclair Hydraulics application engineer for available displacements.



The speed sensor (option SS) isn't available with Filter on pressure line (options F0, F2).



The pressure filters (options F0, F2, F3) aren't available with Hydraulic automotive control (D12, D24) or Anti-stall valve (SD).



Mechanical (IC), hydraulics (HI) and brake inchings (B1, B2, B5) are available only with Hydraulic automotive control (D12, D24).



In case of request for a combination of several options, please contact your Poclair Hydraulics application engineer for further information.

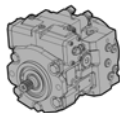

TECHNICAL SPECIFICATIONS

Port characteristics for PM/PM50

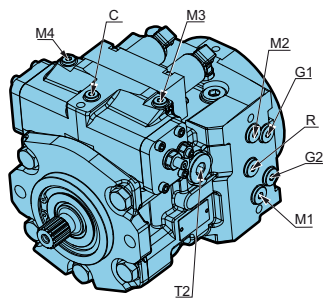
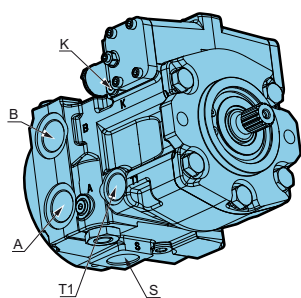

Port	Function	ISO 1179-1 (standard)	Maximum length of nipples [mm] [in]
A/B	Services	34G-G1	
C	Case pressure	13G-G1/4	
G1/G2	Auxiliary/Charge pressure	13G-G1/4	
M1/M2	A/B pressure	10G-G1/8	
M3/M4	Servo control	13G-G1/4	12,5 [0.49]
K	External servo pilot	10G-G1/8	
R	Servo pilot pressure	13G-G1/4	
S	Suction	34G-G1	
T1/T2	Drain	27G-G3/4	

See options FS and FU on page 81 for SAE flange and UNF port size.

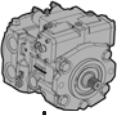

Main dimensions for PM50

PM50 - SAE BB - splined shaft with hydraulic servo control, internal charge pump and without auxiliary mounting pad

	1	2	3	4	5	6	7	8	9	10	11
P		S4	S						S		

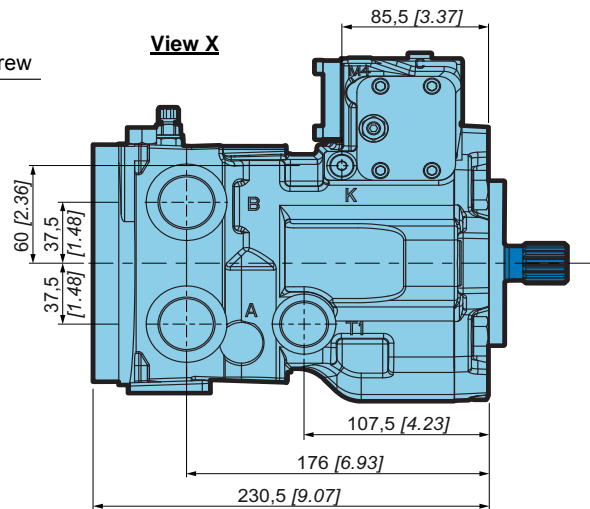
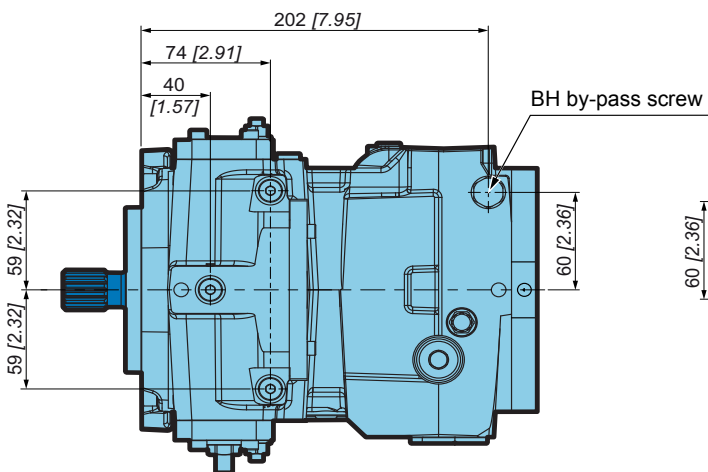
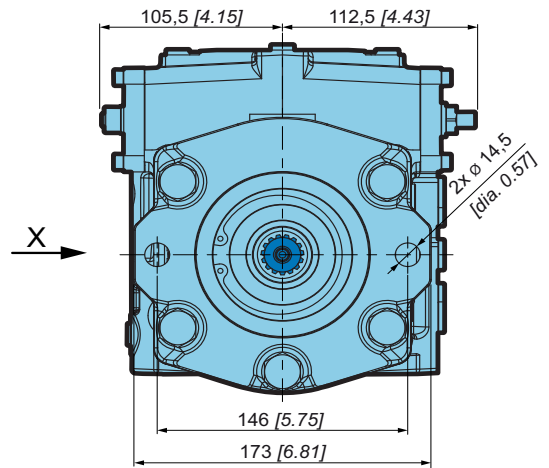
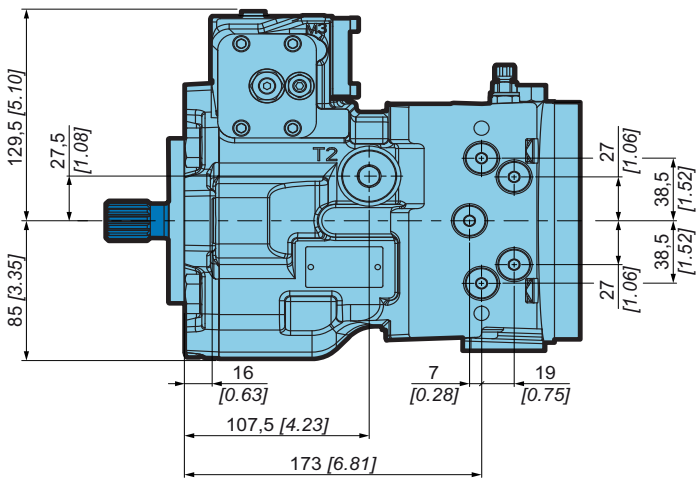
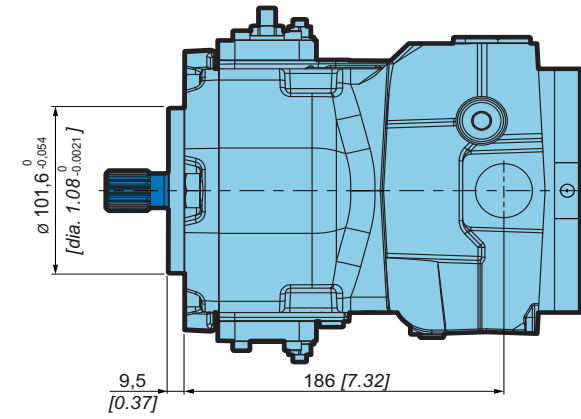

Model code

Technical specifications

Operating parameters

System parameters

Features

Controls

PMe package

PMe installation

Options

Appendixes

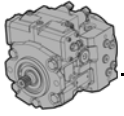

Main dimensions for PMe50

PMe50 - SAE BB - splined shaft with electroproportional servo control, internal charge pump, pressure sensors on A&B lines, speed sensor, temperature sensor and without auxiliary mounting pad

	1	2	3	4	5	6	7	8	9	10	11	12	13	14	15
P	M	e	5	0		S4	P12								
										S		PSSSTS			

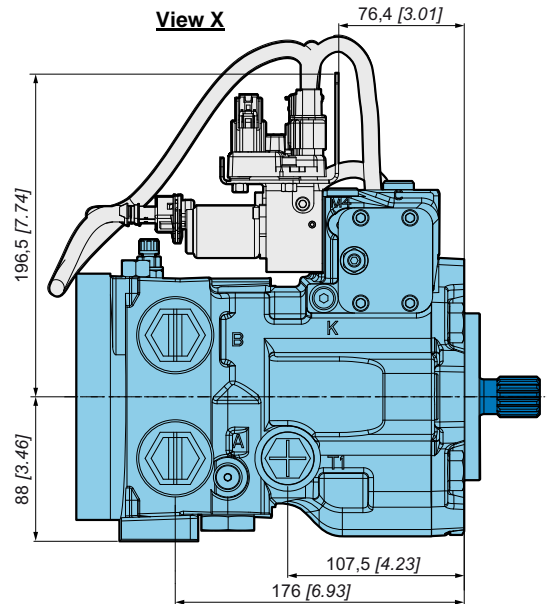
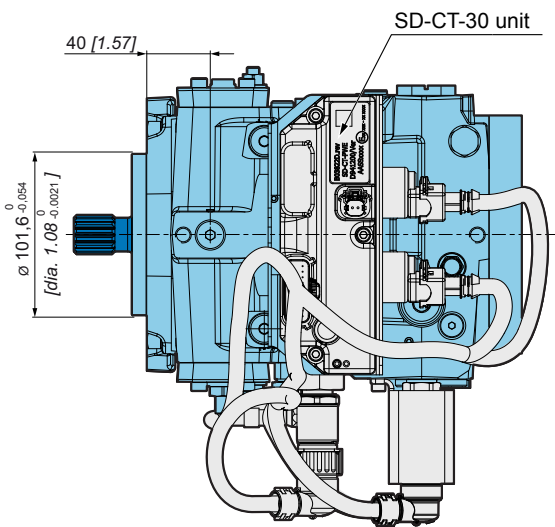
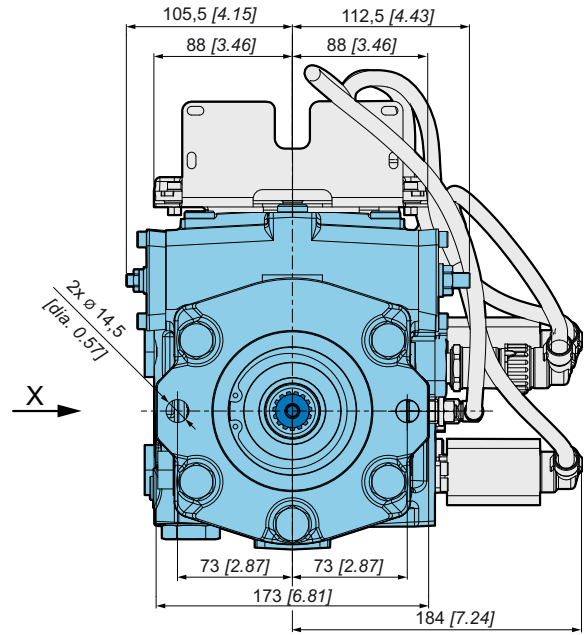
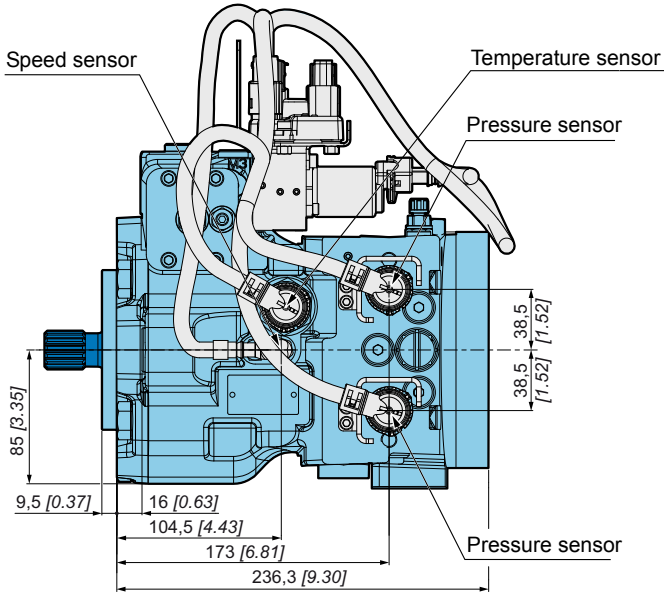

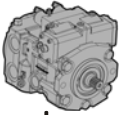

OPERATING PARAMETERS

Operating parameters

		PM/PMe50-40	PM/PMe50-45	PM/PMe50-52
Speed ratings	Minimum		700	
	Max. without load	min ⁻¹ (rpm)	3 600	
	Max. with load		3 400	
System pressure	Rated		300 [4 351]	
	Maximum	bar [PSI]	400 [5 801]	
	Minimum low loop		15 [218]	
Inlet pressure	Mini continuous	bar (abs.)	0,8 [11.6]	
	Mini (cold start)	[PSI abs.]	0,5 [7.2]	
Case pressure	Continuous	bar [PSI]	2 [29]	
	Maximum (cold start)		3,5 [50.7]	
Charge pressure	Standard version	bar [PSI]	25 [362.6]	
	Max. charge pressure		30 [435]	
Servo case pressure	Maximum	bar [PSI]	30 [435]	

Charge pressure

A charge flow is required to maintain a positive pressure in the low pressure loop of a closed loop hydrostatic transmission. Charge pressure ensures proper lubrication and rotating group operation. It is recommended to maintain the charge pressure at a minimum of 15 bar [218 PSI] above case pressure. For more details, refer to charge pump paragraph, page 18.

Case pressure

Case pressure must be maintained within the limits shown in the table "Operating parameters". Ensure housing is always filled with hydraulic fluid and especially during start-up of the machine.

Pressure ratings

Maximum peak pressure

It is the maximum allowable pressure. It is equivalent to the maximum setting of the maximum high pressure relief valve. A self-propelled machine can reach the maximum peak pressure value no more than 1-2% of that work cycle.

Work cycle

A fundamental factor for ensuring correct hydrostatic transmission sizing is the machine work cycle (pressure-time ratio, seasonality, pressure vs. percentage of time at max. displacement, machine type). Part service life depends on the correct choice in relation to the work cycle.

Overloads

It is mandatory to protect parts against any possible overloads.

Speed ratings

The table "Operating parameters" gives minimum and maximum rated speeds. Note that all displacements might operate under different speed limits. Definitions of these speed limits appear below.

Maximum speed is the highest operating speed allowed. Over speeding reduces pump life time, can lead to loss of hydrostatic power and braking capacity. Never exceed the maximum speed limit under any operating conditions.

Nominal speed is the speed offering the maximal efficiency.

Model
codeTechnical
specificationsOperating
parametersSystem
parameters

Features

Controls

PMe
packagePMe
installation

Options

Appendixes

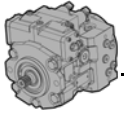

Inlet pressure

Charge pump inlet pressure is key for acceptable pump life and performances. A continuous inlet pressure of not less than 0,8 bar abs. [11.6 PSI abs.] is recommended. A continuous inlet pressure less than 0.5 bar abs. [7.2 PSI abs.] indicates inadequate inlet design or a restricted filter. Pressures less than 0.5 bar abs. [7.2 PSI abs.] can happen at cold start, but should increase with oil temperature.

Theoretical output

Theoretical output flow is a function of pump displacement and speed. It is relevant to size the rest of the circuit. Theoretical flow does not take into account losses due to leakage or variations in displacement. Refer to performances, page 6, for volumetric and overall efficiencies at various operating speeds and pressures.

Poclain Hydraulics recommendations for fluid



Poclain hydraulics recommends the use of hydraulic fluids defined by the ISO 15380 and ISO 6743-4 standards. For temperate climates, the following types are recommended.

- HM 46 or HM 68 for fixed installations.
- HV 46 or HV 68 for mobile installations.
- HEES 46 for mobile installations.

These specifications correspond to category 91H of the CETOP standard, parts 1, 2 and 3 of the DIN 51524 standard, and grades VG32, VG 46 and VG68 of the ISO 6743-4 standards.



It is also possible to use ATF, HD, HFB, HFC or HFD type hydraulic fluid upon Poclain Hydraulics specific approval of the components' operating conditions.

Standardized designations for the fluids

- **HM** : Mineral fluids having specific antioxidant, anticorrosion and antiwear properties (HLP equivalent to DIN 51524 parts 1 and 2).
- **HV** : HM mineral fluids providing improved temperature and viscosity properties (DIN 51524 part 3).
- **HEES** : Biodegradable fluids based on organic esters.



It is also possible to use a fluid that meets the biodegradability criteria and is compatible in the event of accidental food contact. The BIOHYDRAN FG 46 fluid designed by the company Total has undergone testing of its properties and performance on our test benches. Since this type of fluid has not yet been categorized, it is the responsibility of machine manufacturers to validate its compatibility with all of the components used in order to guarantee that the intended functions will be fulfilled and this for the desired life time of all equipment items.



For biodegradable fluids, consult your Poclain Hydraulics' application engineer



During operation, the temperature of the oil must be between 0°C [32°F] and 80°C [176°F]; the minimum and maximum temperatures may be exceeded momentarily by ± 20°C [± 68°F] for a duration of less than 30 minutes. For all applications outside these limits, please consult with your Poclain Hydraulics' application engineer.

Pump storage



If the pump stays on stock for more than 6 months, a status verification must be performed before you install it on a machine. Pay attention to sealing condition, rust presence and free rotation of shaft.

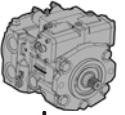

Fluid and filtration

The contaminating particles suspended in the hydraulic fluid cause the hydraulic mechanisms moving part wear. On hydraulic pumps, these parts operate with very small dimensional tolerances. In order to reach the part life, it is recommended to use a filter that maintains the hydraulic fluid contamination class at a max. of:

- 9 according to NAS 1638
- 20/18/13 according to ISO 4406:1999

According to the type of application decided for the pump, it is necessary to use filtration elements with a filtration ratio of:

$$\beta_{20 \text{ to } 30} \geq 100$$

Making sure that this ratio does not worsen together with the increasing of the filter cartridge differential pressure. If these values cannot be observed, the component life will consequently be reduced and it is recommended to contact the Poclair Hydraulics Customer Service.

Filters on charge circuit

Filters on the charge circuit (F0-F2) are designed without by-pass. The max. pressure drop on the filtration part must not exceed 2 bar [29 PSI] (3 bar [43.5 PSI] in case of cold starting) at pump full rating. To monitor the pressure drop, it is recommended to use the clogging indicator on the filtration element (F2 option). Contact your Poclair Hydraulics Application engineer, each time the pump is not charged by its internal charge pump.

Filters on charge circuit are mounted on the pump special support.

Filters assembling

The suction filter is mounted on the suction line. Check that the pressure before the charge pump is 0.8 bar abs. [11.6 PSI abs.], measured on the pump suction port (0.5 bar [7.2 PSI] for cold starting).

Viscosity range

For both max. efficiency and life of the unit, the operative viscosity should be chosen within the optimum range of:
 ν_{opt} = optimum operating viscosity from 16 to 36 mm²/s [from 74.1 to 166.8 SUS] referred to the closed loop temperature.

Working conditions: the following limits of viscosity apply

ν_{min} = 5 mm²/s [23 SUS] short-duration at a max. permissible leakage oil temperature of 90° C [194°F]

ν_{max} = 1000 mm²/s [4 634 SUS] short-duration, on cold start.

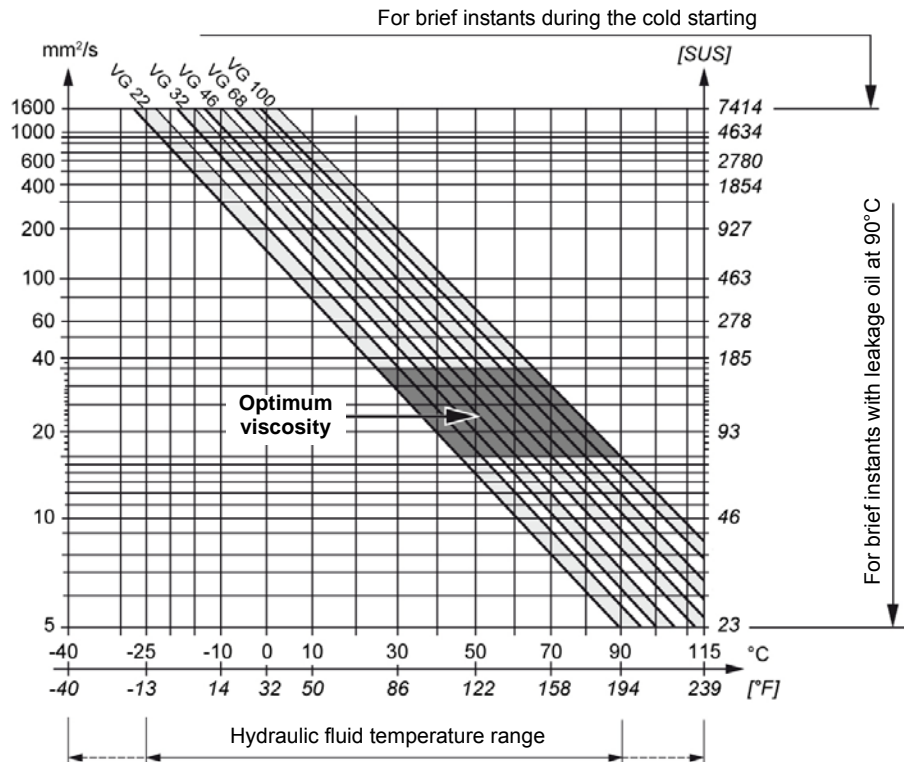

Ensure fluid temperature and viscosity limits are concurrently satisfied.

- Model code
- Technical specifications
- Operating parameters
- System parameters
- Features
- Controls
- PMe package
- PMe installation
- Options
- Appendixes

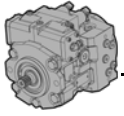

SYSTEM DESIGN PARAMETERS



Consult your Poclain Hydraulics application engineer to validate your design parameters before using the pump in your application.

Sizing equations

The following equations are helpful when sizing hydraulic pumps. Generally, the sizing process is initiated by an evaluation of the machine system to determine the required motor speed and torque to perform the necessary work function. First, the motor is sized to transmit the maximum required torque. The pump is then selected as a flow source to achieve the maximum motor speed.

	Output flow Q	$= \frac{V_g \cdot n \cdot \eta_v}{1000}$	(l/min)
SI units	Input torque M	$= \frac{V_g \cdot \Delta p}{20 \cdot \pi \cdot \eta_m}$	(N.m)
	Input power P	$= \frac{M \cdot n \cdot \pi}{30\,000} = \frac{Q \cdot \Delta p}{600 \cdot \eta_t}$	(kW)
	Output flow Q	$= \frac{V_g \cdot n \cdot \eta_v}{231}$	[GPM]
US units	Input torque M	$= \frac{V_g \cdot \Delta p}{2 \cdot \pi \cdot \eta_m}$	[lbf.in]
	Input power P	$= \frac{M \cdot n \cdot \pi}{198\,000} = \frac{Q \cdot \Delta p}{1714 \cdot \eta_t}$	[hp]

V_g = Displacement per revolution cm^3/tr [in^3/rev]
 Δp = $p_o - p_i$ (system pressure) bar [PSI]
 n = Speed min^{-1} [rpm]
 η_v = Volumetric efficiency
 η_m = Mechanical efficiency
 η_t = Overall efficiency ($\eta_v \cdot \eta_m$)

Redundant braking system requirement



Unintended vehicle or machine movement hazard.
 The loss of hydrostatic drive line power, in any mode of operation (forward, neutral, or reverse) may cause the system to lose hydrostatic braking capacity. You must provide a braking system, redundant to the hydrostatic transmission, sufficient to stop and hold the vehicle or machine in the event of hydrostatic drive power loss.

Loop flushing

Closed circuit may require a flushing valve to meet temperature and cleanliness requirements. A flushing valve takes a part of hot fluid flow from the low pressure loop of the system loop for cooling and filtering. Make sure that the charge pump provides adequate flow for the flushing valve flushing and the flushing valve does not cause charge pressure to drop below recommended limits.

See option VS page 85 for more information.

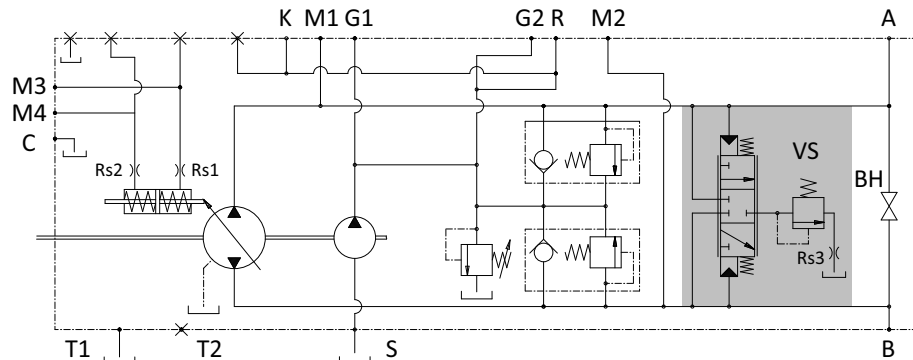

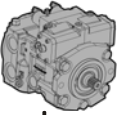

Reservoir

The reservoir provides clean fluid, dissipates heat, and removes entrained air from the hydraulic fluid. It allows for fluid volume changes associated with fluid expansion and cylinder differential volumes. Minimum reservoir capacity depends on the volume needed to perform these functions. Typically, a capacity of one half the charge pump flow (per minute) is satisfactory for a closed reservoir. Open circuit systems sharing a common reservoir require greater fluid capacity.

Locate the reservoir outlet (suction line) near the bottom, allowing clearance for settling foreign particles. Use a 100 - 125 µm screen covering the outlet port.

Place the reservoir inlet (return lines) below the lowest expected fluid level, as far away from the outlet as possible.

Use a baffle (or baffles) between the reservoir inlet and outlet ports to promote de-aeration and reduce fluid surging.

Case drain usage for tandem pump

To ensure lubrication of both pumps (with only one charge pump), excess flow from the second pump charge relief valve must be routed into the housing of the first pump.



Tandem pumps with the option of opposing port endcaps do not follow the above rule.

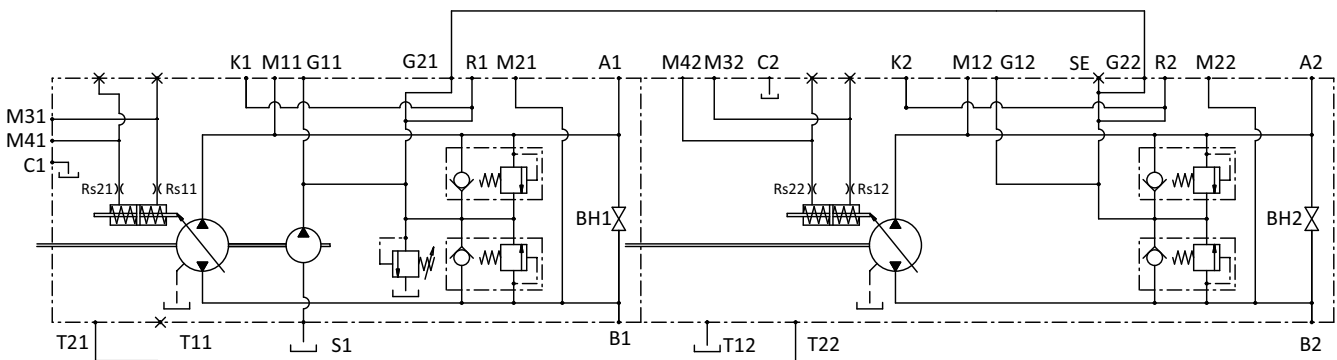

Differential pressure

The differential pressure is the High pressure relief valve setting minus Charge relief valve setting.

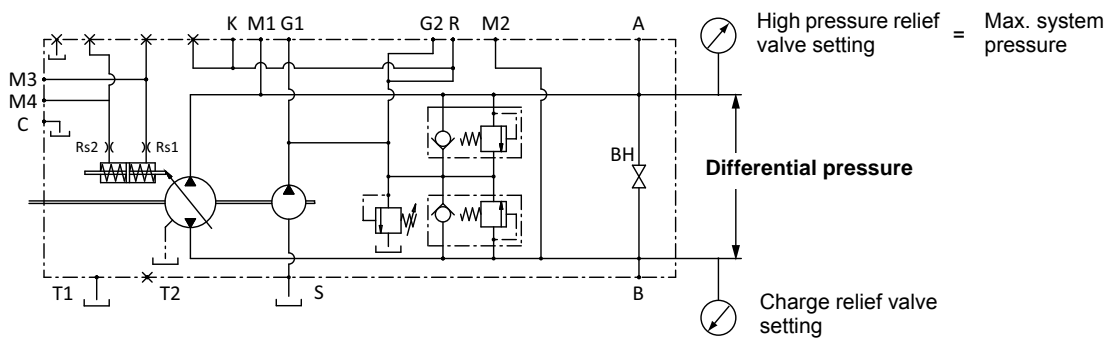

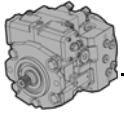

Bearing life and external shaft loading

Bearing life:

Bearing life is a function of speed, pressure, swashplate angle and external loads. Oil type and viscosity impact bearing life.

	Ball bearing life (B ₁₀ hours)	Roller bearing life (B ₁₀ hours)
PM/PMe50-40	21 000	39 000
PM/PMe50-45	14 500	27 000
PM/PMe50-52	9 500	18 000

Shaft Loads

Normal bearing life in B₁₀ hours is shown in the above table. Figures have been calculated under the following operating conditions: A continuous differential pressure of 150 bar [2 176PSI], 1 800 rpm shaft speed, maximum displacement, without any external shaft side load. The data is based on a 50% forward, 50% reverse duty cycle, standard charge pump size, and standard charge pressure.

PM50 pumps are designed with bearings that can accept external radial and thrust loads. The external radial shaft load limits depend on the load position, orientation, and operating conditions of the unit.

The maximum permissible radial load (Re), is based on the maximum external moment (Me), and the distance (L) from the mounting flange to the load. It may be determined using the table and formula below. Thrust (axial) load limits are also shown.

$$Re = Me / L$$

All external shaft loads affect bearing life. In applications with external shaft loads, minimize the impact by positioning the load at 90° or 270° as shown in the figure.

Contact your Poclain Hydraulics representative for an evaluation of unit bearing life if:

- Continuously applied external loads exceed 25 % of the maximum allowable radial load Re.
- The pump swashplate is positioned on one side of center all or most of the time.
- The unit bearing life (B₁₀) is critical.

	External moment (Me) N.m [in.lbf] (Based on shaft deflection)	Maximum shaft thrust N [lbf] (at ΔP 180 bar [2 611 PSI] and 3 400 rpm)
PM/PMe50-40	150 [1 328]	1 500 [337]
PM/PMe50-45	107 [947]	1 500 [337]
PM/PMe50-52	76 [673]	1 500 [337]

Radial and thrust load position

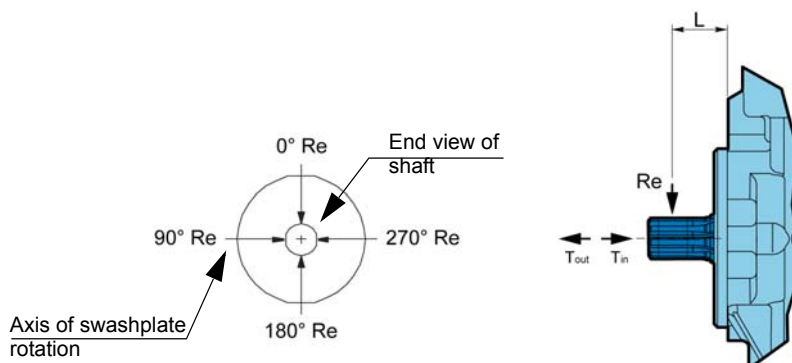

For an accurate calculation, consult your Poclain Hydraulics application engineer.

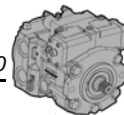

Hydraulic unit life

Hydraulic unit life is the life expectancy of the hydraulic components. It depends on speed and system pressure even if , system pressure is the dominant operating variable. High pressure, generated by high load, reduces hydraulic unit life.

Design the hydraulic system according to the expected machine duty cycle. Take in consideration the expected percentages of time at various loads and speeds. Ask your Poclain Hydraulics representative to calculate an appropriate pressure based your hydraulic system design. If duty cycle data is not available, input power and pump displacement are used to calculate system pressure.

All pressure limits are differential pressures (referenced to charge pressure) , taking a normal charge pressure in consideration.

PM50 pumps will meet satisfactory life expectancy if applied within the parameters specified in this technical documentation. For more detailed information on hydraulic unit life see Operating Parameters in page 9.

Mounting flange loads

Adding tandem mounted pumps, and/or tandem auxiliary pump(s), subjecting pumps to shock loads may generate excessive loads on the front mounting flange. The overhung load moment for multiple pump mounting can be estimated as shown in the figure below

Overhung load example

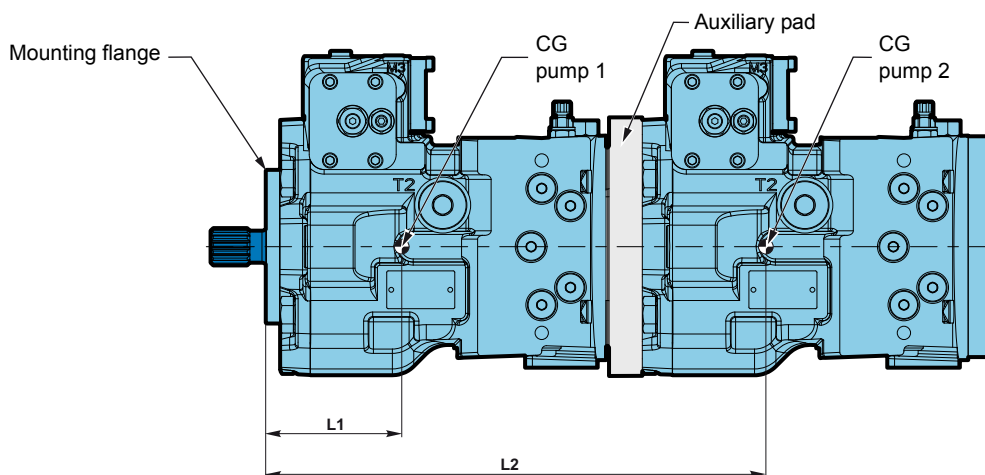

For two PM50 in tandem the approximate distances (exact values depend on pumps configuration) of gravity centers from front mounting flange are:

- L1 = 92 mm [3.62 inch]
- L2 = 330 mm [12.99 inch]

Estimating overhung load moments

- W = Weight of pump (kg)
- L = Distance from mounting flange to pump center of gravity (CG)
- $M_R = G_R (W_1L_1 + W_2L_2 + \dots + W_nL_n)$
- $M_S = G_S (W_1L_1 + W_2L_2 + \dots + W_nL_n)$

Where:

- M_R = Rated load moment (N.m)
- M_S = Shock load moment (N.m)
- G_R^* = Rated (vibratory) acceleration (G's) (m/sec²)
- G_S^* = Maximum shock acceleration (G's) (m/sec²)

*Calculations will be carried out by multiplying the gravity (g = 9.81 m/sec²) with a given factor. This factor depends on the application.

Allowable overhung load moment are shown in the above table. Exceeding these values requires additional pump support.

	Rated moment (MR)	Shock load moment (MS)
	N.m [in.lbf]	N.m [in.lbf]
PM/PMe50-40	900 [7 966]	2 000 [17 701]
PM/PMe50-45	900 [7 966]	2 000 [17 701]
PM/PMe50-52	900 [7 966]	2 000 [17 701]



For an accurate values and calculations, consult your Poclain Hydraulics application engineer.

Model code

Technical specifications

Operating parameters

System parameters

Features

Controls

PMe package

PMe installation

Options

Appendixes

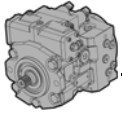

FEATURES

High pressure relief valve

The High pressure relief valves maintain circuit pressure in the proper range. The check valves allow charge flow to replenish the low pressure loop of the circuit. The high pressure relief valves ensure a high pressure protection of the high pressure loop of the circuit.

High pressure relief valves are available in a large range of settings. They are not adjustable. When high pressure relief valves are not desired, pumps may be equipped with charge circuit check valves only. On request the setting of the max displacement can be different, in this case two values must be indicated in order code (first for port A).



High pressure relief valves are intended for transient overpressure protection and are not intended for continuous pressure control. Flow over relief valves for extended periods of time may result in severe heat build up. High flows over relief valves may result in pressure levels exceeding the nominal valve setting and potential damage to system components.



High pressure relief valve	Available setting bar [PSI]	
Without	-	00
	150 [2 175]	15
	200 [2 900]	20
With	250 [3 625]	25
	300 [4 351]	30
	350 [5 076]	35
	370 [5 366]	37
	400 [5 801]	40

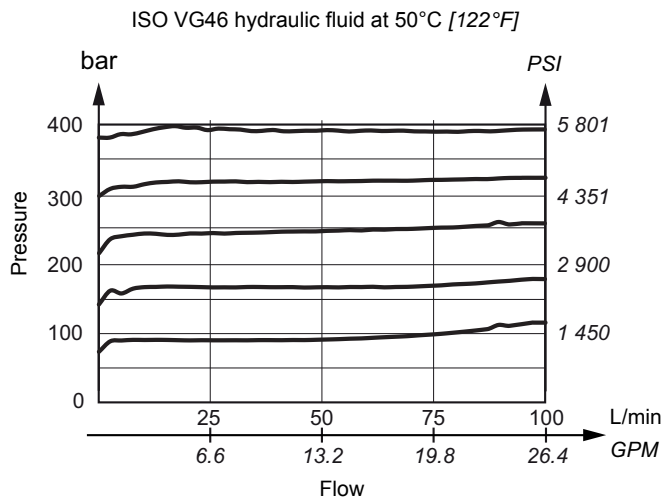
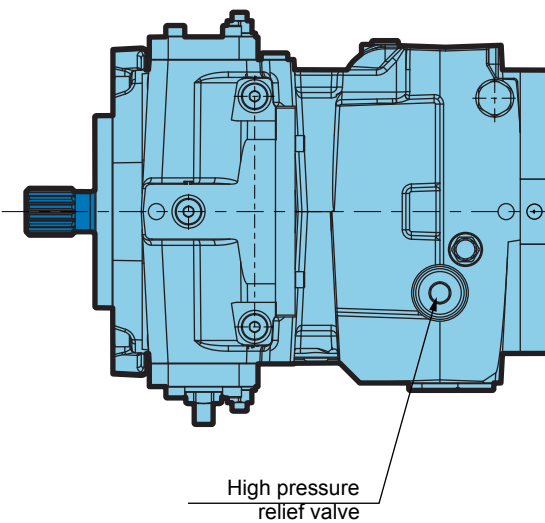
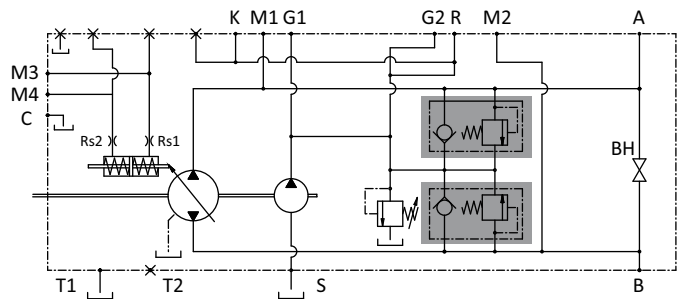

To check close loop pressure use ports M1-M2.

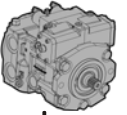

Charge relief valve

The charge pressure relief valve provides a relief outlet for charge circuit. This valve is used to set the charge pressure of the circuit. Flow through the valve is ported to case.

The nominal charge relief setting is referenced to case pressure.



Incorrect charge pressure settings may result in the inability to build required system pressure and/or inadequate loop flushing flows. Ensure correct charge pressure under all conditions of operation to maintain pump control performance.

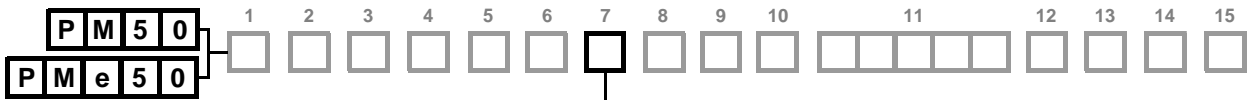

Charge relief valve	Available setting bar [PSI]	
Without	-	00
With	20 [290]	20
With (standard)	25 [363]	25
With	30 [435]	30

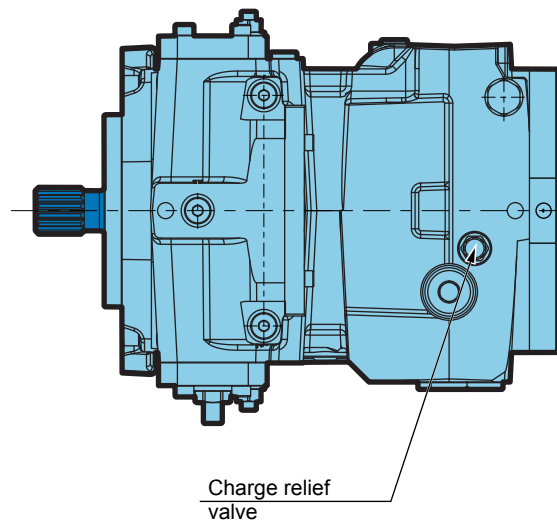
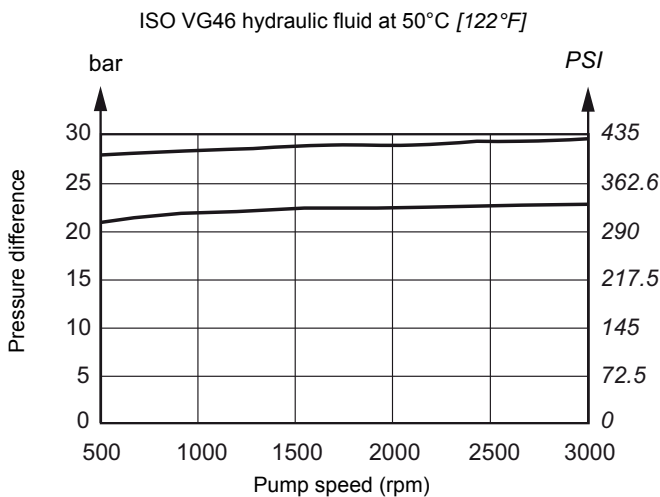
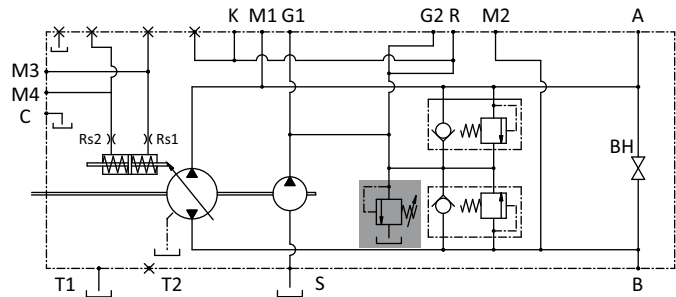

To check charge pressure use ports G1-G2.

Model code

Technical specifications

Operating parameters

System parameters

Features

Controls

PMe package

PMe installation

Options

Appendixes

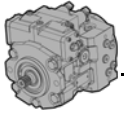

Charge pump

Charge flow is required on all PM/PM50 pumps used in closed circuit installations. The charge pump provides flow to make up internal leakage, maintain a positive pressure in the main circuit, provide flow for cooling and filtration, replace any leakage losses from external valving or auxiliary systems, and to provide flow and pressure for the control system.

Many factors influence the charge flow requirements. These factors include system pressure, pump speed, pump swashplate angle, type of fluid, temperature, size of heat exchanger, length and size of hydraulic lines, control response characteristics, auxiliary flow requirements, hydrostatic motor type, etc.

Unusual application conditions may require a more detailed review of charge pump sizing. Charge pressure must be maintained at a specified level under all operating conditions to prevent damage to the transmission. Poclain Hydraulics recommends testing under actual operating conditions to verify this.

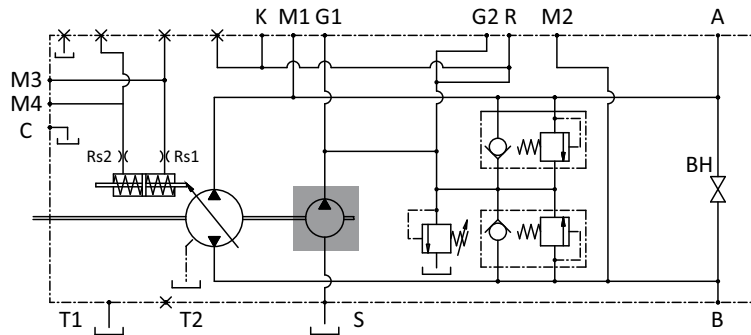

Charge pump sizing / selection

In most applications a general guideline is that the charge pump displacement should be at least 20% of the main pump displacement.

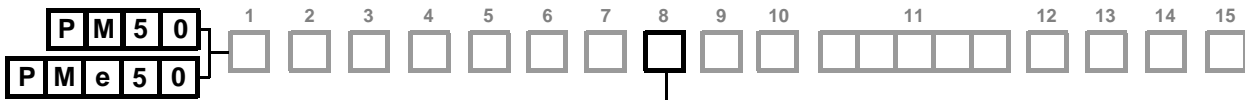

Charge pump	Displacement cm ³ /rev [in ³ /rev]	Rated speed (rpm)	
Without	-	-	00
With	11 [0.67]	3600	11
	15,8 [0.96]	3600	16



Contact your Poclain Hydraulics application engineer for more information.

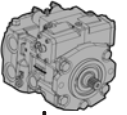

Without charge pump



The external charge flow must be the same that the internal charge pump flow and connected with port S. PM/PMe50 without internal charge pump is shorter, respect standard with internal charge pump.

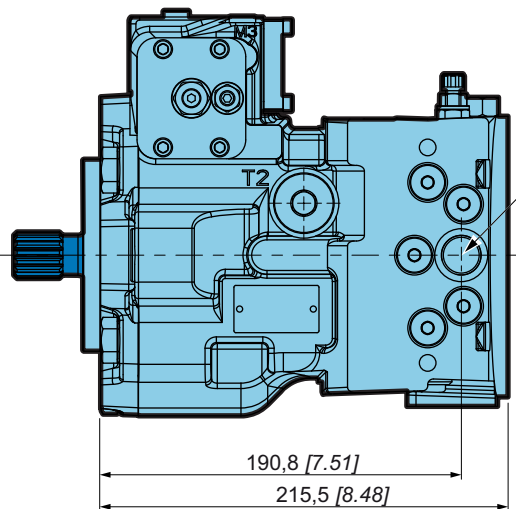
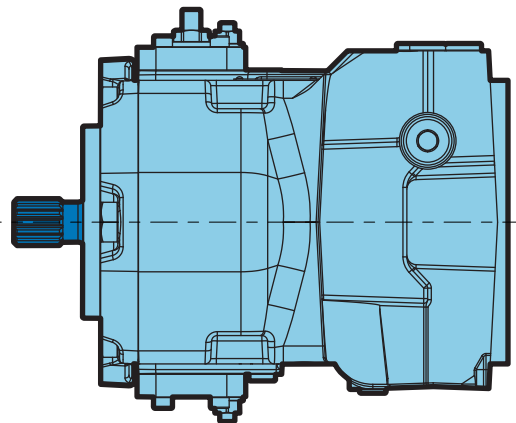
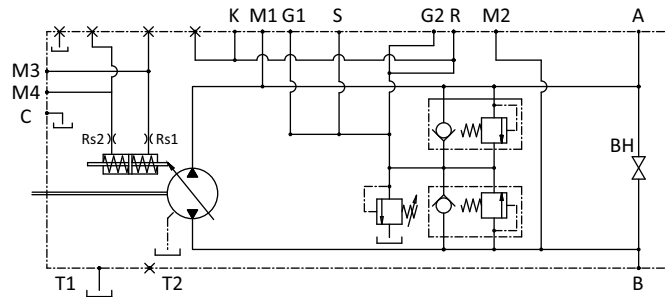

Model code

Technical specifications

Operating parameters

System parameters

Features

Controls

PMe package

PMe installation

Options

Appendixes

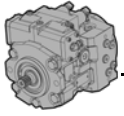

Displacement limiters

PM50 are designed with mechanical displacement (stroke) limiters. You can limit maximum displacement of the pump to a certain per-cent of its maximum displacement to near zero in both direction.

The displacement limiters are located on the both sides of the servo piston and are adjustable by screw. On request the setting of the max. displacements can be different, in this case two values must be indicated in order code (first for port A).



Take care in adjusting displacement limiters to avoid an undesirable condition of output flow or speed. Retorque the sealing lock nut after every adjustment to prevent an unexpected change in output conditions and to prevent external leakage during pump operation.

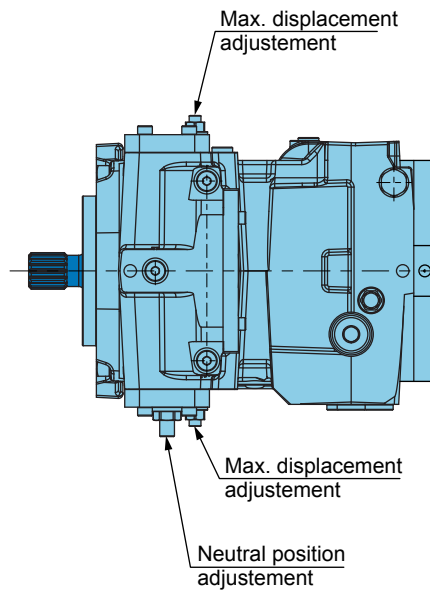

By-pass

PM/PM50 features a by-pass function. By-passing Port A and Port B is achieved by unscrewing a screw located on the cover. The by-pass connect the ports A-B and must be use only in emergency case and only for short movement.

By-pass, wrench M17

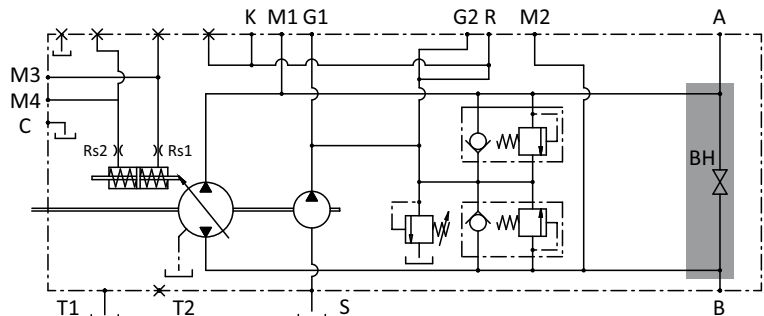
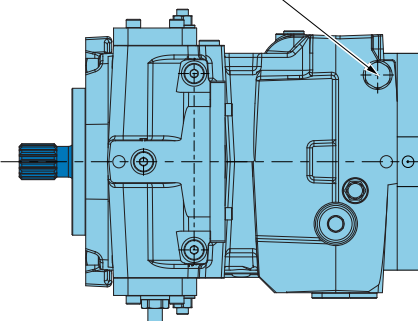

To avoid leakage, do not exceed two turns of the screw.



By-pass valve is intended for moving a machine for very short distances at very slow speeds. It isn't intended as tow valve.

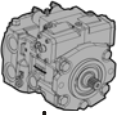

Mounting flange and shafts



S3 SAE B - Splined shaft

13 teeth; Max. torque: 220 Nm [1947 in.lbf]

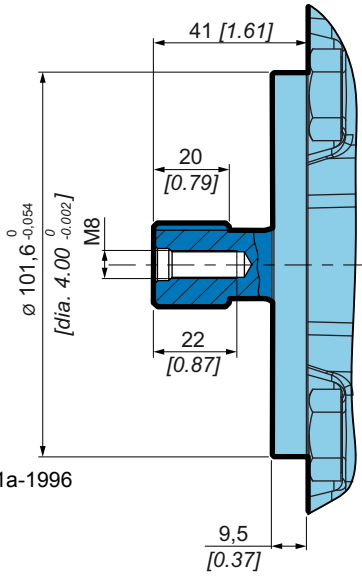

Splined ANSI B92.1a-1996
Pitch 16/32" DP
Pressure angle 30°
Tolerance class: 5

S4 SAE BB - Splined shaft (standard)

15 teeth; Max. torque: 360 Nm [3186 in.lbf]

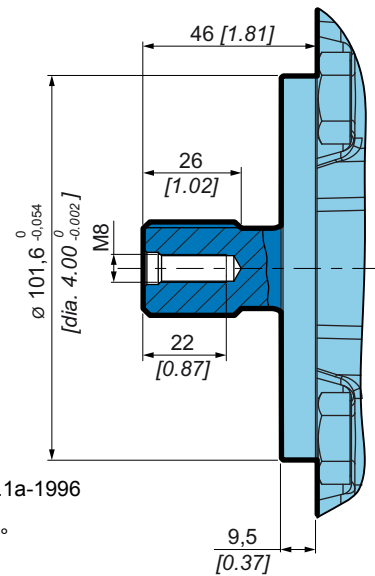

Splined ANSI B92.1a-1996
Pitch 16/32" DP
Pressure angle 30°
Tolerance class: 5

S5 SAE B - Splined shaft

14 teeth; Max. torque: 600 Nm [5310 in.lbf]

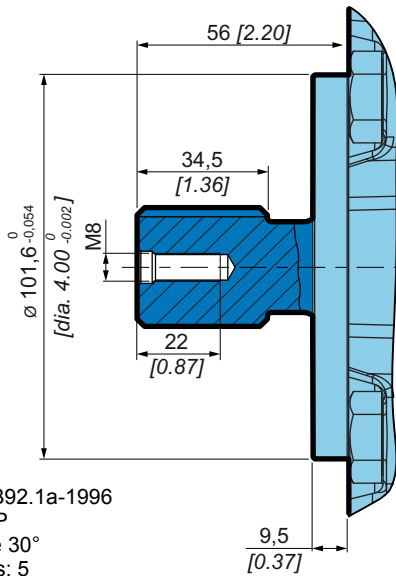

Splined ANSI B92.1a-1996
Pitch 12/24" DP
Pressure angle 30°
Tolerance class: 5

C3 SAE B - Key shaft

Ø = 22,22 mm [dia. 0.87 in]; Max. torque: 220 Nm [1947 in.lbf]

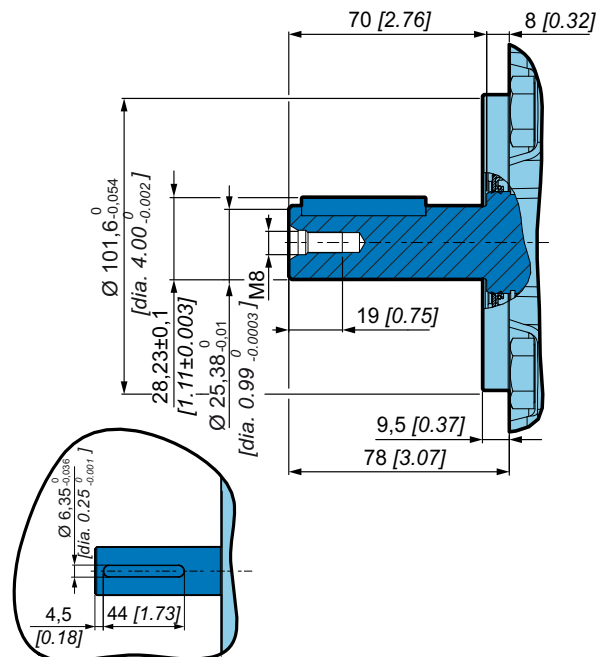

Model code

Technical specifications

Operating parameters

System parameters

Features

Controls

PM e package

PM e installation

Options

Appendixes

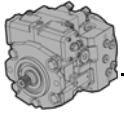

Fundamental dimensions for coupling assembly

To avoid the contact between rotating and fixed parts the below dimensions for coupling must be observed.

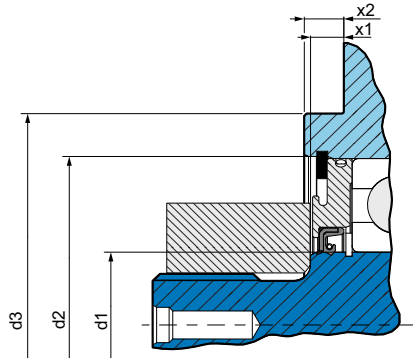

Size	$\varnothing d_1$	$\varnothing d_2$	$\varnothing d_3$	x_1	x_2
PM50	35 [1.38]	81 ^{+0,1} [3.19 ^{+0.004}]	101,6 [3.99]	8 [0.31]	9,5 ^{-0,1} [0.37 ^{-0.004}]



For precise info regarding coupling assembly contact your Poclain Hydraulics application engineer.

Closed cover



00	Without charge pump
11	With charge pump: 11,0 cm ³ /rev [0.67 in ³ /rev]
16	With charge pump: 15,8 cm ³ /rev [0.96 in ³ /rev]

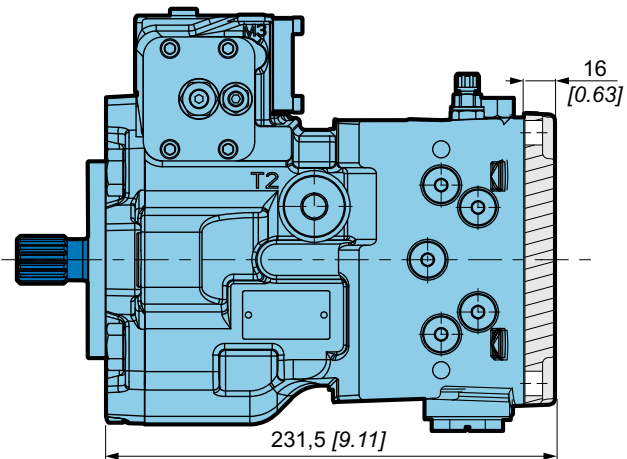
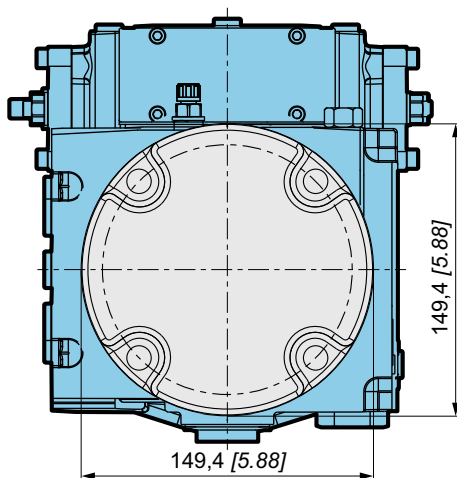

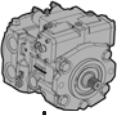

Auxiliary mounting pad

SAE A flanges

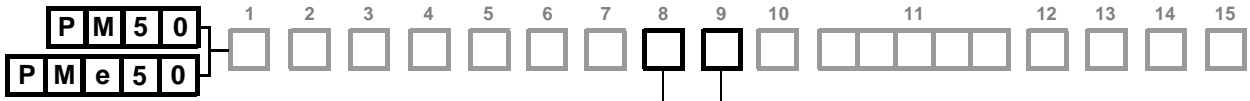

Flange type	Number of teeth	Pitch	Max. torque N.m [in.lbf]	
SAE A	9	5/8" pitch 16/32" DP	80 [708]	A
	11	3/4" pitch 16/32" DP	160 [1 416]	E

- 00** Without charge pump

- 11** With charge pump: 11,0 cm³/rev [0.67 in³/rev]

- 16** With charge pump: 15,8 cm³/rev [0.96 in³/rev]

Splined ANSI B92.1a-1996
Pressure angle 30°
Tolerance class: 5

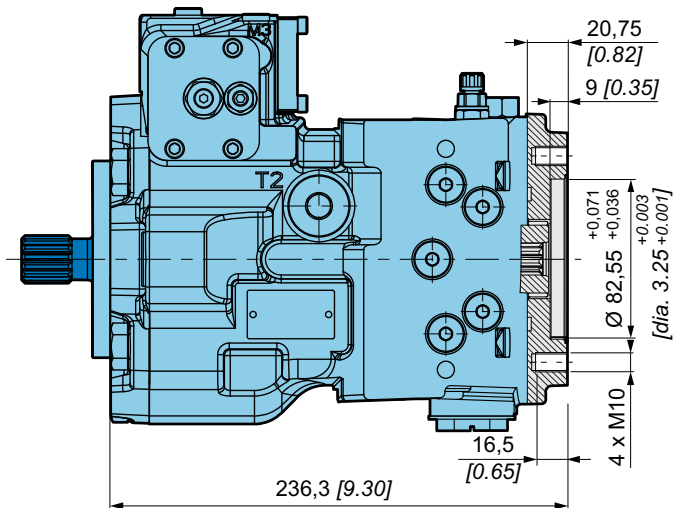
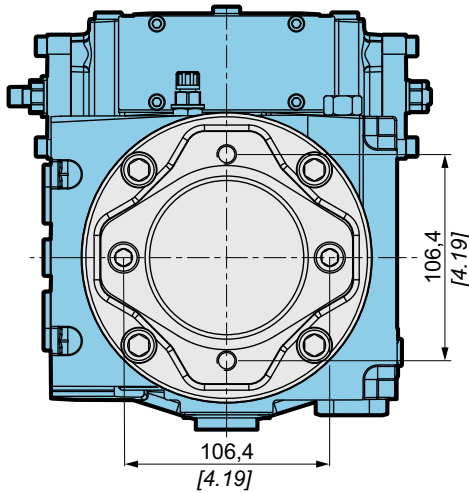

O-ring: OR-1.78-82,27-NBR70
P/N: 24OR2-42



Do not rotate the thru shaft cover.

Model code

Technical specifications

Operating parameters

System parameters

Features

Controls

PMe package

PMe installation

Options

Appendixes

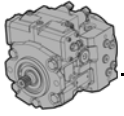

SAE-B and SAE-BB flanges

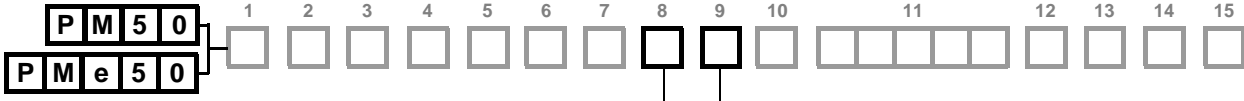

Flange type	Number of teeth	Pitch	Max. torque N.m [in.lbf]	
SAE B	13	7/8" pitch 16/32" DP	220 [1950]	B
SAE BB	15	1" pitch 16/32" DP	360 [3 186]	C

- 00** Without charge pump

- 11** With charge pump: 11,0 cm³/rev [0.67 in³/rev]

- 16** With charge pump: 15,8 cm³/rev [0.96 in³/rev]

Splined ANSI B92.1a-1996
Pressure angle 30°
Tolerance class: 5

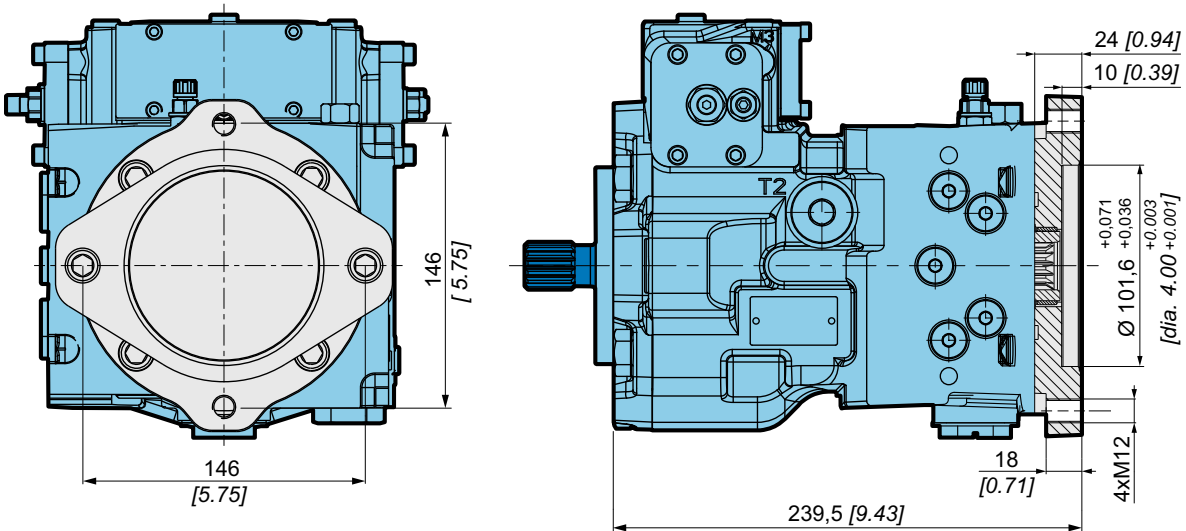

O-ring: OR-1.78-101.32-NBR70
P/N: A47888C



Do not rotate the thru shaft cover.

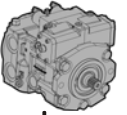

Tandem pumps (only for PM50)

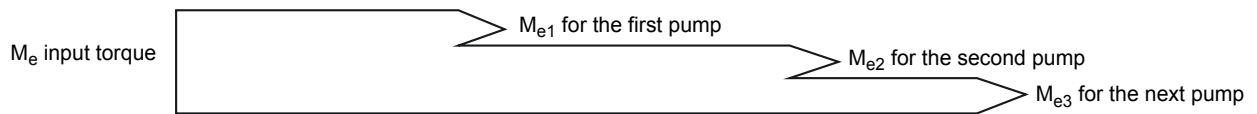
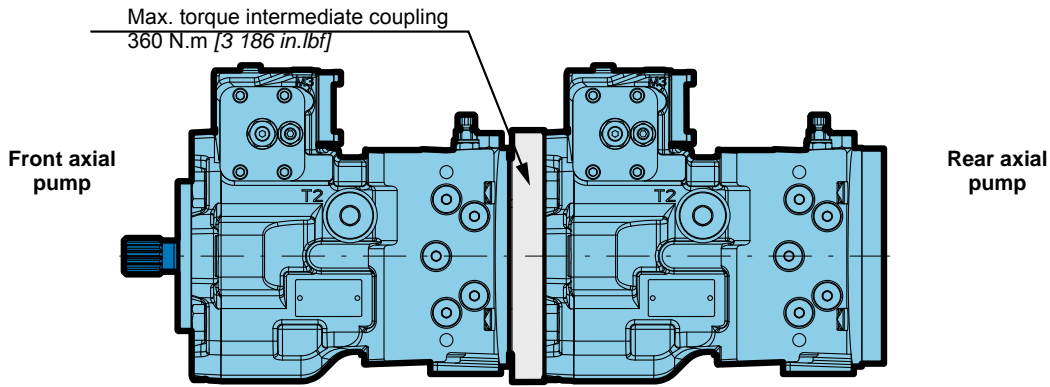

i Torque required by auxiliary pumps is additive. Ensure requirements don't exceed shaft torque ratings.

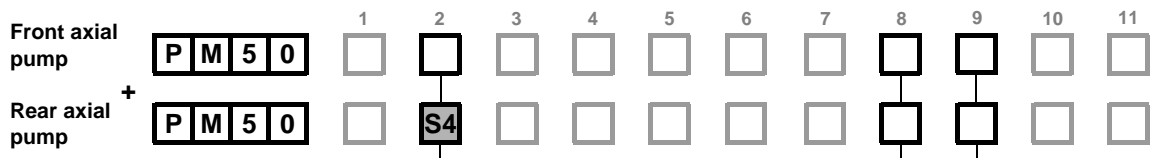

Number of charge pump in the tandem	Axial pump	Mounting flange and shaft	Charge pump	Auxiliary mounting flange	Total axial length mm [inch]			
0 charge pump	Front	SAE BB; 15 teeth	S4	Without	00	Tandem fitting	T	
		SAE B; 14 teeth	S5			Without fitting	S	455,0 [17.91]
	Rear	SAE BB; 15 teeth	S4	Without	00	SAE A; 9 teeth	A	475,8 [18.73]
						SAE A; 11 teeth	E	475,8 [18.73]
						SAE B; 13 teeth	B	479 [18.86]
						SAE BB; 15 teeth	C	479 [18.86]
1 charge pump	Front	SAE BB; 15 teeth	S4	With	11 or 16	Tandem fitting	T	
		SAE B; 14 teeth	S5			Without fitting	S	455,0 [17.91]
	Rear	SAE BB; 15 teeth	S4	Without	00	SAE A; 9 teeth	A	475,8 [18.73]
						SAE A; 11 teeth	E	475,8 [18.73]
						SAE B; 13 teeth	B	479 [18.86]
						SAE BB; 15 teeth	C	479 [18.86]
2 charge pumps	Front	SAE BB; 15 teeth	S4	With	11 or 16	SAE BB; 15 teeth	C	
		SAE B; 14 teeth	S5			Without fitting	S	470 [17.91]
	Rear	SAE BB; 15 teeth	S4	With	11 or 16	SAE A; 9 teeth	A	475,8 [18.73]
						SAE A; 11 teeth	E	475,8 [18.73]
						SAE B; 13 teeth	B	479 [18.86]
						SAE BB; 15 teeth	C	479 [18.86]

i Gear pumps are always delivered flanged on the axial pump. They can not be sold alone.

- Model code
- Technical specifications
- Operating parameters
- System parameters
- Features
- Controls
- PMe package
- PMe installation
- Options
- Appendixes

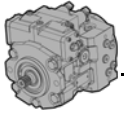

Example of tandem configuration with 1 charge pump (only for PM50)

		1	2	3	4	5	6	7	8	9	10	11
Front axial pump	P	M	5	0		S4					T	
Rear axial pump	P	M	5	0		S4			00	S		

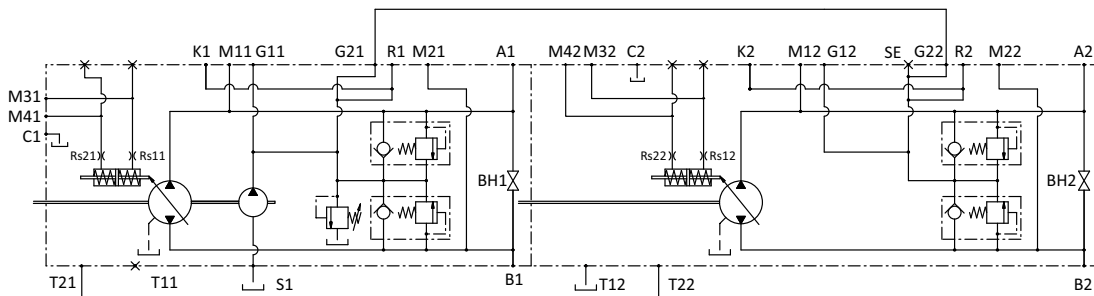
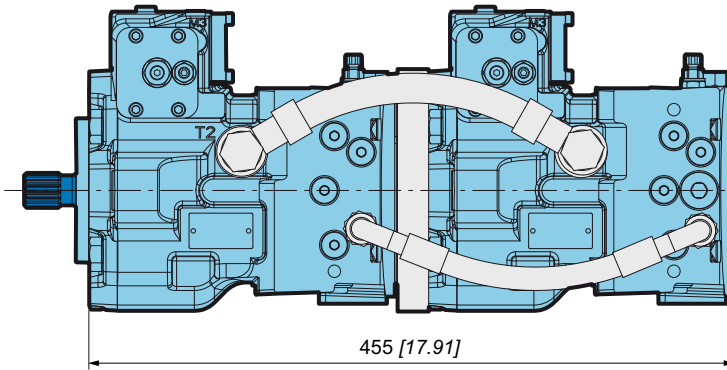

Ports T and G of the first pump must be connected with ports T and G of the second pump.

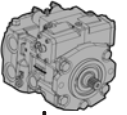

Example of tandem configuration with 2 charge pumps (only for PM50)

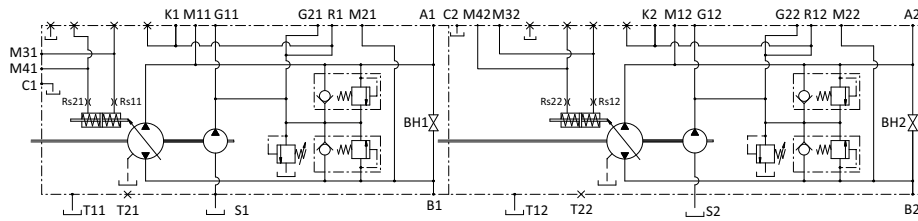
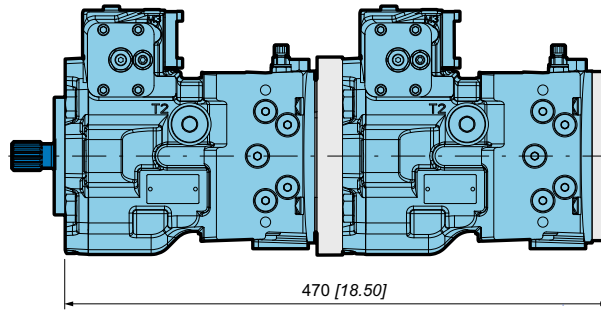
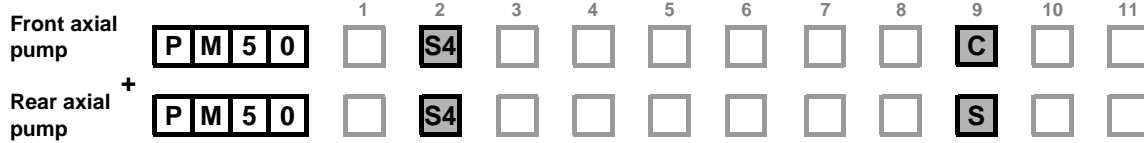

Gear pumps

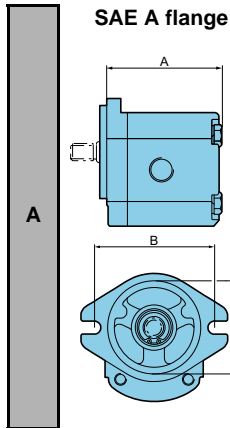

	Displacement cm ³ /rev [cu.in/rev]	Pressure			Dimension			Mass Kg [lb]	Efficiency %
		Continuous max. pressure bar [PSI]	Max. intermittent pressure bar [PSI]	Max. peak pressure bar [PSI]	A mm [in]	B mm [in]	C mm [in]		
04	4,0 [0.24]	250 [3 625]	270 [3 915]	290 [4 205]	93 [3.66]			2,30 [5.07]	
06	6,0 [0.37]	250 [3 625]	270 [3 915]	290 [4 205]	96,3 [3.79]			2,45 [5.40]	
08	8,5 [0.52]	250 [3 625]	270 [3 915]	290 [4 205]	100,5 [3.96]			2,60 [5.73]	
11	11,0 [0.67]	250 [3 625]	270 [3 915]	290 [4 205]	104,6 [4.12]			2,70 [5.95]	
14	14 [0.85]	250 [3 625]	270 [3 915]	290 [4 205]	109,6 [4.31]	106,4 [4.19]	82,5 [3.25]	2,80 [6.17]	95*
17	16,5 [1.00]	230 [3 335]	240 [3 480]	250 [3 625]	113,8 [4.48]			2,95 [6.51]	
20	19,5 [1.19]	210 [3 045]	220 [3 190]	230 [3 335]	118,8 [4.68]			3,10 [6.84]	
23	22,5 [1.37]	190 [2 755]	200 [2 900]	210 [3 045]	123,8 [4.87]			3,25 [7.17]	
26	26 [1.59]	170 [2 465]	180 [2 610]	190 [2 755]	129,6 [5.10]			3,40 [7.50]	

* Value collected during the testing at 1500 rpm



It's possible to provide different gear pump (group 3 with SAE B pad).

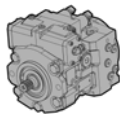

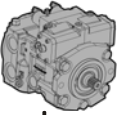

CONTROLS

Mechanical servo control with feedback (only for PM50)

	1	2	3	4	5	6	7	8	9	10	11
P	M	5	0	<input type="checkbox"/>	<input type="checkbox"/>	<input type="checkbox"/>	<input type="checkbox"/>	<input type="checkbox"/>	<input type="checkbox"/>	<input type="checkbox"/>	<input type="checkbox"/>
			A								

Control function	The variation in pump displacement is reached by control lever rotation to adjust hydraulic servo piston position. Control lever range is 40°. Movement of control lever is independent of the pressure and pump speed.
Control regulation	To avoid sudden accelerations and stoppages, two restrictors (Rs1 and Rs2) are inserted between servo control and hydraulic servo piston. They are used to regulate control shifting speed.
Feedback function	The feedback system between swash plate and hydraulic servo piston permit to maintain constant displacement of the pump if the pressure between pump and hydraulic motor changes. The feedback function is reached by a lever that connects the swashplate and the hydraulic servo piston.

Flow rate determination

Rotation	Control	Output	Input
Clockwise (R)	X	A	B
Counter clockwise (L)	X	B	A
	Y	A	B

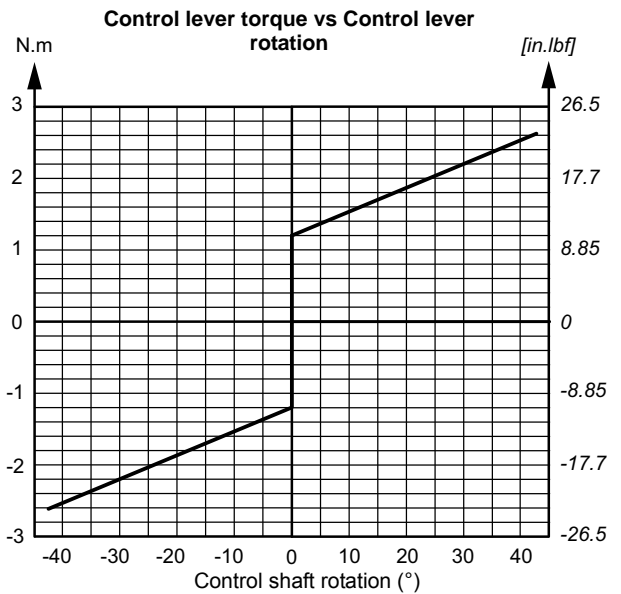
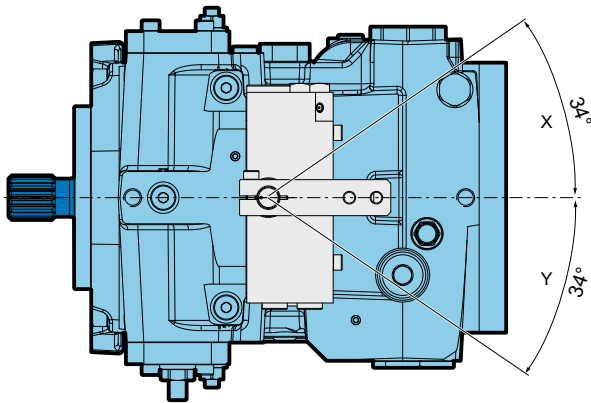
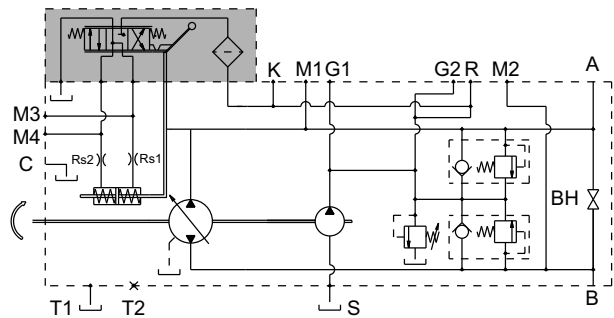

The spring return feature in the control unit is not a safety device.

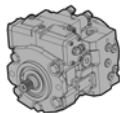

Dimensions with control A

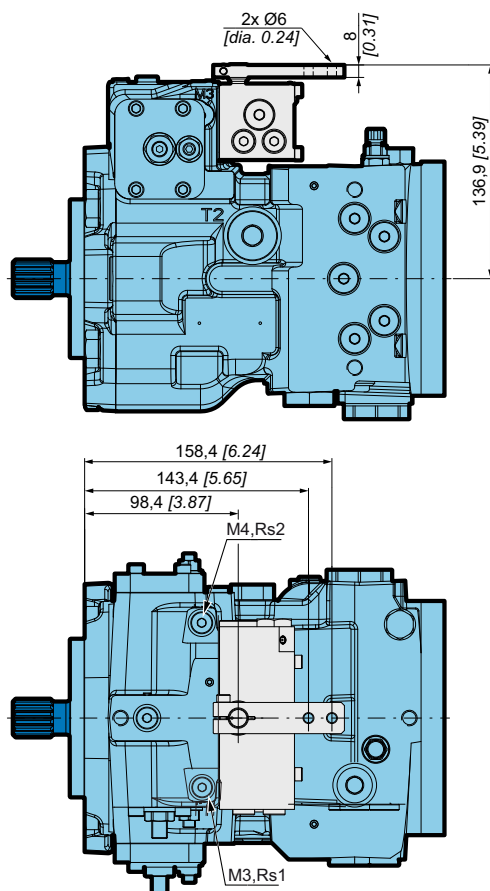

See page 7 for other dimensions
and page 6 for port characteristics.



See option MI page 82 to add neutral position switch.

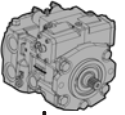

Hydraulic servo control (only for PM50)

1 2 3 4 5 6 7 8 9 10 11
P M 5 0 **S**

Control function	The variation in pump displacement is reached by pressure adjustment on the M3 and M4 servo control ports. These ports are controlled by hydraulic proportional joystick (containing pressure reduction valves). The joystick supply can be obtained by taking pressure from the auxiliary pump (R connection). Basic joystick can be provided upon request.
Control regulation	The servo control response time can be adjusted by two restrictors (Rs1 and Rs2) inserted on the joystick supply line (from 0,6 to 1,2 mm [from 0.02 to 0.05 in]). The servo control operation pressure curve in both control directions goes from 4,5 to 15 bar [from 65 to 218 PSI]. The adjustment curve of the hydraulic control system has to be wider, from 4 to 16 bar [from 58 to 232 PSI].



Other curves can be used in relation to valve plate timing. Contact your Poclain Hydraulics application engineer for further info.



For the selection of the regulation curve (with or without step) of the Joystick contact your Poclain Hydraulics application engineer.

Flow rate determination

Rotation	M3	M4
Clockwise (CW)	A	B
Counter clockwise (CCW)	B	A

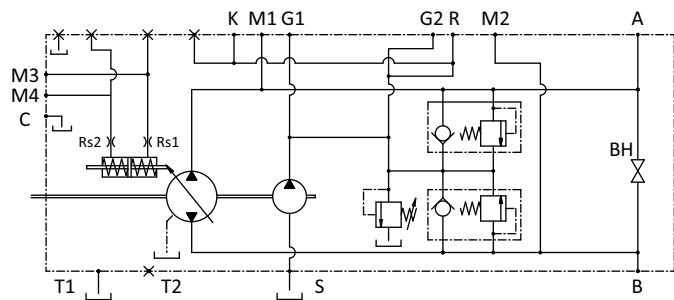

The spring return feature in the control unit is not a safety device.



Hydraulic joystick can be with or without step.



The back pressure of the return line of the joystick and the drive line of the pump has an influence on Servo pressure vs Displacement values.

Servo pressure vs Displacement

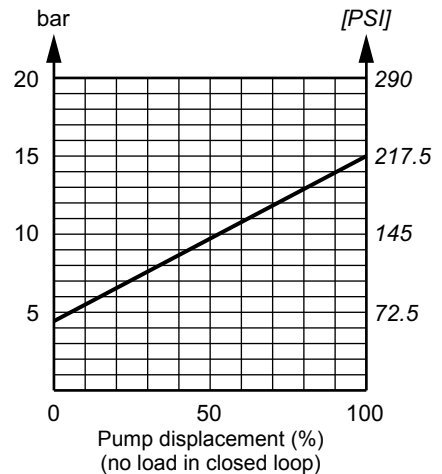

Above graph is just an example that shows the relationship between servo pressure and displacement.

Model code

Technical specifications

Operating parameters

System parameters

Features

Controls

PMe package

PMe installation

Options

Appendix

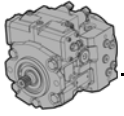

Dimensions with control S

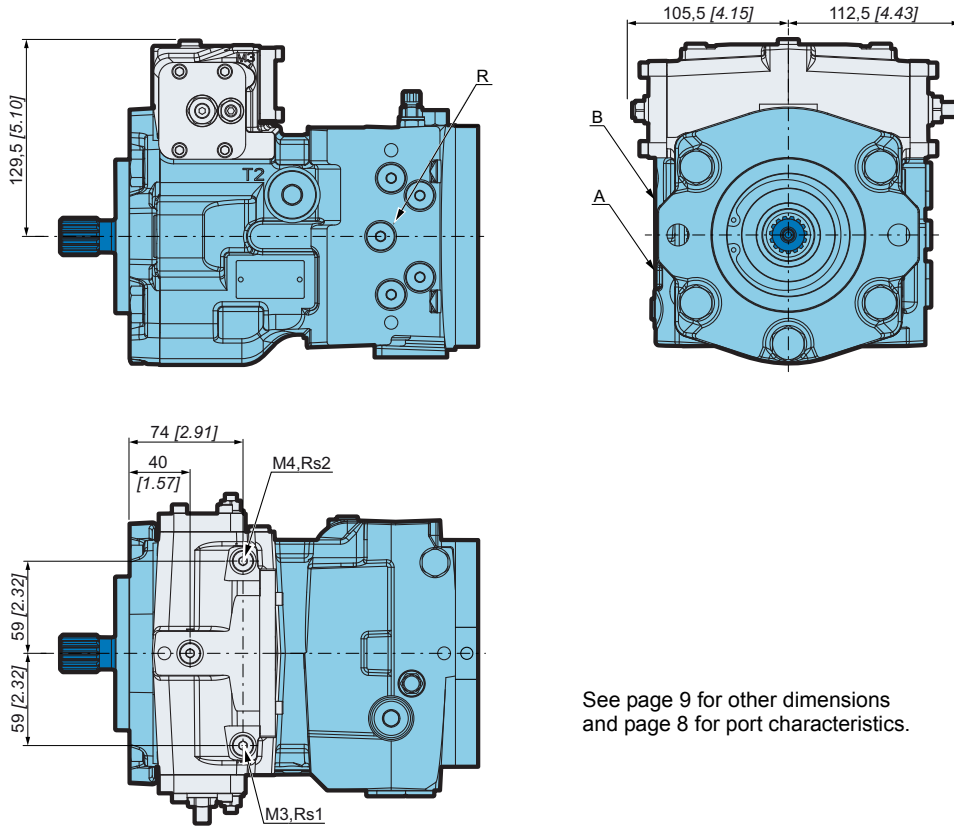

See page 9 for other dimensions and page 8 for port characteristics.

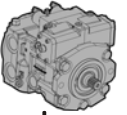

Hydraulic servo control with feedback (only for PM50)

1
 2
 3
 4
 5
 6
 7
 8
 9
 10
 11

P
 M
 5
 0
 T

Control function	The variation in pump displacement is reached by pressure adjustment on the M5 and M6 feedback control ports. These ports are controlled by hydraulic proportional joystick (containing pressure reduction valves). The joystick supply can be obtained by taking pressure from the auxiliary pump (R connection). Basic joystick can be provided upon request
Control regulation	The servo control operation curve in both directions goes from 6 to 15 bar [from 87 to 218 PSI]. The adjustment curve of the hydraulic control system has to be wider, from 5 to 16 bar [from 73 to 232 PSI].
Feedback function	The feedback system between swash plate and hydraulic servo piston permit to maintain constant displacement of the pump if the pressure between pump and hydraulic motor changes. The feedback function is reached by a lever that connects the swashplate and the hydraulic servo piston. To avoid sudden accelerations and stoppages, two restrictors (Rs1 and Rs2) are inserted between the servo control and the hydraulic servo piston.



Contact your Poclain Hydraulics application engineer in case of special needs of the control.

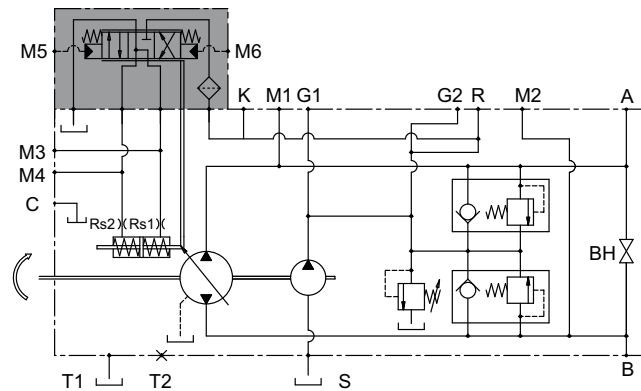

Hydraulic joystick can be with or without step.

Model code

Technical specifications

Operating parameters

System parameters

Features

Controls

PMe package

PMe installation

Options

Appendixes

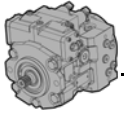

Dimensions with control T

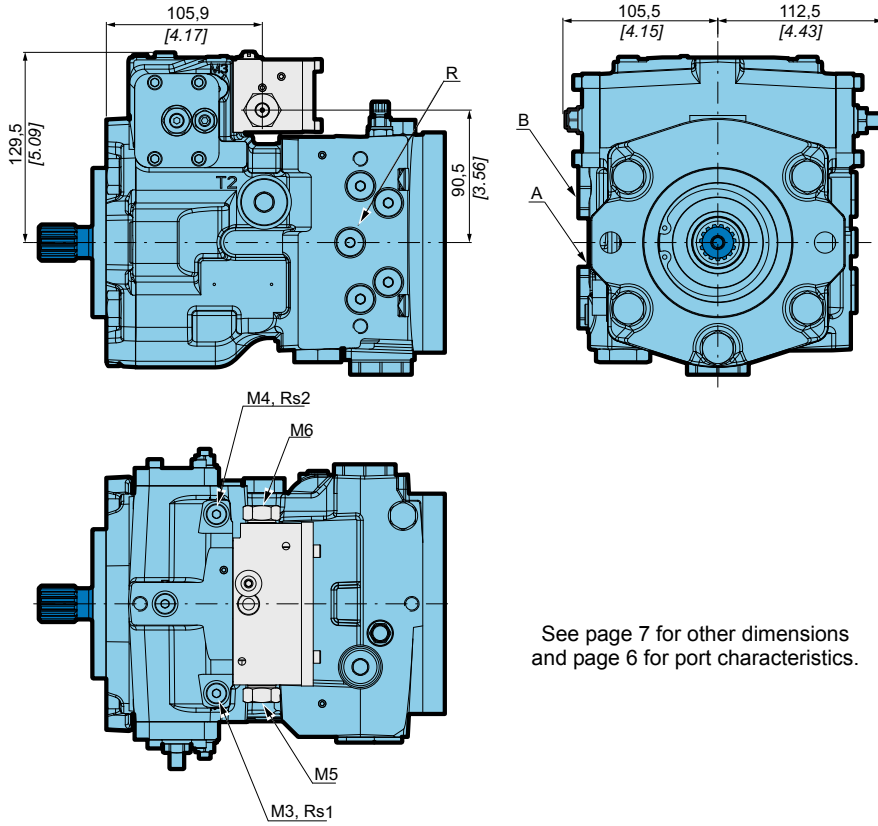

See page 7 for other dimensions
and page 6 for port characteristics.

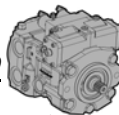

Hydraulic automotive control (only for PM50)

P
M
5
0
1 2 3 4 5 6 7 8 9 10 11

Control function	The variation in pump displacement is reached by continuous electro-hydraulic valve adjustment. The adjustment is precised by pilot pressure controlled by solenoid control. The pilot pressure increases proportionally to the rotation of the pump. The pump displacement increases corresponding to the higher pilot pressure.
Control regulation	In case the engine is overloaded, the rotation rate decreases and the pilot pressure is reduced causing a pump displacement reduction with a corresponding drop in absorbed power.
Inching function	Inching function is reached by reduction of the pilot pressure, independently of the pump rotation speed (see option IC page 79). Consequently the pump displacement is reduced.

Supply voltage

12V	D12
24V	D24

Flow rate determination

Rotation	Pressure	Output	Input
Clockwise (R)	EV1	B	A
	EV2	A	B
Counter clockwise (L)	EV1	A	B
	EV2	B	A

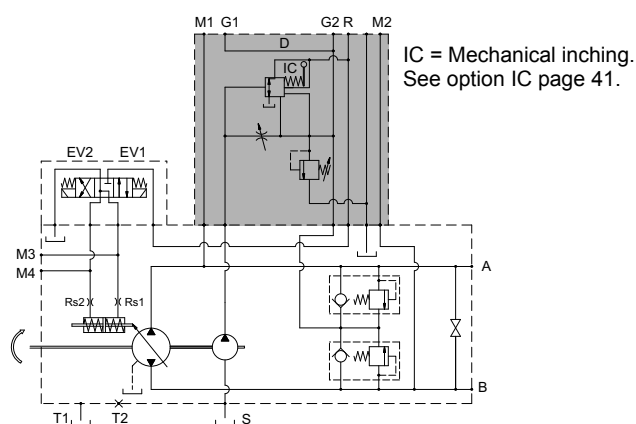

For automotive valve setting are necessary power and torque curve of the engine.

- Model code
- Technical specifications
- Operating parameters
- System parameters
- Features
- Controls
- PMe package
- PMe installation
- Options
- Appendixes

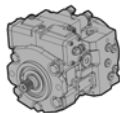

Dimensions with control D and mechanical inching

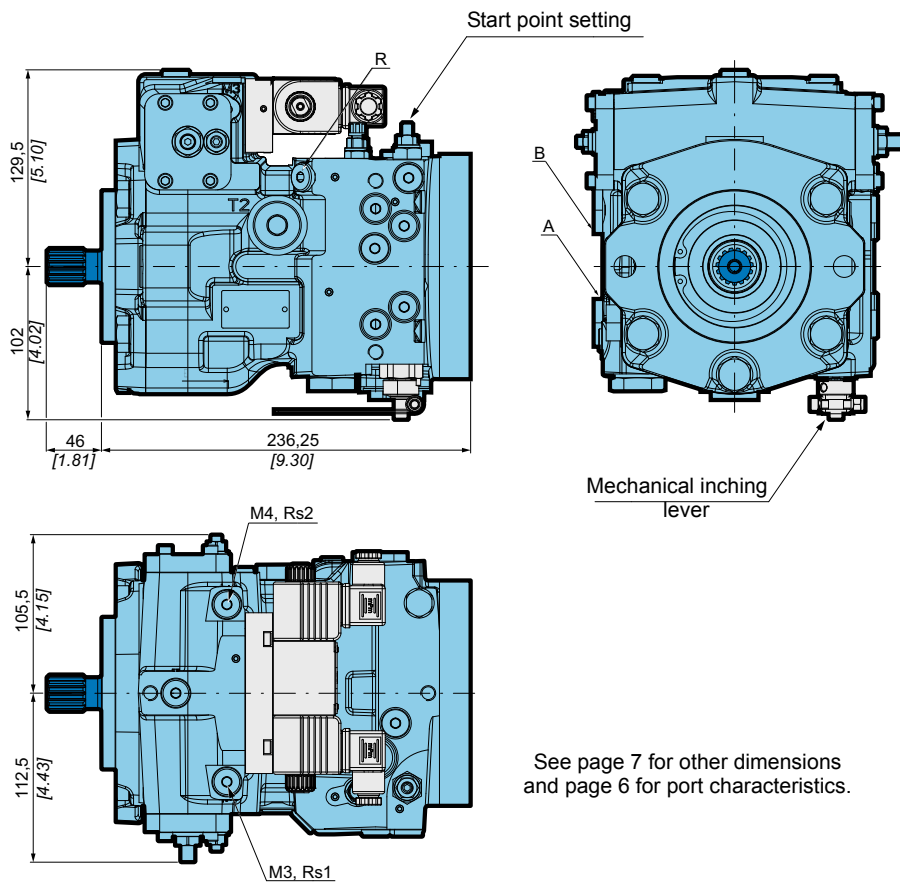

IC rotation angle controls pump destroke. Angle of regulation is 25°.

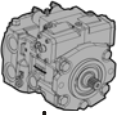

Electrical on-off servo control (only for PM50)

Control with return spring

1
 2
 3
 4
 5
 6
 7
 8
 9
 10
 11

Control function	The change in pump displacement is reached by activation of an ON-OFF electrovalve with closed CETOP 2 connection. If the electrovalve motion is stopped, the pump goes back to neutral position due to the hydraulic servo piston return springs.
Control regulation	The displacement reached is defined by the starting time of the electrovalve and by diameter of restrictors (Rs1 and Rs2) inserted between the electrovalve and the hydraulic servo piston. The pump can be supplied either without electrovalve (B00) or with electrovalve (B12 / B24).

Supply voltage	
Without	B00
12V	B12
24V	B24

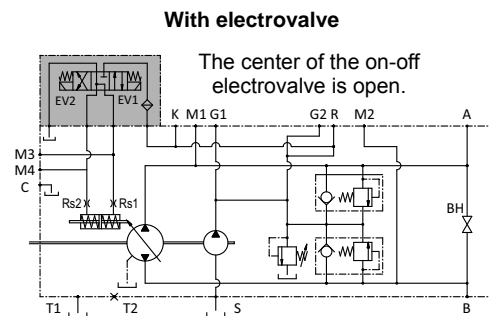
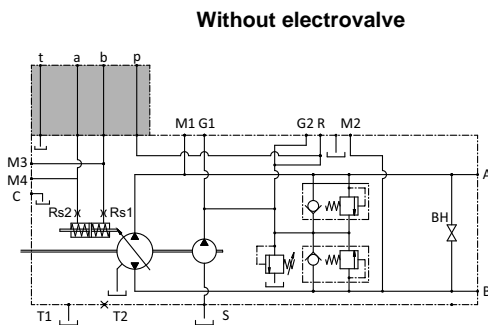

Control without return spring

1
 2
 3
 4
 5
 6
 7
 8
 9
 10
 11

Control function	The change in pump displacement is reached by activation of an ON-OFF electrovalve with closed CETOP 2 connection. The hydraulic servo piston is without return springs, the pump setting at certain displacement is defined by closed center of electrovalve.
Control regulation	The displacement reached is defined by the starting time of the electrovalve and by diameter of restrictors (Rs1 and Rs2) inserted between the electrovalve and the hydraulic servo piston. The pump can be supplied either without electrovalve (C00) or with electrovalve (C12 / C24).

Supply voltage	
Without	C00
12V	C12
24V	C24

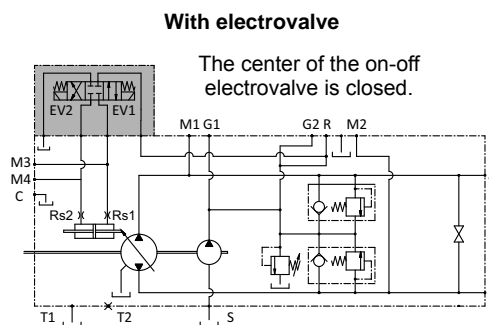
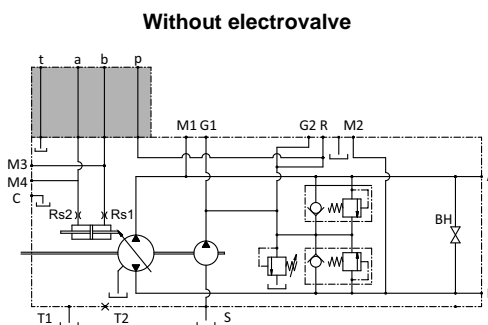

Flow rate determination

Rotation	EV1	EV2
Clockwise (CW)	A	B
Counter clockwise (CCW)	B	A



The spring return feature in the control unit is not a safety device.

Model code

Technical specifications

Operating parameters

System parameters

Features

Controls

PMe package

PMe installation

Options

Appendixes

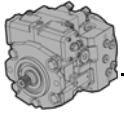

Dimensions with control B or C

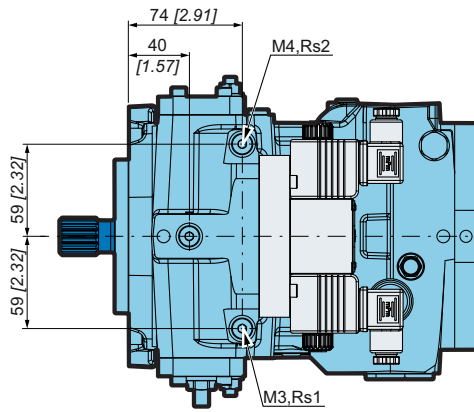
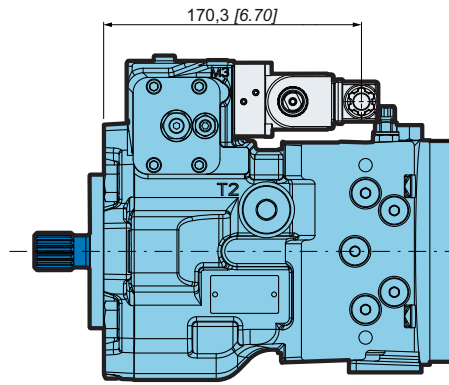
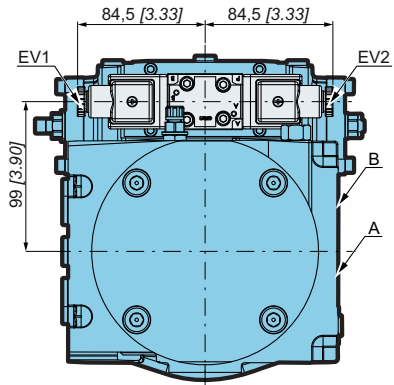

See page 7 for other dimensions and page 6 for port characteristics.

Solenoids specification

Operating voltage	12 VDC ± 10%	24 VDC ± 10%
Resistance at 20°C [68°F]	5,3 Ω ± 7%	21,2 Ω ± 7%
Connector type	DIN 43650	
Nominal power	27 W	
Protection	IP65	
Mass	0,215 kg [0.47 lb]	

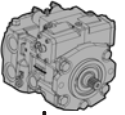

Electro-proportional servo control (for PM/PMe50)



Control function	The variation in pump displacement is reached by current adjustment applied to proportional valve coils. The coils then adjust the pressure of the servo control connected to the hydraulic servo piston. The flow rate direction depends on activated coil.
Control regulation	The reaction time can be controlled by ramps installed on the card and by restrictors (Rs1 and Rs2) positioned between the electrovalves and the hydraulic servo piston.
Automotive function	Electro-proportional servo control combined with ECU unit and appropriate software can be used for Higher performances Automotive control.

Supply voltage

12V	P12
24V	P24

Flow rate determination

Rotation	EV1	EV2
Clockwise (CW)	A	B
Counter clockwise (CCW)	B	A



Valve plate timing and regulation curve of proportional valve influence the flow. Contact your Poclain Hydraulics application engineer for further info.



The current must not exceed 1500 mA under 12V and 800 mA under 24V.



The spring feature in the control unit is not a safety device.

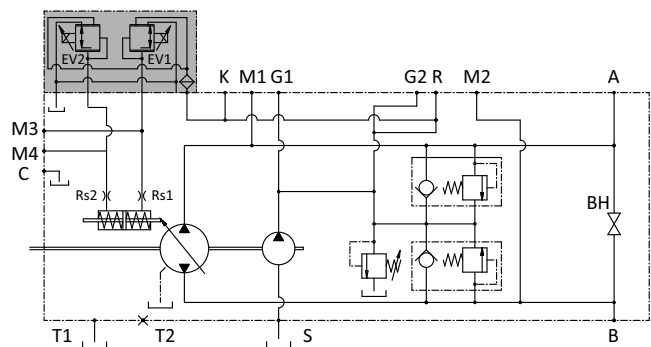

Electrovalve current vs Displacement

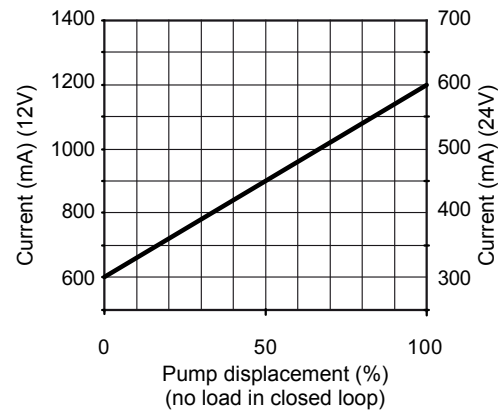

Model code

Technical specifications

Operating parameters

System parameters

Features

Controls

PMe package

PMe installation

Options

Appendixes

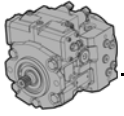

Dimensions with control P

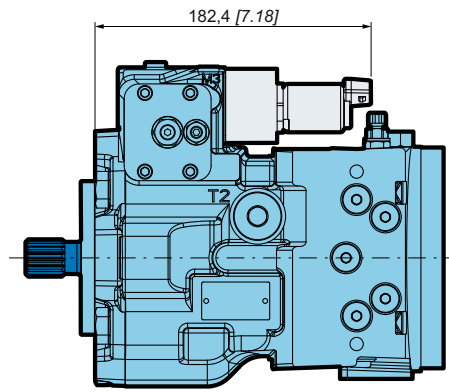
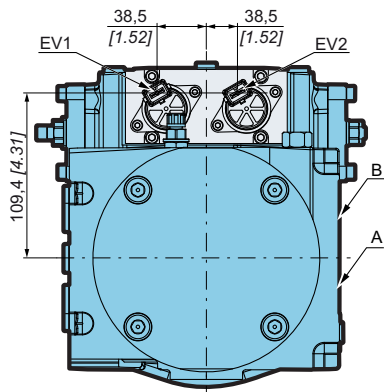

See page 9 for other dimensions and page 8 for port characteristics.

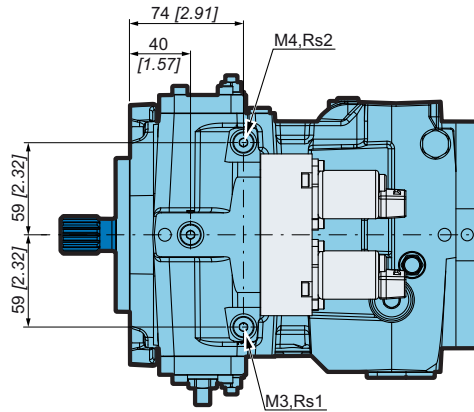

Solenoids specification		
Operating voltage	12 VDC	24 VDC
Current	1500 mA	750 mA
Resistance at 20°C [68°F]	5,3 Ω ± 5%	21,2 Ω ± 5%
Connector type	AMP Junior Timer, Deutsch DT04-2P	
Protection	IP6K6 / IPX9K	

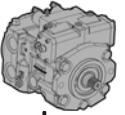

Electro-proportional servo control with feedback (for PM/PMe50)



Control function	The variation in pump displacement is reached by current adjustment applied to electro-proportional coils. The coils then adjust the pressure of the servo control. The flow rate direction depends on activated coil.
Control regulation	The reaction time can be controlled by ramps installed on the card and by restrictors (Rs1 and Rs2) inserted between the servo control and the hydraulic servo piston.
Feedback function	The feedback function is reached by a lever that connects the swashplate and the hydraulic servo piston. To avoid sudden accelerations and stoppages, two restrictors (Rs1 and Rs2) are inserted between the servo control and the hydraulic servo piston.

Supply voltage	12V	Q12
	24V	Q24

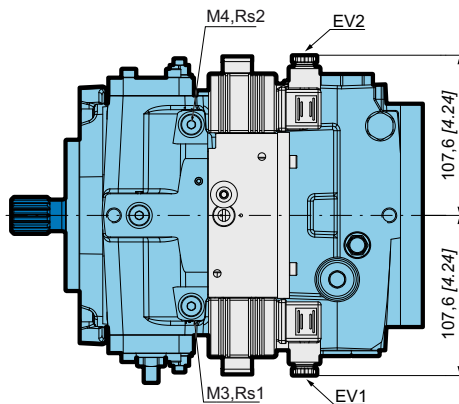
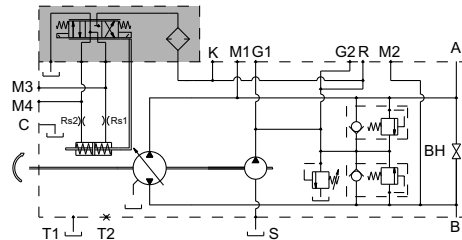
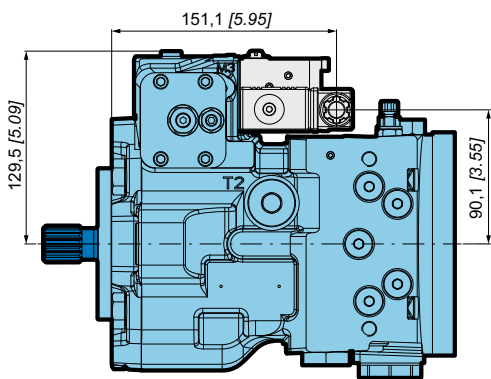

Electrovalve current vs Displacement

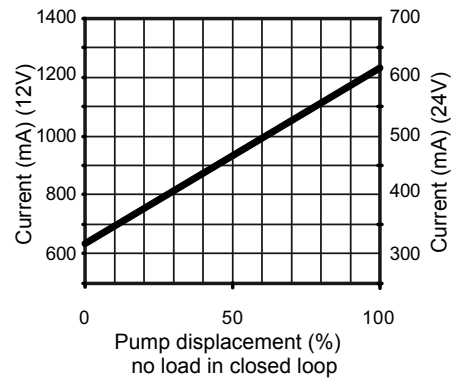

See page 9 for other dimensions and page 8 for port characteristics.

Solenoids specification		
Operating voltage	12 VDC	24 VDC
Current	1500 mA	750 mA
Resistance at 20°C [68°F]	5,3 Ω ± 5%	21,2 Ω ± 5%
Connector type	Hirschman DIN 43650 Deutsch DT04-2P AMP Junior Timer (standard for PMe)	
Protection	IP6K6 / IPX9K	

- Model code
- Technical specifications
- Operating parameters
- System parameters
- Features
- Controls
- PMe package
- PMe installation
- Options
- Appendixes

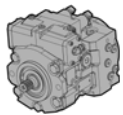

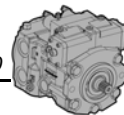

PME PACKAGE



Acronym	Definition
SD-CT-30	Electronic control unit
CAN	Control Area Network (high speed serial communication bus)
EMC	Electromagnetic compatibility
I/O	Input/Output
J1939	Standard SAE CAN - protocol for agricultural vehicle
SD	Poclain Hydraulics transmission controller
TP	Travel pedal
LimpMode	Minimum drive while failure

Software packages	
A	Standard package
B	Standard + Driving packages
C	Standard + Protection packages
D	Standard + Driving + Protection packages
E	CAN slave

List of functions

Standard package

- Start-up check ⁽¹⁾
- Command device (travel pedal, joystick or DA-Like) ^{(1) (2)}
- CAN slave management
- Proportional engine control
- Fixed engine control (adjustable by Display 1.5")
- Driver presence
- Brake lights
- Braking/Inching management
- Dagnostic (by failure lamp or Display 1.5") ^{(1) (3)}

Driving package

- Anti-stall
- Hill start
- CAN broadcasting
- Speed control loop (mode deactivable by Display 1.5") option: with 2 wheel speed sensors
- Mixed (Automotive or Fixed) engine control (change by Display 1.5")
- Shifting

Protection package

- Overpressure protection
- Overpower protection
- Engine overspeed protection
- Temperature protection

CAN slave

(1) Functions activated by default.
 (2) By default, command device selected in the model code is 1 signal device with F/R direction switches (in case of travel pedal).
 (3) By default, diagnostic is done with failure lamp.

- Model code
- Technical specifications
- Operating parameters
- System parameters
- Features
- Controls
- PMe package
- PMe installation
- Options
- Appendixes

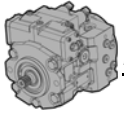

Anti-stall

Aim of the function

Prevents the engine from stalling.

Description

SD-CT-30 monitors engine speed.

- When engine speed is lower than expected, SD-CT-30 reduces pump displacement, thus torque needed by pump.
- When engine speed is back to its expected value, SD-CT-30 gently drives the pump to recover driver command.

Ergonomics

Driver uses standard joystick or pedal to require machine to move.

Inputs/Outputs

- CAN Bus

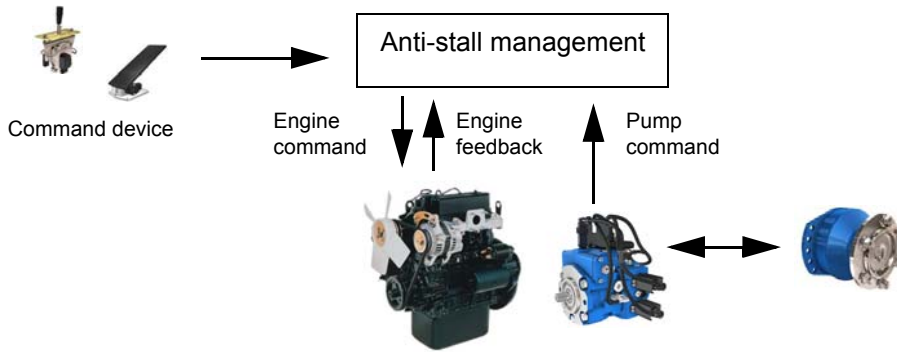

Brake lights

Aim of the function

Switches on and off the brake lights.

Description

SD-CT-30 monitors machine acceleration and deceleration and - if appropriate - the braking command. When deceleration overpasses defined level or when driver braking request is detected, SD-CT-30 switches on the brake lights.

SD-CT-30 switches off the brake lights when deceleration is lower than defined level and when there is no more driver braking request.

Ergonomics

Driver uses standard joystick, pedal or DA-like, and if present the braking pedal, to drive the machine. When appropriate, SD-CT-30 switches on the brake lights.

Inputs/Outputs

- Driver command interface: Joystick, pedal or DA-like, brake pedal input if present.
- 1 digital output to drive brake lights relay.

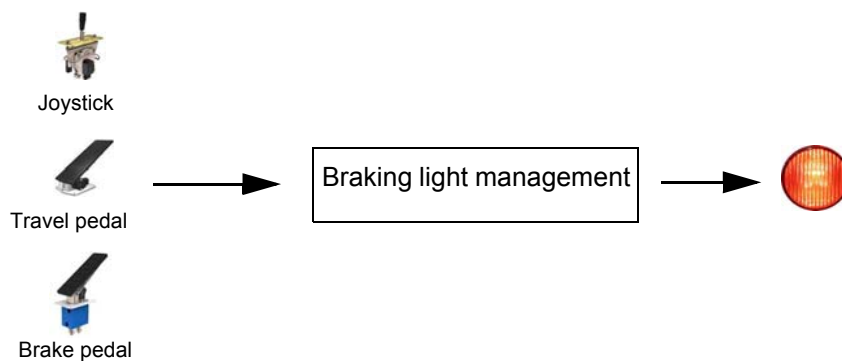

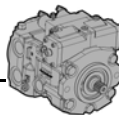

Driver presence

Aim of the function

Check that driver is present. Stop the machine if needed.

Description

SD-CT-30 checks that driver is present thanks to a seat switch.
When SD-CT-30 detects that driver is not on the seat, it stops the machine.

Ergonomics

When driver leaves his seat, machine stops accordingly to a parameter defined ramp. If driver is back before machine has stopped, to avoid machine acceleration, brake security loop is engaged. The operator will first have to bring the joystick or travel pedal back to the position matching the current vehicle speed to recover the full control of the speed.

Inputs/Outputs

- 1 digital input for reading the seat switch.

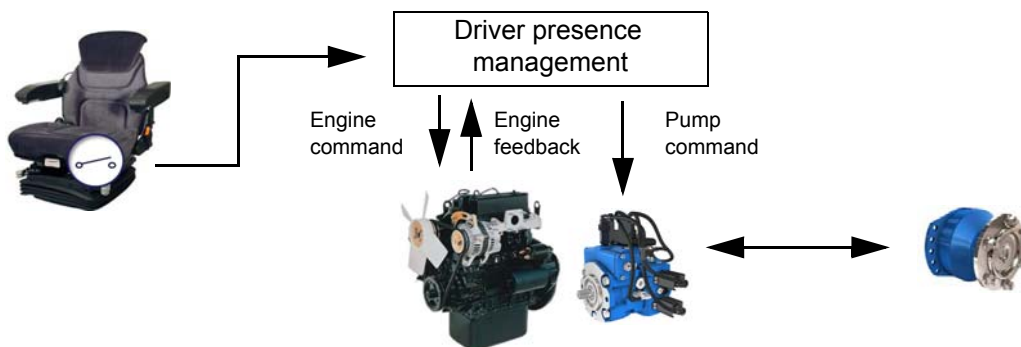

Temperature protection

Aim of the function

Protect the hydrostatic transmission against over temperature to preserve components lifetime.

Description

SD-CT-30 monitors temperature in transmission.
When temperature overpass a limit defined with a parameter, SD-CT-30 reduces machine speed to recover acceptable temperature.
Machine speed reduction is managed thanks to:
 • A reduction of the pump displacement.
 • A reduction of the engine command.
 The reduction ratios values are set by parameters.

Ergonomics

When system recovers acceptable temperature, reduction of machine speed is not more needed.
To avoid machine acceleration a brake security loop is engaged. The operator will first have to bring the joystick or travel pedal back to the position matching the current vehicle speed to recover the full control of the speed.

Inputs/Outputs

- 1 analog input to read temperature sensor.

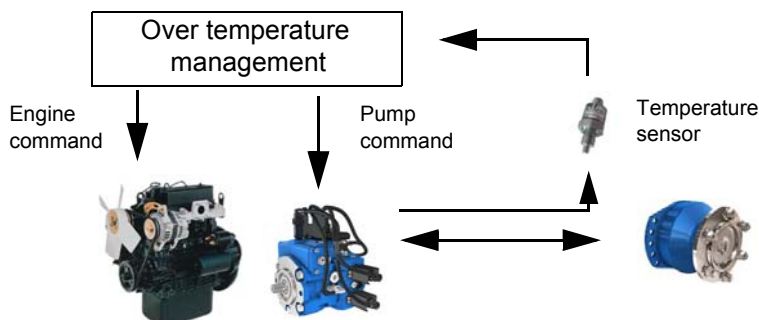

Model code

Technical specifications

Operating parameters

System parameters

Features

Controls

PM package

PM installation

Options

Appendixes

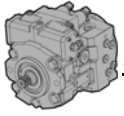

Over pressure protection

Aim of the function

Check that driver is present. Stop the machine if needed.

Description

SD-CT-30 monitors pressure delivered to the transmission.

When pressure overpass the limit defined with a parameter, SD-CT-30 reduces pump displacement to recover acceptable pressure. It works in the same way as hydraulic flow cancellation (Ipor valve).

Inputs/Outputs

- 1 analog input to read the pressure sensor in the hydraulic circuit.
- 1 analog input to read the pressure sensor on reverse line of the hydraulic circuit.

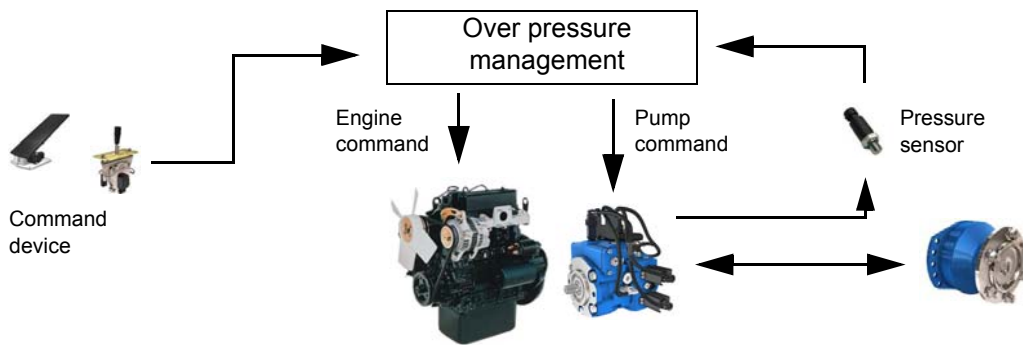

Over power protection

Aim of the function

Protect the hydrostatic transmission against power.

Description

SD-CT-30 monitors pressure and pump speed to compute power delivered to the transmission.

When power overpass the limit defined with a parameter, SD-CT-30 reduces pump displacement to recover acceptable power.

In case of multiple motors displacement configurations, one limit will be defined for each motors displacement with parameters. Over power protection is active in forward and reverse: Two pressure sensors and one engine/pump speed sensor are needed.

Inputs/Outputs

- 1 analog input to read the pressure sensor in the hydraulic circuit.
- 1 analog input to read the pressure sensor on reverse line of the hydraulic circuit.
- CAN Bus or 1 frequency input for pump speed sensor.

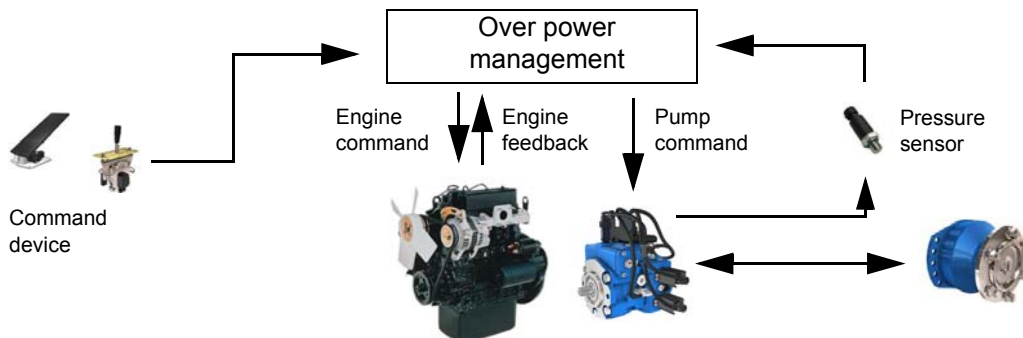

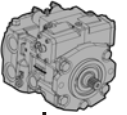

Engine over speed protection

Aim of the function

Protect the engine against overspeed.

Description

SD-CT-30 monitors motor/pump speed.

When engine speed overpass a limit defined with a parameter, SD-CT-30 will limit hydrostatic deceleration to recover acceptable engine speed.

Ergonomics

According to engine speed, ramp of deceleration will be adjusted (time to decelerate is increased) to limit hydrostatic deceleration. Deceleration will be automatically adjusted to the engine braking performances whatever is the slope or the load of the machine. To ensure that the driver will be able to stop the machine, a braking device is mandatory (braking/inching or combined braking).

Inputs/Outputs

- CAN Bus or 1 frequency input for pump speed sensor.
- 1 analog input for braking pressure sensor or braking pedal sensor.

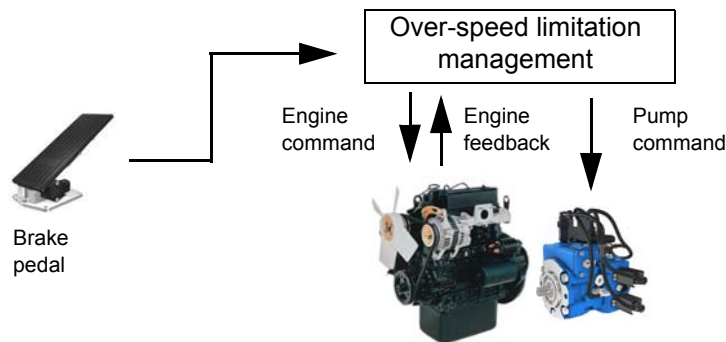

Diagnostic

Aim of the function

Give driver feedback on transmission status.

Description

SD-CT-30 detects errors on the system and informs the user.

Ergonomics

- Two configurations:
- | | |
|---------------|--|
| Failure lamp: | • Blinking in case of error. |
| Display: | • Displays error code and cause. |
| | • Displays transmission information (speed, power, ...). |

Inputs/Outputs

- 1 digital output for failure lamp.
- CAN bus for display.

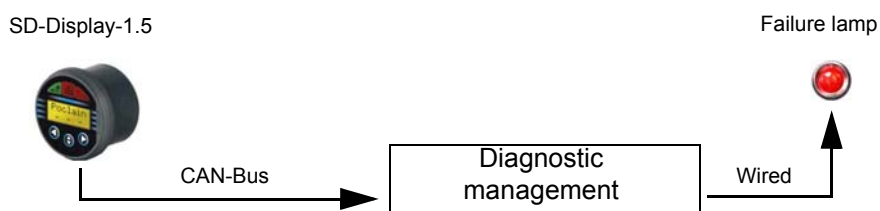

Model code

Technical specifications

Operating parameters

System parameters

Features

Controls

PM package

PM installation

Options

Appendixes

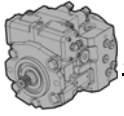

Command device

Aim of the function

Define user ergonomics.

Ergonomics

- Travel pedal (1 signal or 2 signals for redundancy) associated with forward/reverse direction switches or forward/neutral/reverse direction switches (for redundancy).

Possibility to select: • Joystick (1 signal or 2 signals for redundancy).

- DA-like (pump speed defines pump displacement). A braking is mandatory to ensure deceleration if engine stays at high speed.

- CAN Joystick (messages come from the CAN bus as BJM1, BJM2 or BJM3)

Inputs/Outputs

Joystick: • 1 analog input to read the joystick or 2 analog inputs for redundancy. Redundant signal is not compatible with 2 wheel speed sensors option.

- 1 digital input for joystick neutral switch.

Travel pedal: • 1 analog input to read the travel pedal or 2 analog inputs for redundancy. Redundant signal is not compatible with 2 wheel speed sensors option.

- 2 digital inputs for forward/reverse or 3 digital inputs for forward/neutral/reverse.

DA-like: • 1 frequency input for pump speed sensor.

- 2 digital inputs for forward/reverse or 3 digital inputs for forward/neutral/reverse.

CAN Joystick: • Messages come from the CAN bus: BJM1 or BJM2 or BJM3.



See page 77 for “CAN messages from command device option” info.

Usage:

After setting there will be the same behaviour as with “standard analog” Joystick. The machine speed is proportional to the position of the joystick. The direction is set following joystick position.

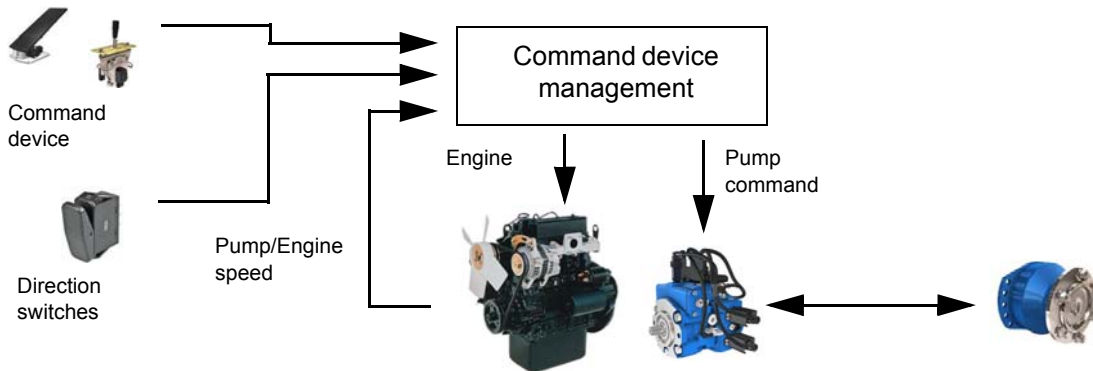

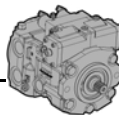

Start-up check

Aim of the function

Ensure that all conditions are valid before making machine move after a powering up.

Ergonomics

Ensures that after SD-CT-30 powering up, embedded software checks SD-CT-30 supply voltage, internal supply voltage, command device, direction switches, pump feedback and parameters values (all at the same time).

Ensures that after SD-CT-30 powering up, command device is seen at 0% and the direction switches are in neutral (all at the same time).

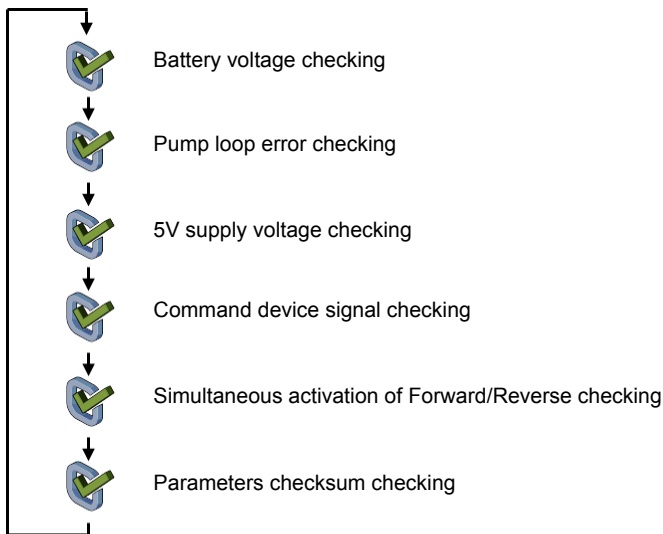

Check of battery voltage

An error occurs if battery voltage is below 9V or above 30V.

Check of 5V supply

An error occurs if the 5V supply provided by the SD-CT-30 is below 4.8V or above 5.2V. The machine stops.

Check Travel pedal or Joystick pedal

An error occurs if the signal from Travel Pedal or Joystick is below 0.25V or above 4.75V. The machine stops.

Simultaneous activation of Forward, Neutral and Reverse switches

These actions are done when two switches (or more) are in the same state:

- Deceleration of machine according ramp.
- Error activation on direction switches

Check of parameters checksum

An error occurs in case of parameter checksum or calibration value checksum. Then machine stay at stop.

Model code

Technical specifications

Operating parameters

System parameters

Features

Controls

PMe package

PMe installation

Options

Appendixes

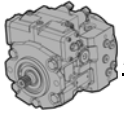

Shifting

Aim of the function

Provide automatic motors displacement change with continuous machine speed increase.



It's highly recommended to select the "00" in selection 4 when shifting functions are activated.

Description

SmartDrive manages pump displacement. When machine reaches maximum speed with actual motor displacement configuration, motors displacement is changed to next defined configuration. Pump displacement is managed accordingly to provide continuous machine speed increase.

Configurations of motors displacement are defined by parameters.

Ergonomics

Motor shifting is automatically managed, no action from driver needed.

Inputs/Outputs

2 digital outputs

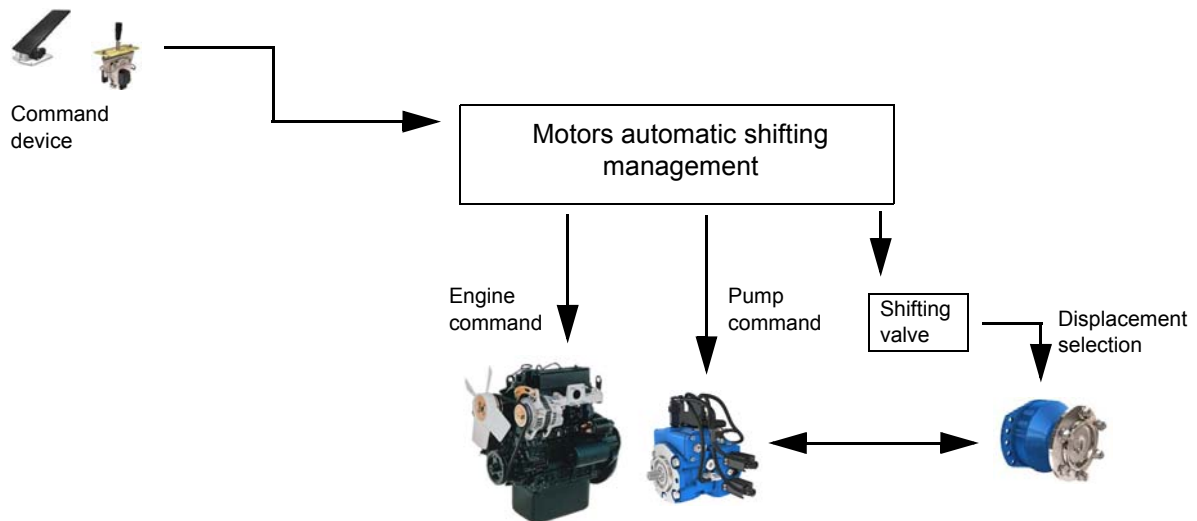

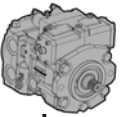

Hill start

Aim of the function

Prevent any rollback when starting in a slope.

Description

SD-CT-30 makes a jump on pump displacement to compensate leakages due to slope.

Ergonomics

To activate hill start, driver must apply the park brake, provide a command device and then remove park brake.

Inputs/Outputs

- 1 analog input for Travel pedal or Joystick.
- 1 digital input for the park brake.

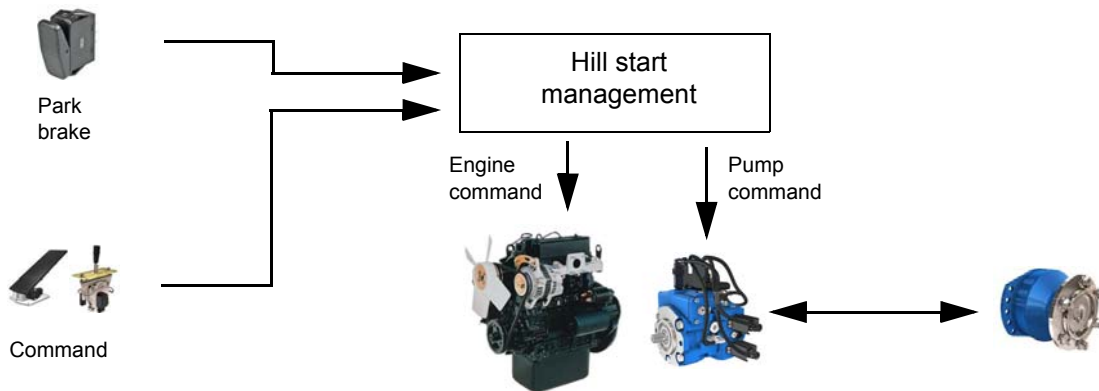

Proportional engine control

Aim of the function

Drive engine speed proportionally to the command device.

Description

Engine is controlled from minimum to maximum speed (parameters) proportionally to command device position.

Ergonomics

Driver uses command device to manage pump displacement and engine speed simultaneously.

Inputs/Outputs

- CAN bus for engine (J1939 protocol).
- Command device: joystick or pedal.

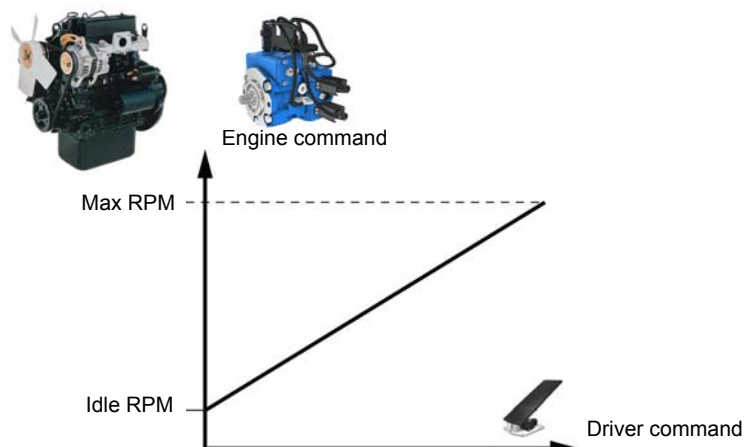

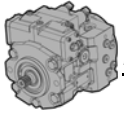

Fixed engine control

Aim of the function

Machine translation is managed with fixed engine speed.

Description

When driver requests the machine to move, SD-CT-30 drives the engine from idle speed to fixed speed. SD-CT-30 adjust machine speed with pump displacement only. After machine stops, SD-CT-30 waits for a parameter defined delay, then drives the engine speed to its idle speed.

Ergonomics

- Driver uses standard joystick or pedal to require machine to move.
- Driver uses a display to set the desired speed for fixed engine control.

Inputs/Outputs

- Command device: joystick or pedal.
- CAN bus for engine (J1939 protocol).
- CAN bus for display.

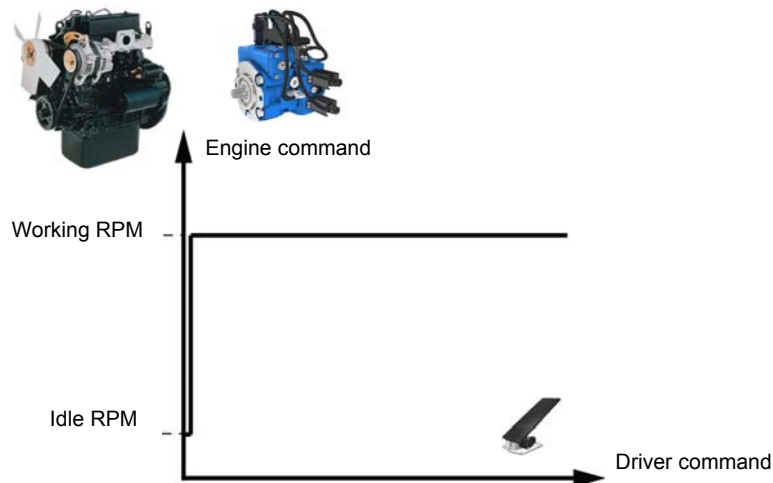

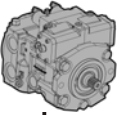

Mixed engine control

Aim of the function

Possibility for driver to select fixed engine control or a proportional engine control.

Description

• Fixed engine control: when driver requests the machine to move, SD-CT-30 drives the engine from idle speed to fixed speed. SD-CT-30 adjusts machine speed with pump displacement only. After machine stops, SD-CT-30 waits for a parameter defined delay, then drives the engine speed to its idle speed.

• Proportional engine control: engine is controlled from minimum to maximum speed (parameters) proportionally to command device position.

Ergonomics

Driver uses display to select between fixed engine control and proportional engine control.

- For proportional engine control: driver uses command device to set machine and engine speed simultaneously.
- For fixed engine control: driver uses standard joystick or pedal to require machine to move and uses a display to set the desired speed.

Inputs/Outputs

- Command device. joystick or pedal.
- CAN bus for engine (J1939 protocol).
- CAN bus for display.

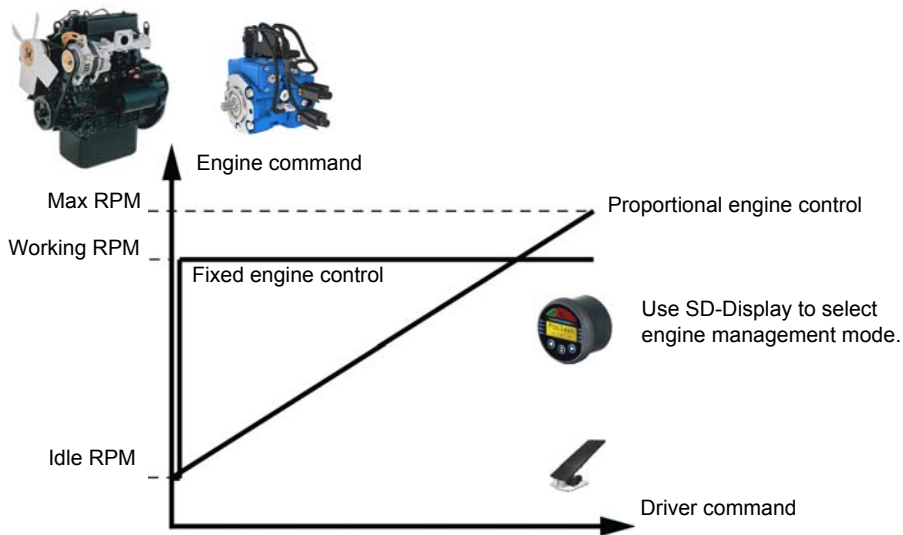

Model code

Technical specifications

Operating parameters

System parameters

Features

Controls

PMe package

PMe installation

Options

Appendixes

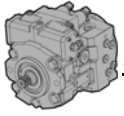

CAN broadcasting

Aim of the function

Send transmission information through CAN bus for driver display and diagnostic purpose.

Description

Send transmission information accordingly to J1939:	Pump command
	Pump flow
	Pump speed
	Driver command
	Brake command
	Inching command
	High pressure A
	High pressure B
	Machine speed
	Mode
	Direction
	Power
	Over power protection status
	Over pressure protectin status
	Anti-stall status
	Engine overspeed status
	Speed control loop status
	Temperature protection status
	Error codes

Inputs/Outputs

- CAN bus (J1939 protocol).

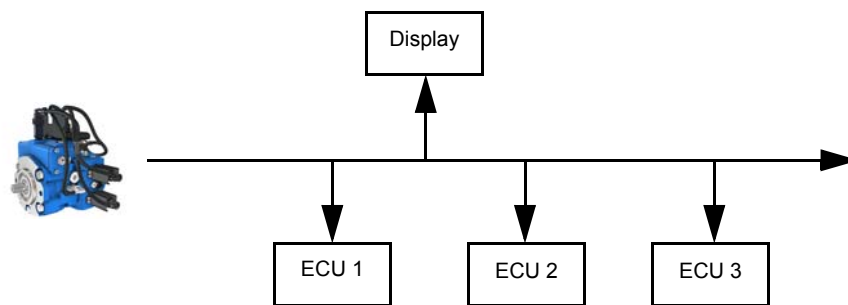

See page 80 for "CAN Bus J1939 standard" info.

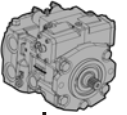

Braking/Inching management

Aim of the function

- Provide hydrostatic braking according to driver request (braking function).
- Provide inching, reduced machine speed, according to driver request (inching function).

Description

- Braking: SD-CT-30 manages hydrostatic braking (m/s^2) proportionally to braking/inching pedal position.
 - Inching: SD-CT-30 manages requested machine speed thanks to: $command\ device\ position \times (1 - braking/inching\ pedal\ position)$.
- First part of pedal range is used for inching and second part for braking. Pedal position to switch from inching to braking is adjustable by parameter.

Ergonomics

- When using braking, machine decelerates until stop. When releasing braking/inching pedal before machine stop, the driver will first have to bring the joystick or travel pedal back to the position matching the current vehicle speed to recover the full control of the speed.
- When using inching, machine speed is reduced according to braking/inching pedal position, following standard deceleration ramp. When inching is released, machine recovers original speed following standard acceleration ramp.

Inputs/Outputs

- 1 analog input or 2 analog inputs (for redundancy) to read braking/inching pedal position.
- CAN bus for 1 frequency input for pump speed sensor.

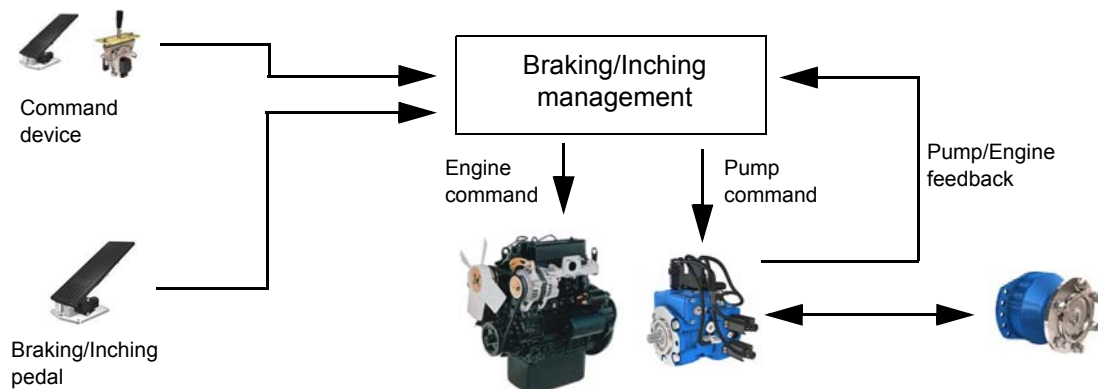

Model code

Technical specifications

Operating parameters

System parameters

Features

Controls

PMe package

PMe installation

Options

Appendixes

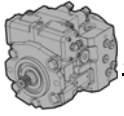

Speed control loop

Aim of the function

Provide constant machine speed whatever the engine speed.

Option 2 wheel speed sensors: Provide constant machine speed whatever the engine speed. The driving condition, the steering condition.

Description

SD-CT-30 monitors engine speed and adjusts pump displacement to keep constant machine speed (according to command device position).

Ergonomics

Driver must use display to activate the function. If not activated, engine speed can change machine speed.

Inputs/Outputs

- CAN bus or 1 frequency input for reading the speed of engine/pump
- CAN bus for display.
- Command device: joystick or pedal.
- (Option*) 2 wheel speed sensors
- * this option is available only with Q control

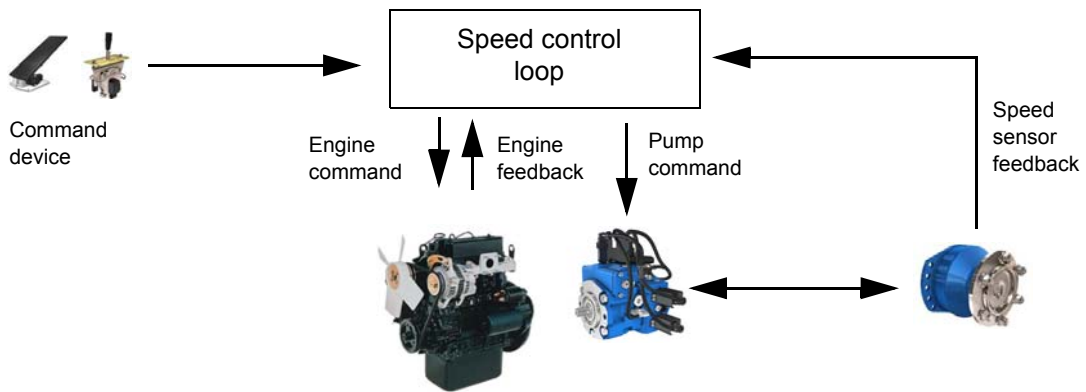

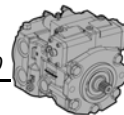

CAN slave management

Usage sum up

CAN communication used by CAN slave is matching J1939 communication rules and frame definition. Used PGN are defined within customer specific ID range.

To command the pump, following data are required:

- Pump direction (Neutral, direction A or direction B)
- Pump enable (Active or not)
- Pump command (in cc, with ramp management following parameter)

To improve safety of the command sent to the PMe pump throughout CAN bus, there is a counter that should be incremented each time a new can frame is transmitted. This counter is 8bits long and is free running. It will return to 0 after 255. A second message will be sent as redundancy purpose, it will contain one complemented data from main command frame. SD-CT-30 will check consistency between main and redundancy CAN frame. In case of recurrent discrepancy PMe pump will enter in safe mode and bring pump back to neutral.

Conditions of CAN communication that can stop the pump:

- If main or redundant messages are missing for 0.5s, pump will go back to neutral following a specific ramp (1.5s).
- If main and redundant messages are inconsistent 3 times (consecutively) pump will go back to neutral following a specific ramp (1.5s).
- If counter of main message isn't increasing, pump will go back to neutral following a specific ramp (1.5s).

To ensure that redundant message will not be received before main message, redundant message will be sent at least 10ms after main message.

After pump start-up an initial condition must be observed regarding the pump command to be able to stroke the pump. This initial condition must be:

- Pump command = 0cc
- Pump enable = FALSE
- Pump direction = Neutral

To inform master SD-CT-30 of transmission condition, pump will send CAN frames containing pressure, speed, temperature information. Those information will be transmitted in two ways:

- Physical values, computed using parameters value defining sensor characteristics.
- Electrical values that are direct RAW reading. Master SD-CT-30 will have to compute by its own physical values based on its own parameters. Master SD-CT-30 will also have to take care of signal range validity to detect sensor disconnection

Parametres dedicated to CAN slave communication

Name	Rate of PHPI messages
Description	Define the transmission period for PHPIx messages.
Min. value	0,01s
Max. value	0,20s
Name	Rate of PHPC messages and pump control tasks
Description	Define the typical period for PHPCx messages.
Min. value	0,01s
Max. value	0,10s
Name	Ramp of deceleration in case of fault
Description	Define the ramp used to bring the pump back to neutral when CAN communication is lost with master SD-CT-30. This parameter defines time in s taken to bring the pump from full displacement to neutral. (I.e. if the pump was stroked to half displacement when the fault occurred, it will take half the specified time to get back to neutral).
Min. value	0,5s
Max. value	6553,4s
Name	Wait for 1st valid command after powerUP
Description	Define the initial time allowed after PMe pump power up to start communication with master SD-CT-30. This is intended to let time to master SD-CT-30 to boot up and start CAN communication without triggering errors.
Min. value	0,1s
Max. value	30s

Model code

Technical specifications

Operating parameters

System parameters

Features

Controls

PMe package

PMe installation

Options

Appendixes

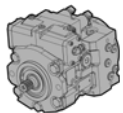

Name	Own J1939 address in Slave
Description	J1939 address of SD-CT-30
Min. value	0
Max. value	255

Name	J1939 address of commander
Description	J1939 address of master SD-CT-30
Min. value	0
Max. value	255



See page 84 for “Details of CAN messages for CAN slave” info.

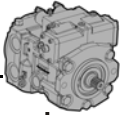

PME INSTALLATION

Glossary

Model code

Code describing the global system chosen by the customer, including components characteristics as well as software packages.

Software packages

The software package includes specific software functions that will provide features to the customer for the control of his machine.

SmartDrive™ CT-30

ECU embedded on the PMe pump.

CT design

CT design is a PC software that allows, after input of the model code, selecting the functions of the package and creates a customized embedded software accordingly. Generated file has a .ct format.



See page 74 for CT design manual.

Phases™ CT

Phases™ CT is a PC software that allows:

- sending the .ct file generated from CT Design to the SmartDrive™ CT-30 ECU
- Calibrating the command devices
- Changing parameters (eg. Wheel circumference)
- displaying inputs/outputs, errors, graphs



See page 74 for Phases™ CT description.

To adapt the command devices to the SmartDrive™ CT-30 ECU, they must be calibrated. The calibration has to be done for each machine.



Please make sure that the machine is in safety mode before sending the embedded software to the ECU (parking brake applied and command devices released).

.ct file

Generated file from CT design. It contains the SmartDrive™ CT-30 embedded software and is sent to the SmartDrive™ CT-30 with Phases™ CT.

.ctx file

This file contains all parameters of the machine.

Model code

Technical specifications

Operating parameters

System parameters

Features

Controls

PMe package

PMe installation

Options

Appendixes

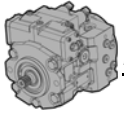

Installation

1 Do the wiring

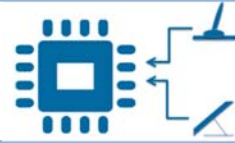

2 Generate a software .CT with CT design



3 Send the .CT file to the SmartDrive™ CT-30 with Phases™ CT



4 Calibrate the SmartDrive™ CT-30 using Phases™ CT

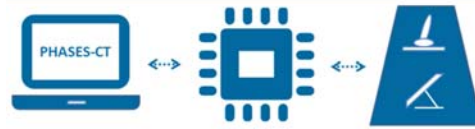

5 Check and adjust all parameter values using Phases™ CT



6 Check that there are no errors using Phases™ CT

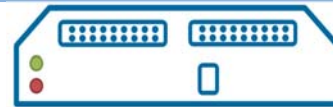

7 Apply the parking brake and turn on the ignition



8 Start the machine



See page 73 for machine safety recommendations.

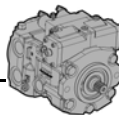

SD-CT-30 DESCRIPTION

SD-CT-30 pin-out

- The pump is delivered with its ECU (Electronic control unit) and its harness assembled
- The ECU is already programmed to manage the pump in according to the command interface
- The pump management can be optimized by using CT design software

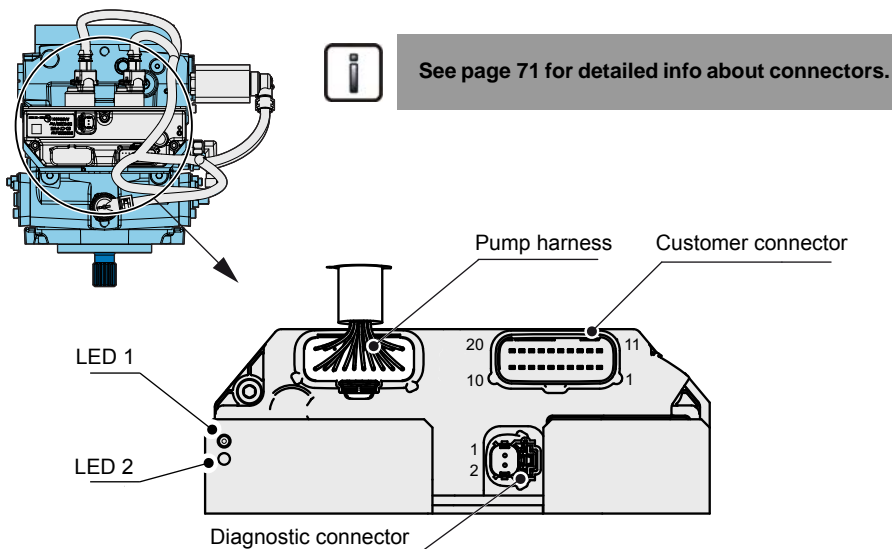

Pump harness

PIN	Function
1	Not used
2	Not used
3	Not used
4	Not used
5	S2 valve -
6	S1 valve -
7	S2 valve +
8	S1 valve +
9	Vbat sensor ground
10	Analog ground
11	Pump speed sensor
12	Temperature sensor
13	HPB pressure sensor
14	Not used
15	HPA pressure sensor
16	Not used
17	Not used
18	Not used
19	5V sensor supply
20	Vbat sensor supply

Customer connector

PIN	Name	Function	Wire gauge (mm ²)
1	DIGOUT_4	Rear shifting valve	0,75 to 1
2	DIGOUT_1	Fault lamp	0,75 to 1
3	DIG_2	Reverse_in	0,35 to 0,5
4	DIG_4	Neutral_in	0,35 to 0,5
5	NC	Not connected	
6	ANA_6	Inching/Braking pedal	0,35 to 0,5
7	CAN1L	Vehicle CAN 1 bus low	0,35 to 0,5
8	CAN1H	Vehicle CAN 1 bus high	0,35 to 0,5
9	AGND	Analog ground	0,35 to 0,5
10	VBAT -	Battery -	1,5 to 2
11	DIGOUT_3	Front shifting valve	0,75 to 1
12	DIGOUT_2	Brake lamp relay	0,75 to 1
13	DIG_1	Forward_in	0,35 to 0,5
14	DIG_3	P-brake_in	0,35 to 0,5
15	DIG_5	Operator presence	0,35 to 0,5
16	ANA_5	Travel pedal/Joystick/Inching	0,35 to 0,5
17	UN_1	Wheel speed signal 1/ Pump speed signal	0,35 to 0,5
18	UN_2	Wheel speed signal 2	0,35 to 0,5
19	5V SENSOR	5V sensor supply	0,35 to 0,5
20	VBAT+	Battery +	1,5 to 2

Diagnostic connector

PIN	Name	Function	Wire gauge (mm ²)
1	CAN2H	PH CAN bus high	0,35 to 0,5
2	CAN2L	PH CAN bus low	0,35 to 0,5

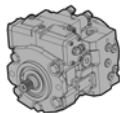

Wiring

CAN bus

The CAN bus must be wired using shielded or unshielded twisted pair. CAN bus must be wired according to SAE J1939-11 or SAE J1939-15.

If the SmartDrive™ CT-30 is in end of the line, add a termination resistor of 120Ω. For this Poclain Hydraulics offers 120Ω connector kit (KIT-PLUG-120-DTM-2S: A52539H).

CAN messages information:



All CAN messages information sent by SmartDrive™ CT-30 cannot be used for safety applications. For safety critical data by CAN, please contact your Poclain Hydraulics application engineer.

Supply

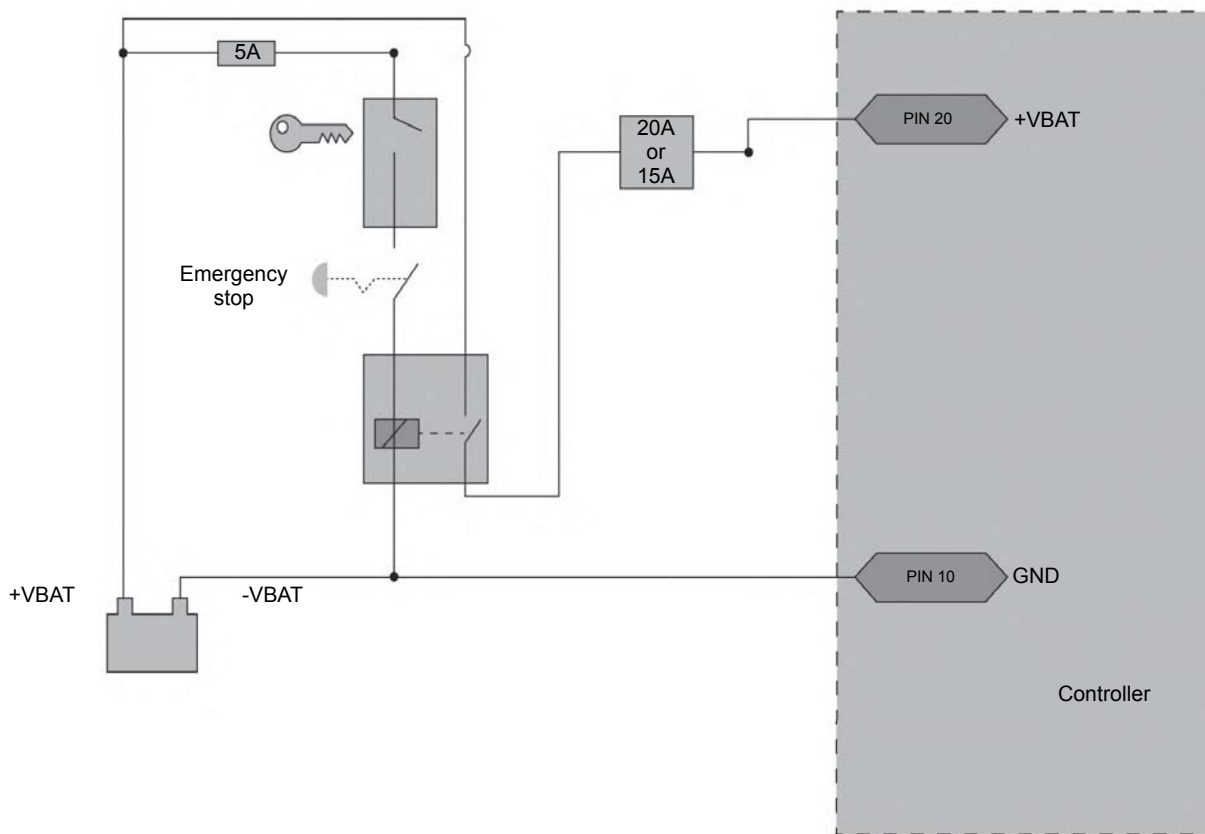

The correct wiring of the power supply pin (+VBAT) and pin connected to ground, is shown in previous figure. Power supply must be connected through an automotive fuse SAE J1284 20A or 15A.

A-GND pin is used as ground for analog sensors. It should not be connected to vehicle ground.

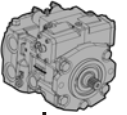

Auxiliary functions

Parking brake:

To prevent vehicle movement during engine start, it is recommended to wire parking brake switch in serial with starter.

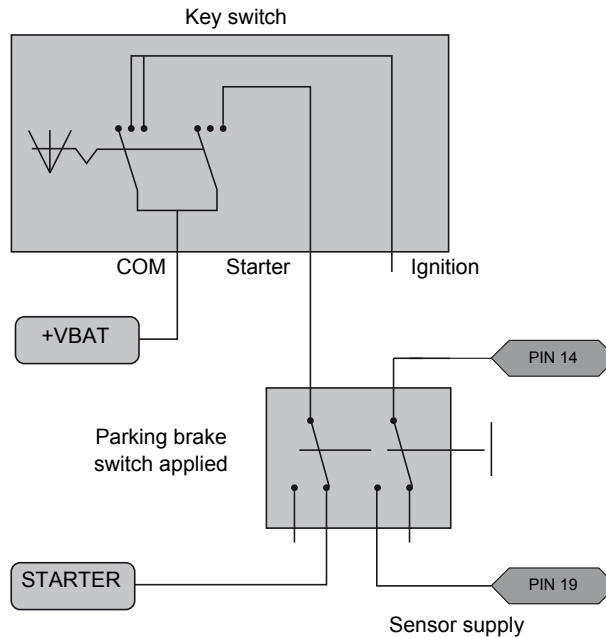

Parking brake lamp:

A lamp on the dashboard must give the real status of the parking brake.

The logic must be as follows:

- Lamp on, parking brake applied
- Lamp off, parking brake released

Operator presence switch:

Switch is wired between pin 15 and pin 19, it is open in when operator is not present.

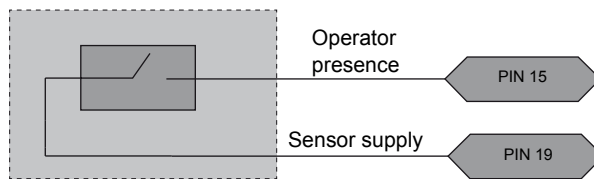

Fault lamp output:

Output is wired between pin 2 and pin 12 and power ground (Vbat-). Lamp has to be relayed.

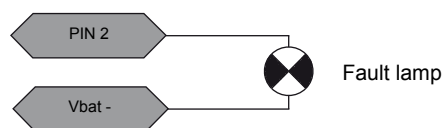

Model code

Technical specifications

Operating parameters

System parameters

Features

Controls

PMe package

PMe installation

Options

Appendixes

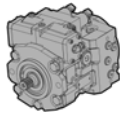

Brake lamp output:

Output is wired between pin 12 and power ground (Vbat-). Lamp has to be relayed.

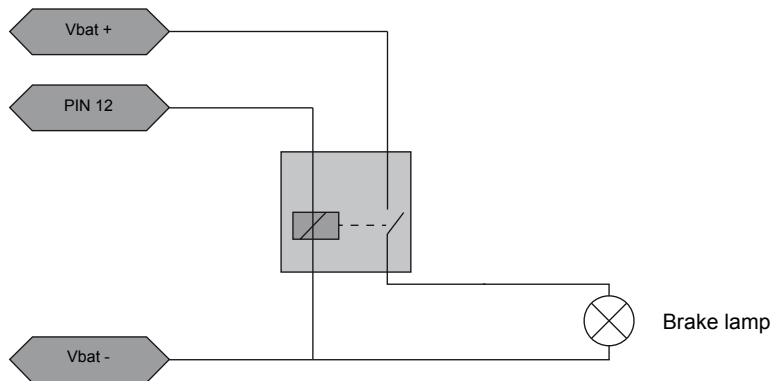

Vehicle CAN bus:

CAN high is pin 8, CAN low is pin 7.

The CAN bus must be wired using shielded or unshielded twisted pair.

If the SmartDrive™ CT-30 is in end of the line, add a termination resistor of 120Ω. For this Poclain Hydraulics offers 120Ω connector kit (KIT-PLUG-120-DTM-2S: A52539H).

External pump speed signal:

An external pump speed signal can be wired on pin 17.

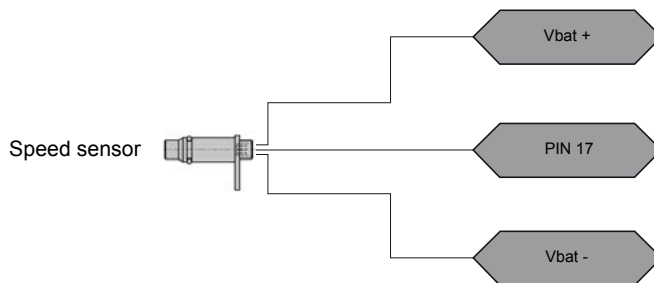

The pin 17 is used only if there is no speed sensor wired directly on the pump (same input is used).

Wheel speed signals:

For speed control loop or currents calibration, two speed sensors have to be installed: pin 17 & pin 18.



Wheel speed sensors are exclusive with pump sensors.

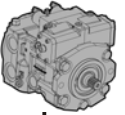

Pump command interface

Joystick

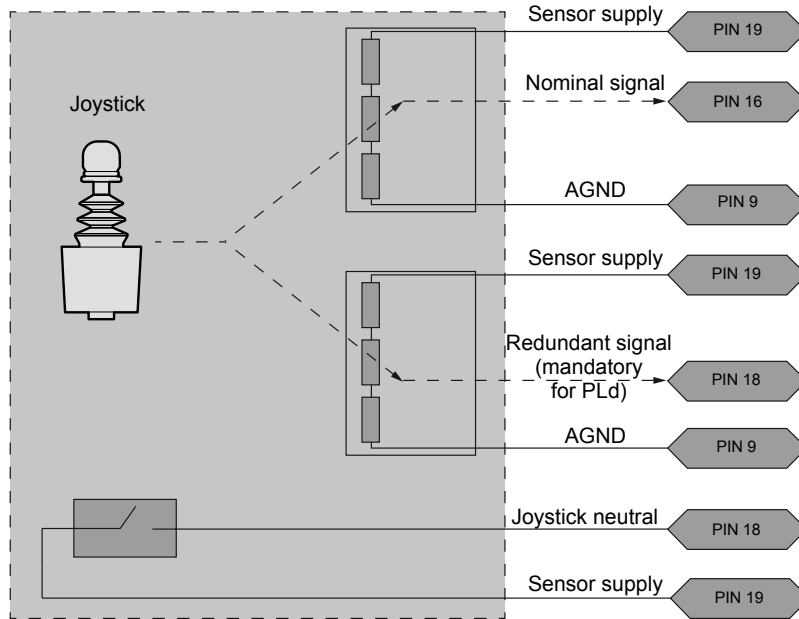

Safety requirements for compliance PLd, the joystick must:

- Be powered by the +5V OUT and A_GND
- Provide two independent signals:
 - These signals must be between 0.5V and 4.5V to detect open circuits and short circuits.
 - The source signal will vary from 2.5V to 4.5V for forward and 2.5V to 0.5V for reverse.
- Provide a neutral signal (contact closed in forward or reverse).
 - Does not operate when supply is in reverse polarity (signal has to be out of range 0,5V-4,5V).

It is imperative to perform a calibration in operations of installation / commissioning and maintenance / repair on safety-critical inputs (pedal, joystick, ...), to take account of the complete measurement chain (physical implementation, sensor harness, controller ...). The customer has to use a joystick for EMC directive of machine application field (Off-road/On-road).



If you are using Poclain Hydraulics redundant Joystick, it is important that the pinning for the connectors are as followed: signal 2 is the nominal signal, signal 1 is the redundant signal.

- Model code
- Technical specifications
- Operating parameters
- System parameters
- Features
- Controls
- PMe package
- PMe installation
- Options
- Appendixes

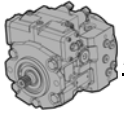

Travel pedal

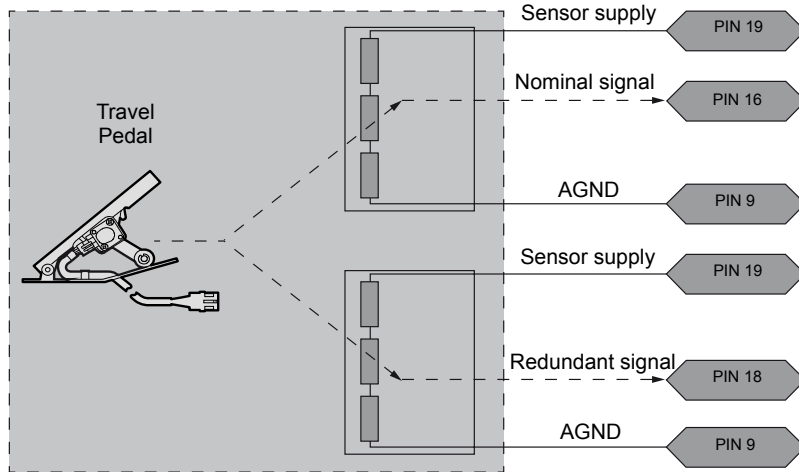

Safety requirements for compliance PLd, the sensor must:

- Be powered by the +5V OUT and A_GND
- Provide two independent signals:
 - These signals must be between 0.5V and 4.5V to detect open circuits and short circuits.
 - The signal source should be 0.5V when the pedal is released and 4.5V when the pedal is fully depressed.
 - Not operate (signal has to be out of range 0,5V-4,5V) when supply is in reverse polarity.

It is imperative to perform a calibration in operations of installation / commissioning and maintenance / repair on safety-critical inputs (pedal, joystick, ...), to take account of the complete measurement chain (physical implementation, sensor, harness, controller ...). The customer has to use a travel pedal for EMC directive of machine application field (Off-road/On-road).

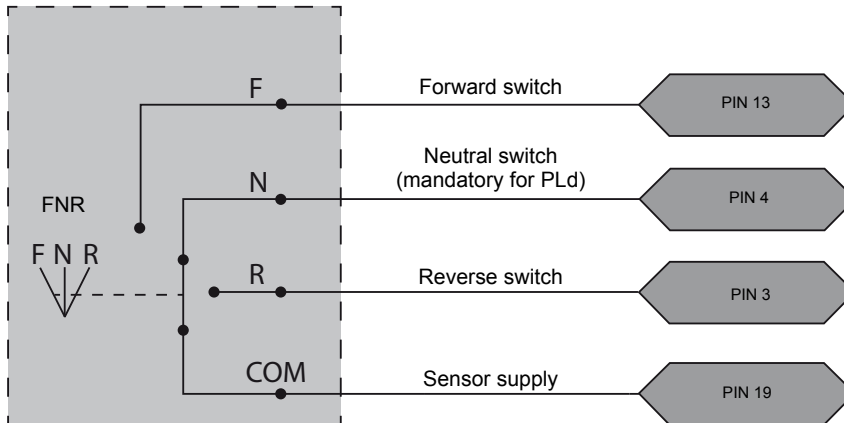

Safety requirements for compliance PLd, the sensor must:

- Provide three logic signals remain independent
- Not be connected to loads (valve) in parallel
- Have gold contacts

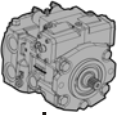

DA-like automotive

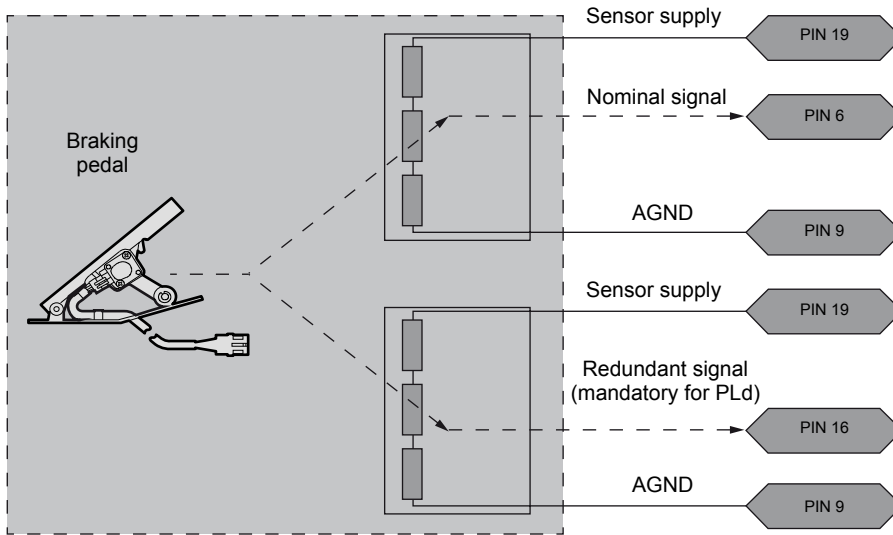

Safety requirements for compliance PLd, the braking pedal must:

- Be powered by the +5V OUT and A_GND
- Provide two independent signals:
 - These signals must be between 0.5V and 4.5V to detect open circuits and short circuits.
 - The signal source should be 0.5V when the pedal is released and 4.5V when the pedal is fully depressed.
 - Not operate (signal has to be out of range 0,5V-4,5V) when supply is in reverse polarity.

It is imperative to perform a calibration in operations of installation / commissioning and maintenance / repair on safety-critical inputs (pedal, joystick, ...), to take account of the complete measurement chain (physical implementation, sensor, harness, controller ...). The customer has to use a brake pedal for EMC directive of machine application field (Off-road/On-road).

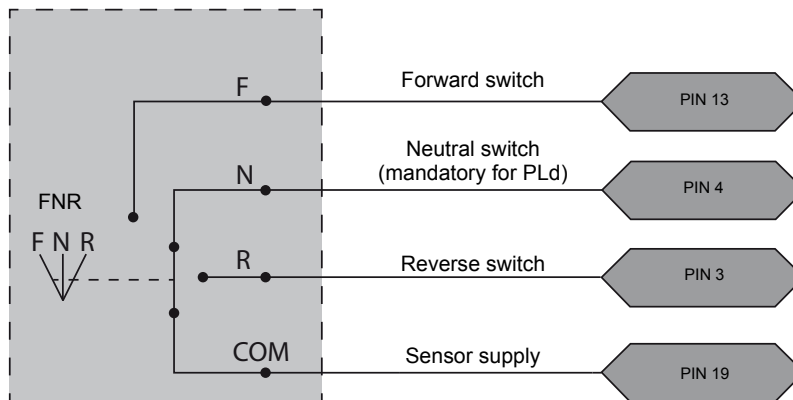

Safety requirements for compliance PLd, the sensor must:

- Provide three logic signals remain independent
- Not be connected to loads (valve) in parallel
- Have gold contacts

Model code

Technical specifications

Operating parameters

System parameters

Features

Controls

PMe package

PMe installation

Options

Appendix

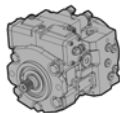

Braking-Inching pedal

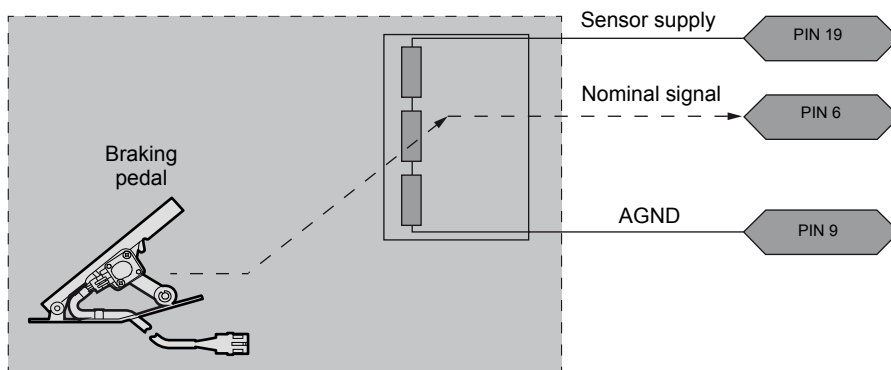

Safety requirements for compliance PLd, the braking pedal must:

- Be powered by the +5V OUT and A_GND
 - This signal must be between 0.5V and 4.5V to detect open circuits and short circuits.
 - The signal should be 0.5V when the pedal is released and 4.5V when the pedal is fully depressed.
 - Not operate (signal has to be out of range 0,5V-4,5V) when supply is in reverse polarity.

It is imperative to perform a calibration in operations of installation / commissioning and maintenance / repair on safety-critical inputs (pedal, joystick, ...), to take account of the complete measurement chain (physical implementation, sensor, harness, controller ...).

The customer has to use a brake pedal for EMC directive of machine application field (Off-road/On-road).

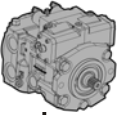



Auxiliaries

Customer connector

Characteristics



Commercial name	KIT-CONNECT-PWE-CUSTOMER
Poclain Hydraulics part number	B03982C
Function	SD-CT-30 Counter-part connectors
Compatibility	Electronic transmission management with SD-CT-30

Component		Molex reference	Quantity	Wire gauge
Connector		33472-2001	x1	
Pin		33012-3001	x2	1,5 to 2 mm ² [0.0023 to 0.0031 in ²]
Pin		33012-3002	x4	0,75 to 1 mm ² [0.0011 to 0.0015 in ²]
Pin		33012-3003	x14	0,35 to 0,5 mm ² [0.0005 to 0.0007 in ²]
Plug		34345-0001	x20	
Insulation diameter				1,5 to 2,5 mm [0.05 to 0.098 in]
Operating temperature				-40°C to 125°C [-40°F to 257°F]

Female diagnostic connector (SD-CT-30 counter part)

Characteristics

Commercial name	KIT-CONNECT-PWE-DIAG
Poclain Hydraulics part number	B03983D
Function	SD-CT-30 Counter-part connectors
Compatibility	Electronic transmission management with SD-CT-30

Component		Molex reference	Quantity	
Connector		33471-0201	x1	
Pin		33012-3003	x2	
Wire gauge				0,35 to 0,5 mm ² [0.0005 to 0.0007 in ²]
Insulation diameter				1,2 to 2,69 mm [0.047 to 0.105 in]
Operating temperature				-40°C to 125°C [-40°F to 257°F]

Model code

Technical specifications

Operating parameters

System parameters

Features

Controls

PMe package

PMe installation

Options

Appendixes

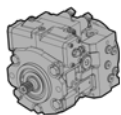

Male diagnostic connector (for cabin usage interface)

Characteristics

Commercial name	KIT-CONNECT-MX2-M
Poclain Hydraulics part number	B26740P
Function	Extension of SD-CT-30 diagnostic male connector for cabin usage
Compatibility	Electronic transmission management with SD-CT-30

Component	Molex reference	Quantity
-----------	-----------------	----------

Connector		33481-0201	x1
-----------	---	------------	----

Pin		33000-1003	x2
-----	---	------------	----

Wire gauge	0,35 to 0,5 mm ² [0.0005 to 0.0007 in ²]
Insulation diameter	1,2 to 2,69 mm [0.047 to 0.105 in]
Operating temperature	-40°C to 125°C [-40°F to 257°F]

Tools

Description	Molex reference	Wire gauge
-------------	-----------------	------------

Crimping tool		63811-5900	1,5 mm ² to 2 mm ²
---------------	---	------------	--

Crimping tool		63811-6000	0,35 mm ² to 1 mm ²
---------------	---	------------	---

Pin extractor		63813-1500	
---------------	---	------------	--

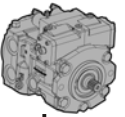

Machine safety recommendations

Poclain Hydraulics has identified requirements for the controller, sensors and actuators to meet and satisfy the requirements of a performance level d according to ISO 13849-1 (PLd) at the vehicle system. To quantify for a performance level d (PLd) it is imperative to adhere to at least the following:



A risk analysis must be conducted by the manufacturer to ensure the non-hazardous nature of the machine in case of failure on one of these components.



The safe state is opening of HSD and LSD (Pump coils). The customer must realize a safety analysis of the machine to check that there is no safety aspect due to the opening of the HSD and LSD (Pump back to neutral).

Installation and commissioning:



Upon system design and configuration, it could be needed to perform calibrations of safety critical inputs, to take into account the complete measurement chain (physical implementation, sensor, harness, controller...).

Maintenance and repair:



Any maintenance or repair of the controller shall be done according to the warranty terms. Otherwise, the integrity of the controller and the effectiveness of safety principles can not be guaranteed.

Precaution before maintenance and repair:



Before any maintenance or repair or decommissioning the controller must be disconnected from the power source, in particular before disconnecting interfaces connectors. To perform this operation, it is recommended to disconnect the battery fully after complete stop of the vehicle and its engine.

Operation after maintenance and repair:



After maintenance or repair of the machine, it is necessary to perform a calibration of the safety inputs.

Caution during electric welding:



The connectors on the controller and associated sensors must be disconnected during the electric welding process.

Pump:



The safety state of a hydrostatic transmission is stopped vehicle by a rapid and mastered return to neutral of the pump.

To do so, it is necessary to add:

- restrictors to be correctly sized depending on the application, the machine ... When using multi-displacements motors, provide a bypass valve for these restrictors.
- A cut-off valve, allowing to bypass the supply of the pump.

Starting up the engine:



Place the machine on the wheel blocks. Set up a safety area. Observe all personnel safety instructions.

Model code

Technical specifications

Operating parameters

System parameters

Features

Controls

PMe package

PMe installation

Options

Appendixes

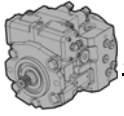

CT Design and Phases™ CT

CT Design software enables you to configure electronic functions of your PME pump. It provides a ".ct file" that you can use with Phases™ CT software to configure SmartDrive™ CT-30. CT Design application can be downloaded at: <http://phases.poclain-hydraulics.com/downloadcenter>

Phases™ CT is used to:

- Download the "CT file" on SmartDrive™ CT-30
- Adjust and control the operating parameters of the SmartDrive™ CT-30
- Calibrate and check the functionality of the sensors connected to the SmartDrive™ CT-30
- Diagnose the possible malfunctions of the hydrostatic transmission by displaying the logical error log memorized by the SmartDrive™ CT-30

To get Phases™ CT documentation, use the following link: http://www.poclain-hydraulics.com/_upload/ressources/media/pdf/A48680N.pdf

- Install Phases™ CT software (see installation guide No. A48680N)
- Connect the SmartDrive™ CT-30 to the PC by connecting the USB port with controller's communication connector (CAN bus link) via cable COM-CABLE-PWE-MOLEX (P/N B08453M), SUBD9 connector with integrated 120 termination resistor and adapter CABLE-USB-CONVERTER (P/N A48780W).



These cables are supplied with Phases™ CT kit (P/N B29588K).

We propose three solutions for communicating with the SmartDrive™ CT-30 controller

Diagnostic connector (connector 3) is free on controller, not used by display

- Remove the connector cap and connect the diagnostic cable.

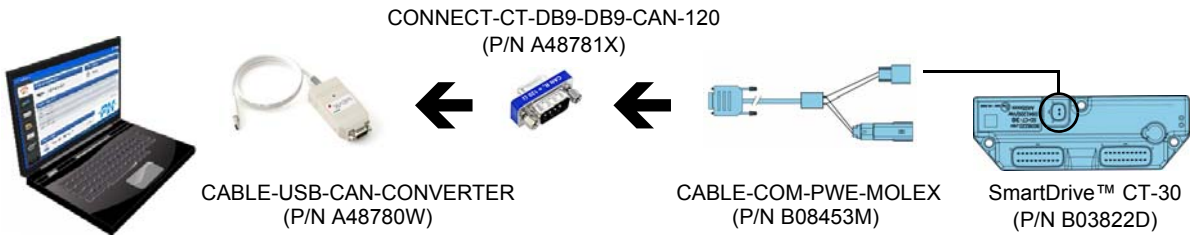

Display is already connected on diagnostic connector (connector 3)

- You must insert diagnostic cable between controller and display.

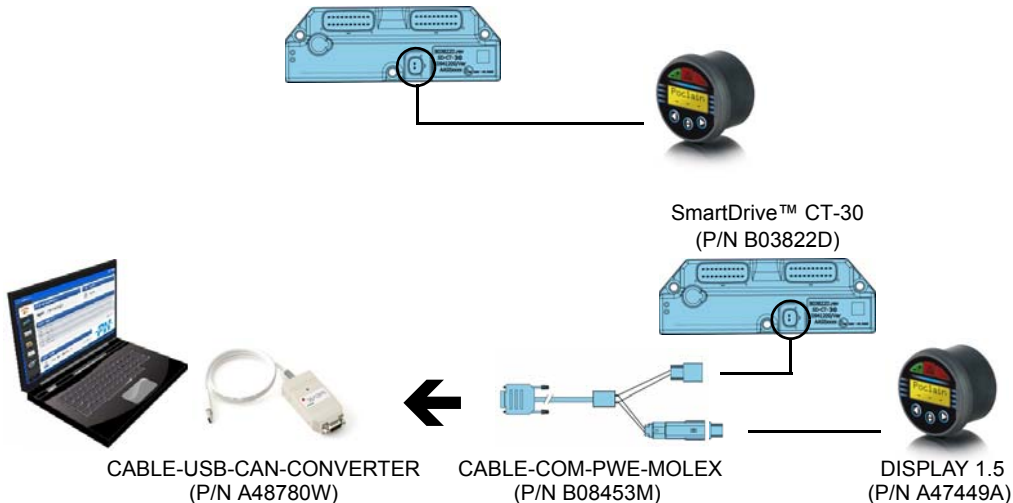

Do not put the CAN termination (P/N A48781X) because it is already present near to display.

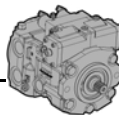

Checking the installation before starting up



The elements to be checked depend on the application of each vehicle. Please remember that each manufacturer is ultimately responsible for checking their machinery at the end of the line.

Using diagnostic connector in cabin (remote connector)

Male connector in cabin

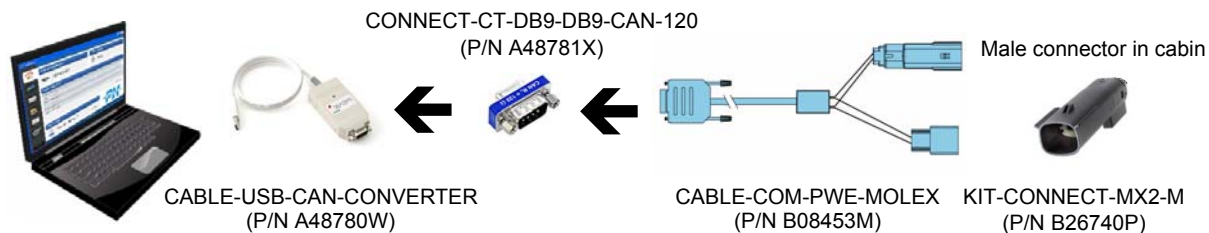

Male J1939 connector in cabin

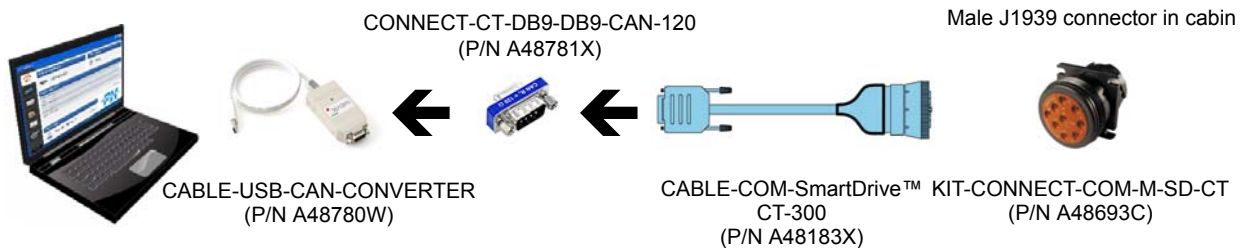

If a display is already connected on diagnostic connector, do not put CAN termination.



For further information, see SmartDrive™ CT-30 catalogue no. B51230J.

Model code

Technical specifications

Operating parameters

System parameters

Features

Controls

PMe package

PMe installation

Options

Appendixes

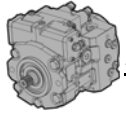
**SmartDrive™ CT-30 characteristics**

Operating voltage	8 V to 32 V
Operating temperature	- 40°C to 100°C [-40 °F to 212°F]
Material	PA66 30% GF; Silicon (potting)
Mass	0,225 kg ±10% [0,496 lb] ±10%
Ingress protection (with mating connectors mounted)	IP6K9K (ISO20653)
12V system max. current	17 A
24V system max. current	8,5 A
Performance level	Capacity to reach PL d level according to ISO13849:2006 standard
Mean Time To Failure (MTTF)	162 years (duty cycle is 229 days of 8 hours)
Mean Time To Dangerous Failure (MTTFd)	324 years
Diagnostic Coverage (DC)	95.4 %
Category	2
Electrical protection	Over-voltage, reverse polarity (with fuse), ground and battery short circuit
ECU programming	Programming with a PC using the PHASES™ CT software application
ECU set-up	Set-up with the software PHASES™ CT
Digital inputs	5
Analog inputs (AN)	7
Universal inputs	2
HSD PWM outputs	4
HSD DIG 2,6A outputs	2
HSD DIG 0,5A outputs	2
Sensor supply 5V	1

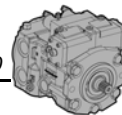

SmartDrive™ CT-30 environmental performances

Type	Standard	Parameters
EC marking	2004/108/EC	
Electro-Magnetic Compatibility	EN/ISO14982:2009	Agricultural and forestry machines
Electro-Magnetic Compatibility	EN13309:2010	Construction machines
Electro-Magnetic Compatibility	EN12895:2000	Forklifts
E marking	2004/104/EC	Automotive EMC directive

SmartDrive™ CT-30 input characteristics

Digital inputs

- These inputs are active in high side
- They are protected against short circuits to ground, battery and over voltage up to +48 V

Input range	0 to 32 V
Max. voltage for low level	1,75 V
Min. voltage for high level	3,25 V
Switch current	10 mA under 28 V

Analog inputs

- These inputs are populated to perform 0-5V measurement.
- These inputs are protected against short-circuit to ground and battery.

Input range	0 to 5V
Input resistance	>170 kΩ
Resolution	12 bits
Full scale accuracy	1%

Universal inputs

Input range	1 Hz to 8500 Hz
Max. voltage for low level	1,65 V
Min. voltage for high level	3,85 V
Switch current in PNP mode	15 mA (input at 28 V)
Switch current in NPN mode	10 mA (input at 0 V, supply voltage at 28 V)
Accuracy	< 1%

Model
codeTechnical
specificationsOperating
parametersSystem
parameters

Features

Controls

PMe
packagePMe
installation

Options

Appendixes

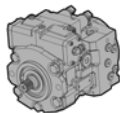

SmartDrive™ CT-30 output characteristics

PWM outputs 2A at 12V (1A at 24V)

These outputs can be configured in PWM mode and current control.

DC voltage (ON state)	Voltage drop of 1V maximum
DC current control	2 A max. at 12V and 1A max. at 24V
PWM frequency	100 to 500 Hz
PWM duty cycle	0 or 5% to 100%, resolution of 0,6%

Digital outputs 2,6A (STOR 3/4) at 12V (1,3A at 24V)

DC voltage (On state)	Voltage drop of 1V maximum
DC current	2,6 A max.(inductive load) at 12V and 1,3A at 24V

Digital outputs 0,5A (STOR 1/2)

DC voltage (On state)	Voltage drop of 1V maximum
DC current	0,5 A max. (resistive load)

Sensor supply 5V output

DC voltage (On state)	5V ±2%
DC current	200 mA max.

Communication

CT-30 has 2 CAN standards 2.0A or extended 2.0B buses, whose speed can reach 500 kb/s max.

- CAN 1 is used to communicate with customer machine.
- CAN 2 is used for downloading, diagnostic and communication with other Poclain Hydraulics components.

LED

SmartDrive™ CT-30 has 2 LEDs for diagnostic:

LED 1	Permanent green: Power supply Led OFF: ECU not powered or problem
LED 2	5Hz red blinking: Safety error 1Hz red blinking: System error 1 green flash at 2Hz: pump stroked 1 green flash at 1Hz: wait for initial condition (safety check) Fixed green: pump in neutral 1 orange flash 1Hz: Parameter load failure 2 orange flash 1Hz: Wrong MAF LED OFF: ECU problem



If some of these conditions are active simultaneously, the LED will light according to the first condition and then will be off for 0,5s and light again according to second condition.



LED 2 is bi-color (red or green) and it's controlled by applicative software for diagnostic.

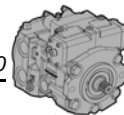

OPTIONS

Roller bearing (for PM/PMe50)



The PM/PMe50 can be provided with high capacity roller bearing to extend lifetime of the application. According to characteristics of shaft load, the duty cycle and lifetime expectancy a roller bearing might be needed.



Consult your Poclain Hydraulics application engineer.

Customized identification plate (for PM/PMe50)



The PM/PMe50 can be provided with customized identification plate (customer part number engraved on the plate).



This option is available only for minimum volume of 50 pieces.



Consult your Poclain Hydraulics application engineer for other possibilities.

Mechanical inching (only for PM50)



The PM50 with Hydraulic automotive control D (page 37) can be provided with an Inching lever to reduce the pilot pressure independently of the pump rotation speed.

Hydraulic inching (only for PM50)



The PM50 with Hydraulic automotive control D (page 37) can be provided with a pressure reducer valve (connected with port K). Its function is to reduce the displacement of pump. The pedals type VB3-002 (only inching function) or VB3-012 (inching and service brake function) can be provided upon request.

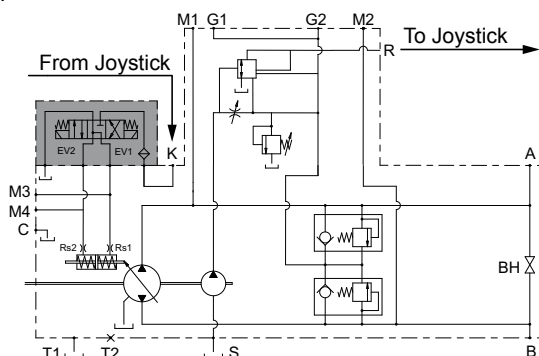

- Model code
- Technical specifications
- Operating parameters
- System parameters
- Features
- Controls
- PMe package
- PMe installation
- Options
- Appendix

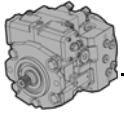

Filter on pressure line (for PM/PMe50)

The PM/PMe50 can be provided with a F0/F2 filter. It's placement on pressure line ensures that only filtered oil enters the pump closed loop. Maximum pressure difference between filter cartridge input and output is 2 bar [29 PSI]. After reaching 2 bar [29 PSI], the cartridge has to be changed.

Tightening torque: 35 Nm [309 in.lbf]. Max. working pressure: 30 bar [435 PSI]. Filter fitness is of 10 micron.

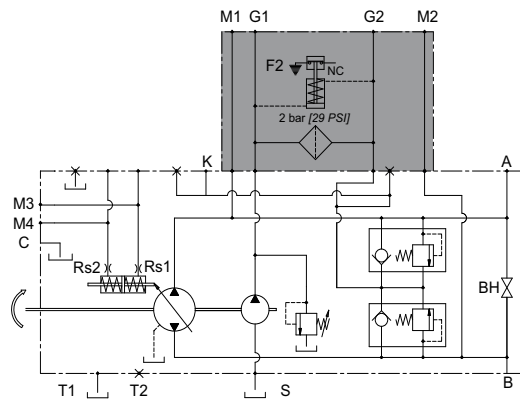
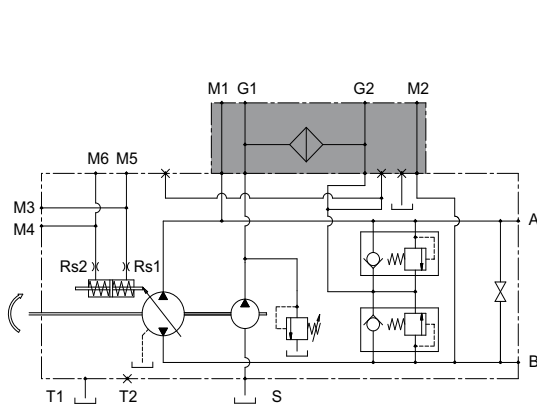
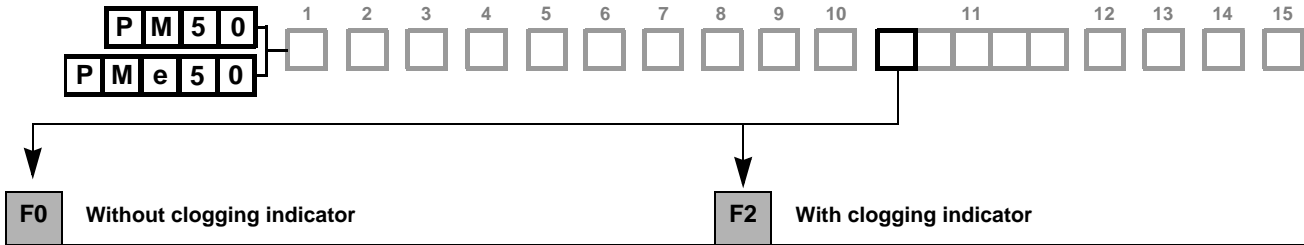

Clogging indicator specification

Differential working adjustment	3 ± 0,2 bar [44 ± 3 PSI]
Working temperature	-30°C ~ 110 °C [-22°F ~ 230°F]
Max. vibration level	50 g
Connector type	AMP super seal, 2 way
Current range	0,1-0,2 A max.

Port	Function	UNF ISO 11926-1	GAS ISO 1179-1
G1/G2	Auxiliary/Charge pressure	9/16-18 UNF-2B	13G-G1/4
M1/M2	A/B pressure	9/16-18 UNF-2B	13G-G1/8

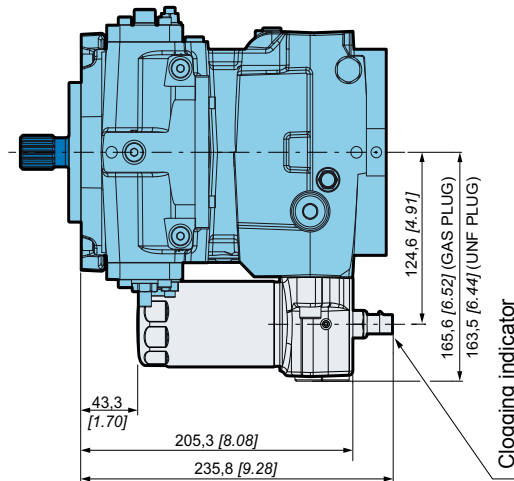
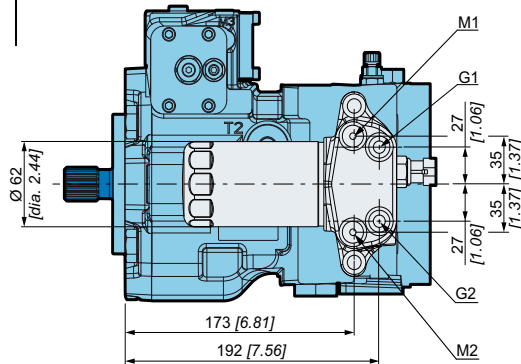

Normally closed contact. Thread of the clogging indicator is internally connected to ground.

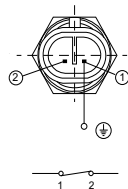

This option is not compatible with option SS (Speed sensor T4) and PS (Pressure sensors on A&B lines).



In case of tandem pump use, each pump must be equipped with it's own filter and charge pump.

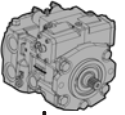

External connections for filter (only for PM50)

1 2 3 4 5 6 7 8 9 10 11 **F3**

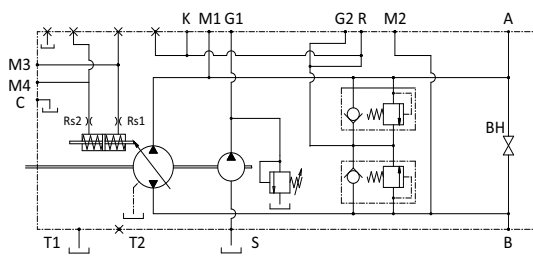
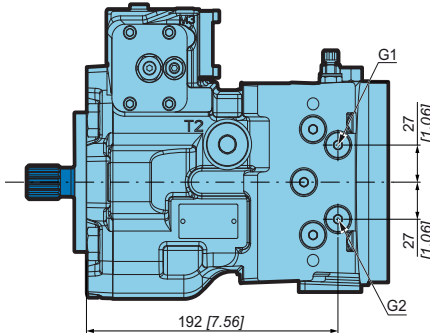

G1 = to filter on line
G2 = Return from filter on line



This option is not compatible with option PS (Pressure sensors on A&B lines).

SAE flange ports (for PM/PMe50)

1 2 3 4 5 6 7 8 9 10 11 **FS** 12 13 14 15

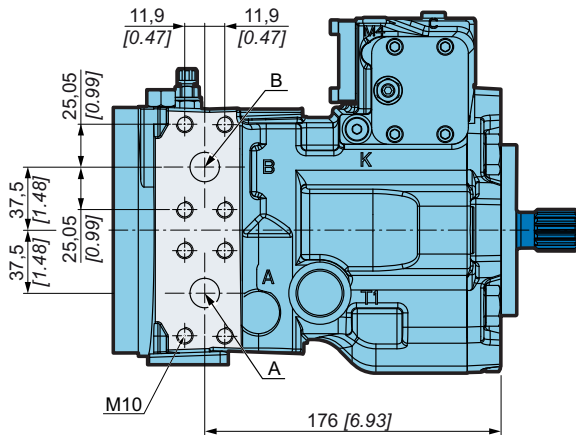

Port	Function	SAE flange
A-B	Services	PN400-DN19 4xM10
C	Case pressure	13G-G1/4
G1/G2	Auxiliary/Charge pressure	13G-G1/4
M1/M2	A/B pressure	10G-G1/8
M3/M4	Servo control	13G-G1/4
K	External servo pilot	10G-G1/4
R	Servo pilot pressure	13G-G1/4
S	Suction	34G-G1
T1/T2	Drain	27G-G3/4

UNF threads ports (for PM/PMe50)

1 2 3 4 5 6 7 8 9 10 11 **FU** 12 13 14 15

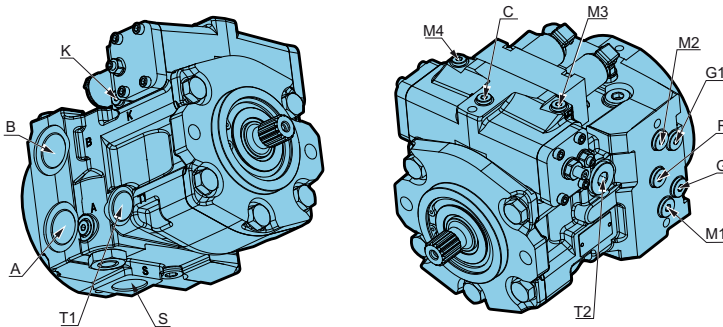

Port	Function	UNF ISO 11926-1
A/B	Services	1"5/16-12 UNF-2B
C	Case pressure	9/16-18 UNF-2B
G1/G2	Auxiliary/Charge pressure	9/16-18 UNF-2B
M1/M2	A/B pressure	9/16-18 UNF-2B
M3/M4	Servo control	9/16-18 UNF-2B
K	External servo pilot	7/16-20 UNF-2B
R	Servo pilot pressure	9/16-18 UNF-2B
S	Suction	1"5/16-12 UNF-2B
T1/T2	Drain	1"1/16-12 UNF-2B



Special fittings needed to ensure compatibility with option SS (Speed sensor T4) and PS (Pressure sensors on A&B lines). Consult your Poclain Hydraulics application engineer.

Model code

Technical specifications

Operating parameters

System parameters

Features

Controls

PMe package

PMe installation

Options

Appendix

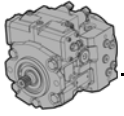

Neutral position switch (only for PM50)



The PM50 with Mechanical servo control A (page 31) can be provided with a micro switch to avoid engine start in case the control lever is not centered (zero position).

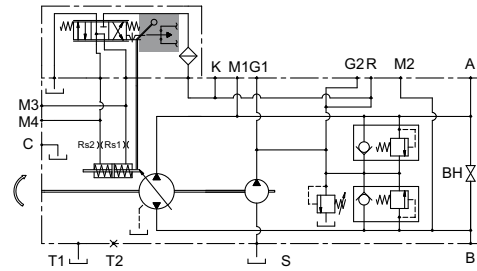
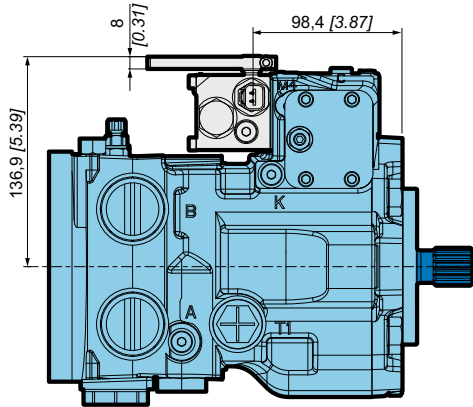

Electrical characteristics

Type of connector	Deutsch DT04-2P
Output	NC and NO
Cable connections	PG 13,2
Max. current	10 A
Electric load type	Resistive
Operating temperature	from -25°C to 80°C [-13°F to 176°F]
Type of protection	IP 67

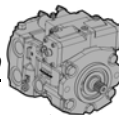

Safety valve (only for PM50)



The PM50 with Mechanical servo control A (page 31) can be provided with a safety valve VPU. Without current, the VPU disconnects the servo control from the charge pressure and engages negative brake.

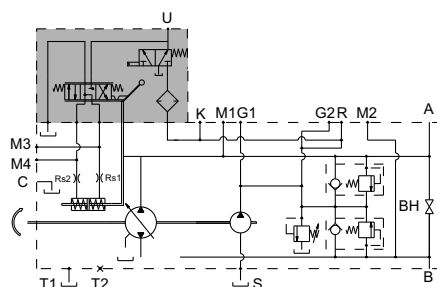
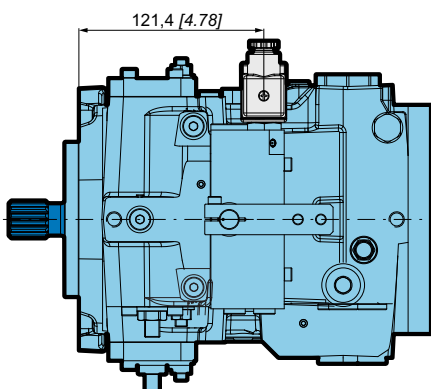
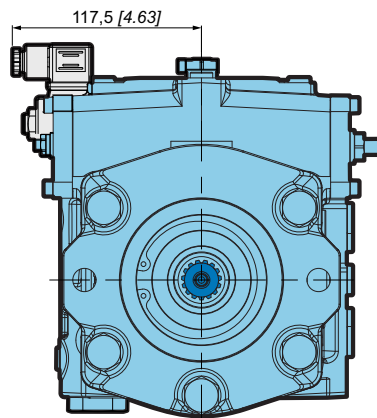
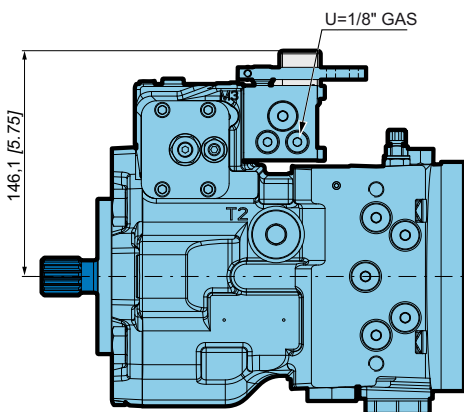

Coil specification

Type of connector	DIN 43650
Nominal voltage	12V DC
Power	18W
Type of protection	IP 65
Ambient temperature range	from -30°C to 60°C [-22°F to 140°F]
Magnet wire insulation	Class H -> 200°C [392°F]
Heat insulation	Class H -> 180°C [356°F]
Mass	0,19 kg [0.42 lb]
Lead wires	600V rating with strain relief

Connector specification

AC rated voltage	250V max.
DC rated voltage	300V max.
Pin contact rated flow	10A
Pin contact max. flow	16A
Max. cable section	1,5 mm ² [0.002 in ²]
Ø Cable gland PG09-M16x1,5	6 to 8 mm [0.24 to 0.31 in]
Type of protection	IP65 EN60529
Insulation class	VDE 0110-1/89
Operating temperature	from -40°C to 90°C [-40°F to 194°F]

Model code

Technical specifications

Operating parameters

System parameters

Features

Controls

PMe package

PMe installation

Options

Appendix

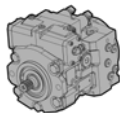

Safety valve (only for PM50)



The PM50 pump with Hydraulic servo control S (page 33) can be provided with a safety valve VPU. Without current, the VPU disconnects the servo control from the charge pressure and engages negative brake.

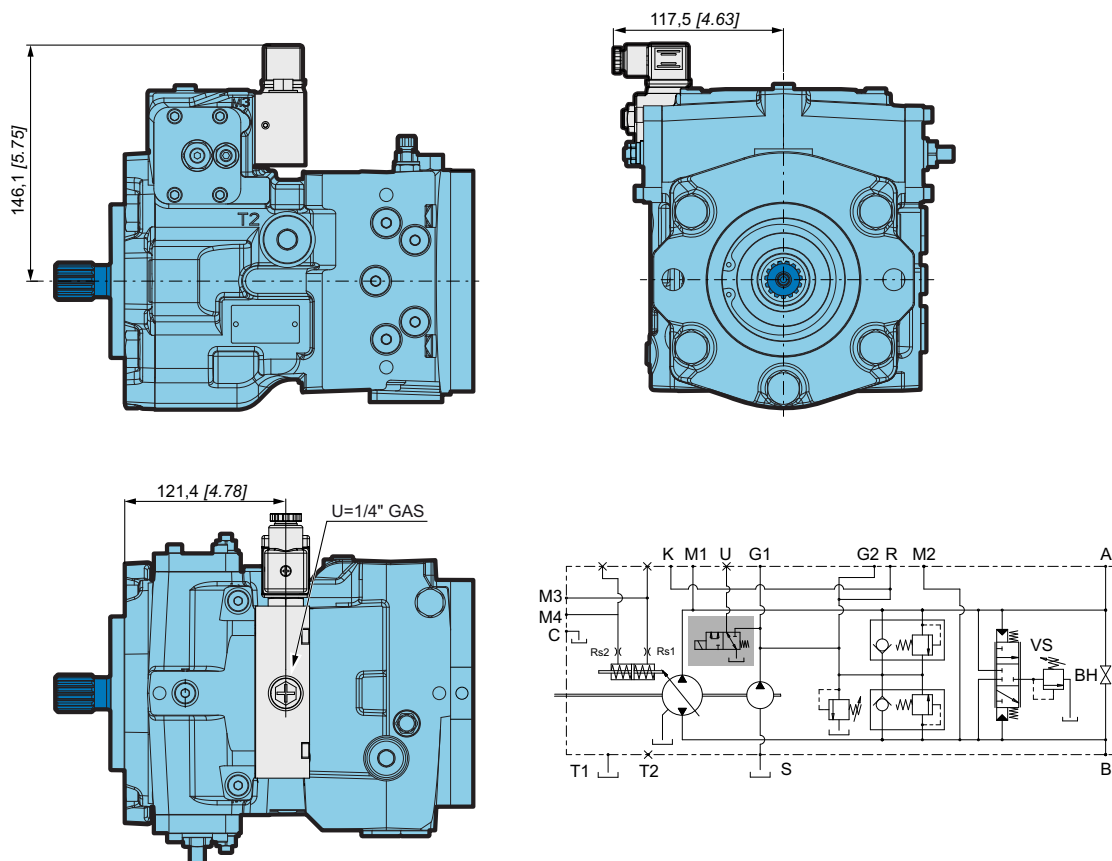

Coil specification	
Type of connector	DIN 43650
Nominal voltage	12V DC
Power	18W
Type of protection	IP 65
Ambient temperature range	from -30°C to 60°C [-22°F to 140°F]
Magnet wire insulation	Class H -> 200°C [392°F]
Heat insulation	Class H -> 180°C [356°F]
Mass	0,19 kg [0.42 lb]
Lead wires	600V rating with strain relief

Connector specification	
AC rated voltage	250V max.
DC rated voltage	300V max.
Pin contact rated flow	10A
Pin contact max. flow	16A
Max. cable section	1,5 mm ² [0.002 in ²]
Ø Cable gland	6 to 8 mm [0.24 to 0.31 in]
Type of protection	IP65 EN60529
Insulation class	VDE 0110-1/89
Operating temperature	from -40°C to 90°C [-40°F to 194°F]

Finishing coat (for PM/PM50)



PM/PM50 can be provided with finishing coat when requested. Standard paint is RAL 9005 (black color).



Consult your Poclain Hydraulics application engineer for other colors of topcoat.

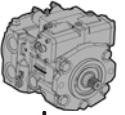

Flushing valve (for PM/PMe50)



The PM/PMe50 can be provided with a flushing valve to discharge the oil inside the pump casing through a relief valve of the flushing valve. The exchange valve is useful in case the temperature of the oil in the closed circuit is too high.

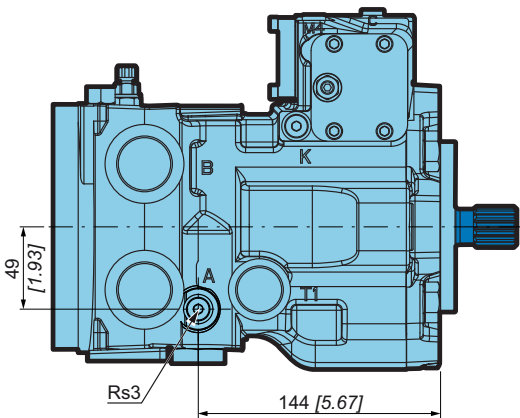
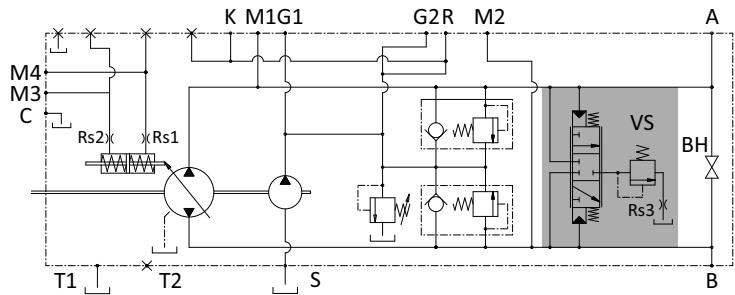
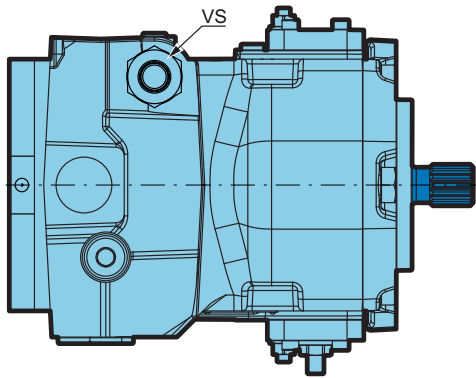

Flushing flow L/min [gal/min]

	Delta pressure bar [PSI]	Orifice diameter Rs3 mm [in]		
		1,4 [0.055]	1,8 [0.071]	2,2 [0.087]
20 [290]	2,8 [0.75]	4,5 [1.19]	5,5 [1.46]	
25 [363]	3,6 [0.96]	5,9 [1.55]	7,2 [1.90]	
30 [435]	4,3 [1.13]	7,0 [1.85]	8,5 [2.26]	



Refer to Poclain Hydraulics service manual for info about restrictor Rs3 exchange.



Contact you Poclain Hydraulics application engineer for restrictor Rs3 selection.

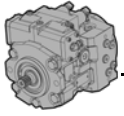

Speed sensor (for PM/PMe50)

P	M	5	0	1	2	3	4	5	6	7	8	9	10	SS	11	12	13	14	15
P	M	e	5	0															

The PM/PMe50 can be provided with a speed sensor.

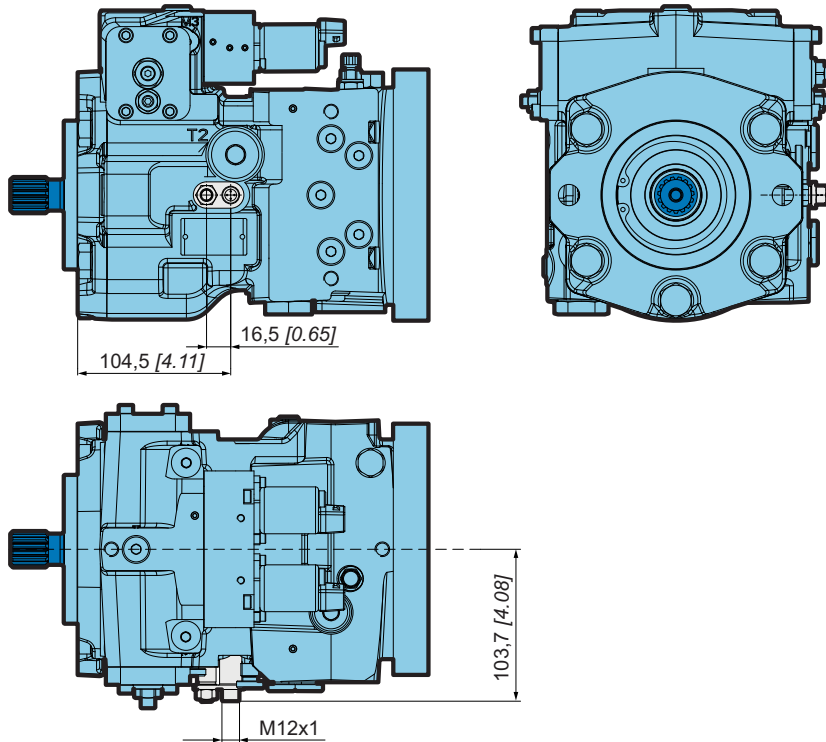

See the Mobile Electronics No. A01889D technical catalogue for the sensor specifications and its connection.



Speed sensor sends a signal of 9 pulses / revolution.



This option is not compatible with “speed regulation loop with 2 sensors”.



This option is not compatible with options F0 and F2 (page 80).

Fluorinated elastomer seals (for PM/PMe50)

P	M	5	0	1	2	3	4	5	6	7	8	9	10	EV	11	12	13	14	15
P	M	e	5	0															

The PM/PMe50 can be provided with fluorinated elastomer seals. Standard NBR sealing are designed to resist to temperature up to 90°C [194°F] and to HV type oils. If your application is outside these limits, fluorinated elastomer seals might be needed.



For application of this option please contact your Poclain Hydraulics application engineer.

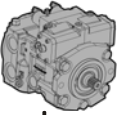

Brake inching (only for PM50)

The PM50 with Hydraulic automotive control D (page 37) can be provided with the B1/B2 brake inching. Its function is to reduce the displacement of pump. Reduction is achieved via brake pedal (connected to Z port). The pedal type VB3-010 (only inching function or inching and service brake function) can be provided upon request.



B1 Hydraulic inching spring $\varnothing 1,3$ mm [dia. 0.05 in]

B2 Hydraulic inching spring $\varnothing 1,5$ mm [dia. 0.06 in]

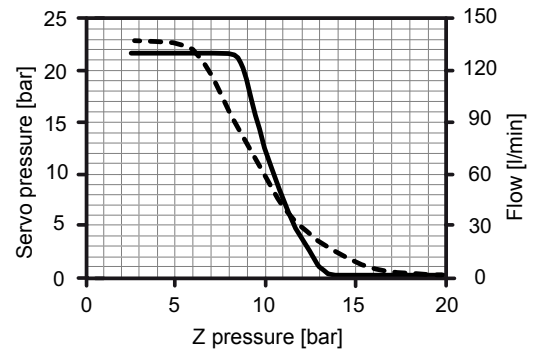
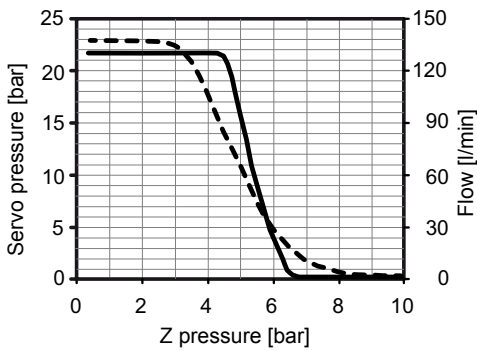

— Flow
 - - - Servo pressure

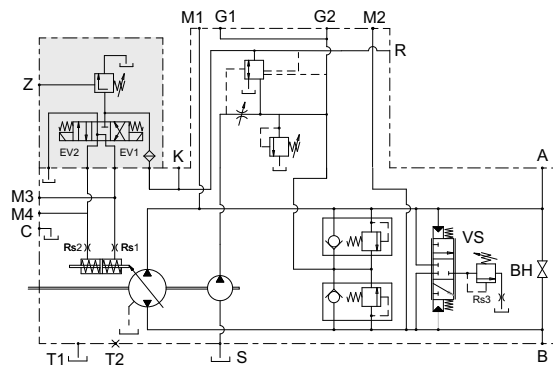
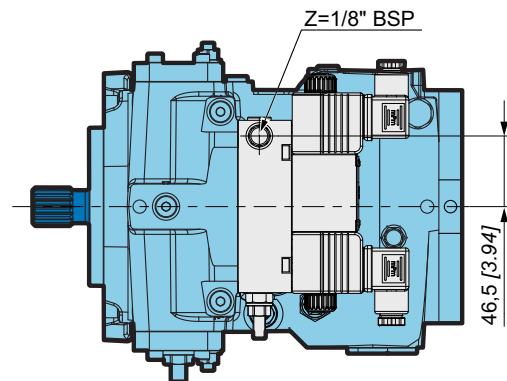
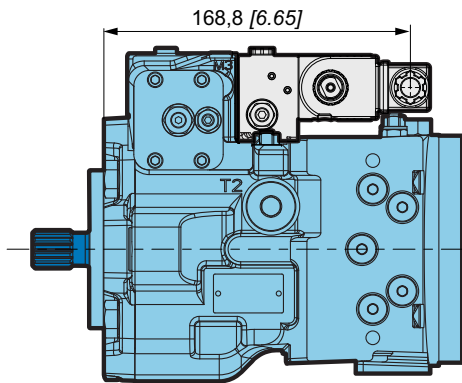

Solenoids specification

Operating voltage	12 VDC \pm 10%	24 VDC \pm 10%
Current	1500 mA	750 mA
Resistance at 20°C [68°F]	5,3 Ω \pm 7%	21,2 Ω \pm 7%
Connector type	DIN 43650	
Power	27 W	
Type of protection	IP65	
Mass	0,215 kg [0.47 lb]	



The hydraulic inching valve B1/B2 does not provide any sealing between closed loop circuit and pilot circuit. When choosing this function please be sure that oil to pilot the inching is coming from the same tank as the closed loop.

Model code

Technical specifications

Operating parameters

System parameters

Features

Controls

PMe package

PMe installation

Options

Appendixes

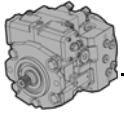

Brake inching (for PM50)

The PM50 with Hydraulic automotive control D (page 37) can be provided with the B5 brake inching. Its function is to reduce the displacement of pump. Reduction is achieved via brake pedal (connected to Z port) by means of brake fluid from the vehicle braking system. The pedal type VB3-010 (only inching function or inching and service brake function) can be provided upon request.

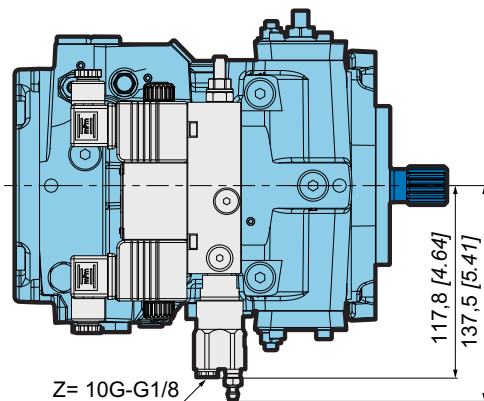
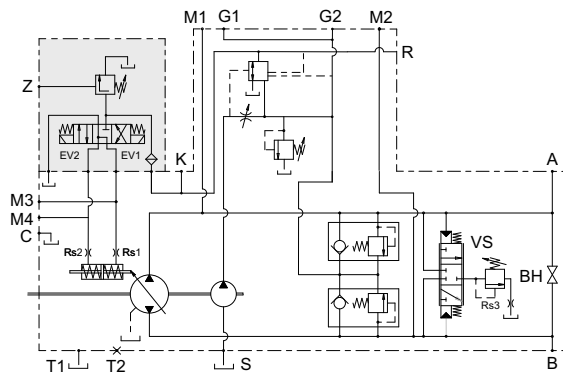
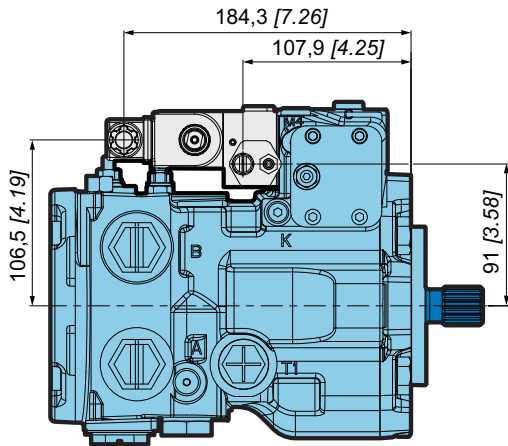
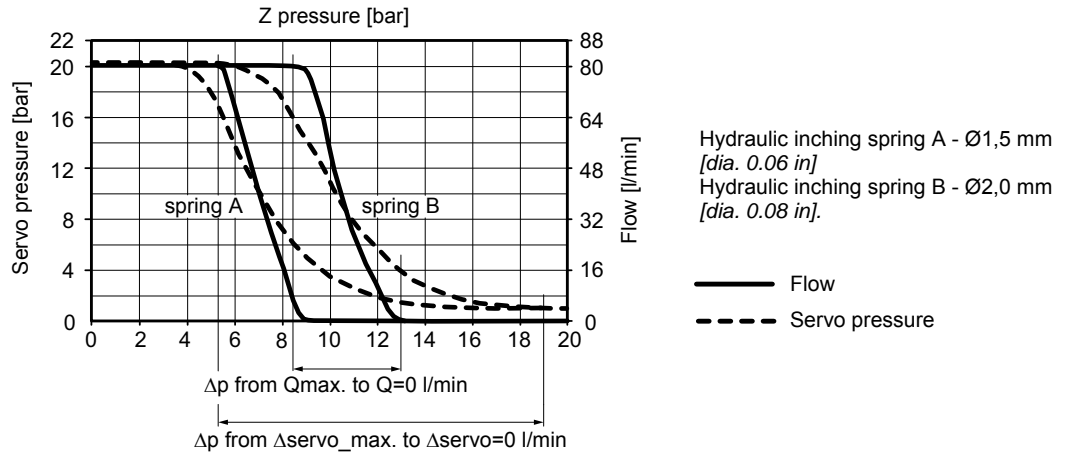

Solenoids specification

Operating voltage	12 VDC ± 10%	24 VDC ± 10%
Current	1500 mA	750 mA
Resistance at 20°C [68°F]	5,3 Ω ± 7%	21,2 Ω ± 7%
Connector type	DIN 43650	
Power	27 W	
Type of protection	IP65	
Mass	0,215 kg [0.47 lb]	



The hydraulic inching valve B5 provides sealing between closed loop circuit and pilot circuit.

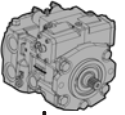

Anti-stall valve (for PM/PMe50)



The PM/PMe50 can be provided with anti-stall valve SD. It consists a cartridge valve (same cartridge valve as automotive control) which provides a pressure signal for the servo piston of the pump related to the speed of engine. Its function is to reduce pressure for servo piston in case of engine overload and consequent rpm reduction. As a result the pump de-strokes with an anti-stall effect.



For application of this option please contact your Poclain Hydraulics application engineer.

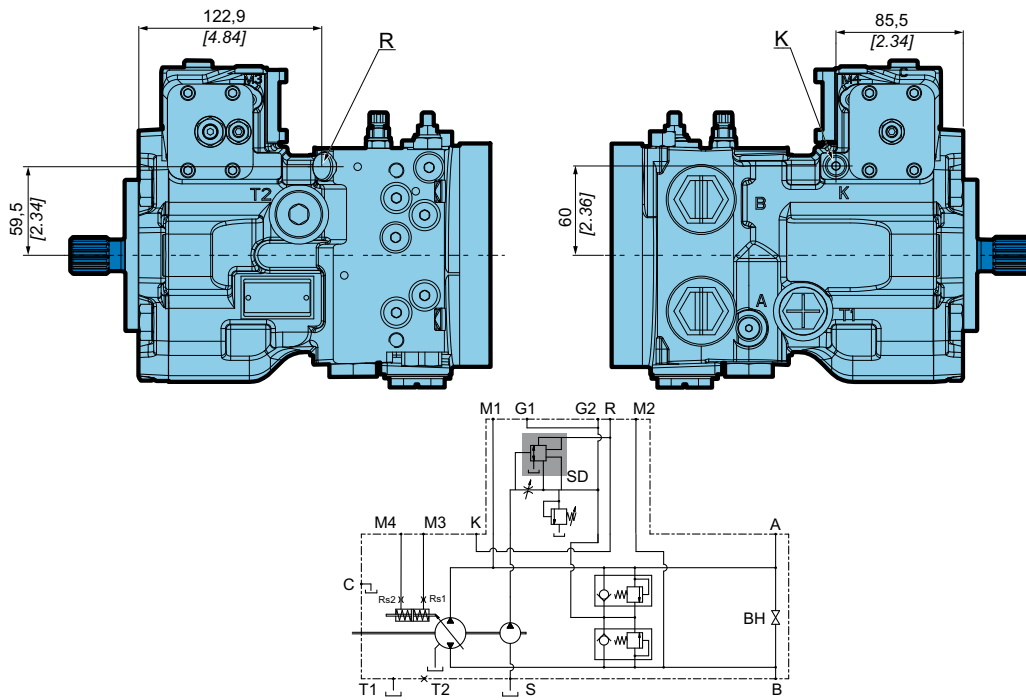

Temperature sensor (for PM/PMe50)



The PM/PMe50 can be provided with analog temperature sensor.

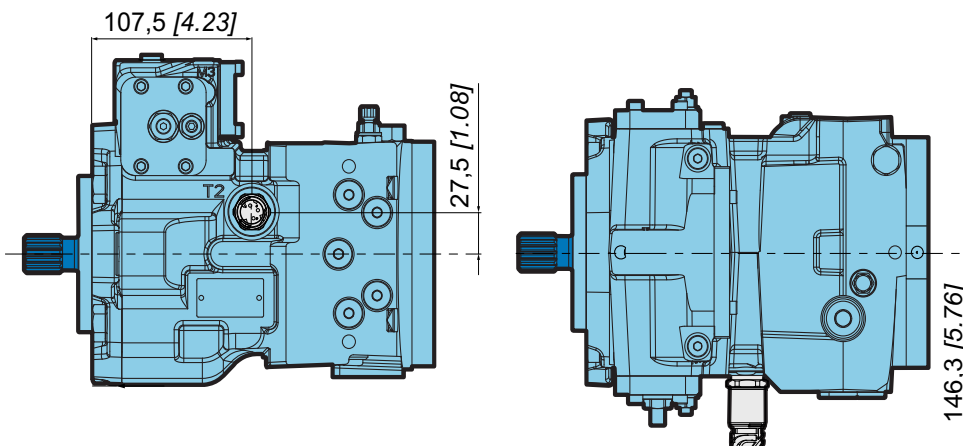

Model code

Technical specifications

Operating parameters

System parameters

Features

Controls

PMe package

PMe installation

Options

Appendix

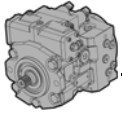

See the Mobile Electronics No. A01889D technical catalogue for the sensor specifications and its connection.



To install the sensor, see the Installation guide brochure No. B61352L.

Temperature sensor specification

Commercial name	TEMP-SENSOR-G1/4-DIN-7
Part number	B31477N
Compatibility	Electronic transmission management
Fonction	Measure the temperature of the hydraulic circuit

Features	
Power supply	5V ± 0.5 V
Output signal	0.5 V to 4.5 V radiometric Saturation at 0.4 V for temperatures < -23°C [-9.4°F]
Response time	4s for 50°C [122°F] step 8s for 90°C [122°F] step
Accuracy	±1.5% FS
Permissible pressure	600 bar [8 702 PSI]
Using temperature range	Medium: -40 to +120°C [-4 to +248°F] Ambient: -40 to +100°C [-4 to +212°F] Storage: -40 to +100°C [-4 to +212°F]
Housing material	Stainless steel 1,4571
Ingress protection	IP6K9K
Electrical protection	- Over voltage: 14V - Reverse polarity, - Against short circuits (0V and Vs)

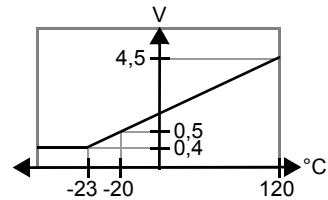

Pressure sensors on A&B lines (only for PMe50)



The PMe50 can be provided with two 600 bar [8 702 PSI] pressure sensors on A and B lines.

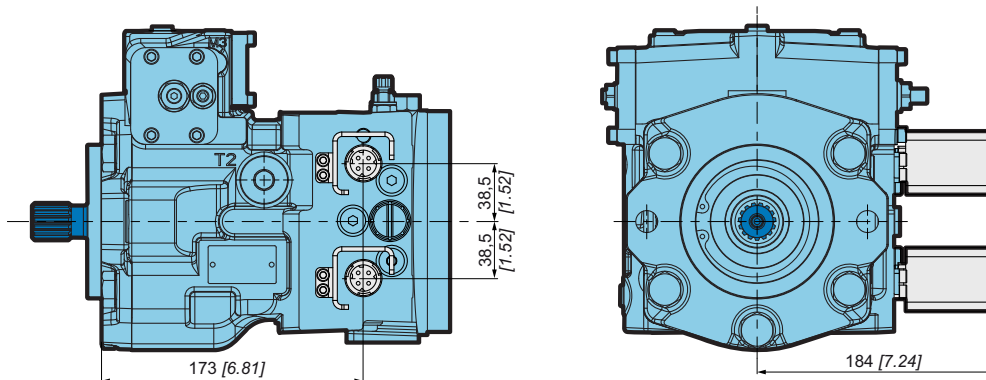

See the Mobile Electronics No. A01889D technical catalogue for the sensor specifications and its connection.

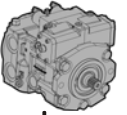

To install the sensor, see the Installation guide brochure No. B61352L.

Pressure sensor specification

Commercial name	PRES-SENS-600B-G1/4-DIN
Part number	B58371V
Compatibility	Electronic transmission management
Features	
Power supply (Ub)	5V DC ± 5%
Output signal	10% ... 90% (0.5V ... 4,5V at Ub=5V DC)
Pressure range	> 5k Ohm
Over pressure safety	1200 bar [17 404 PSI]
Pressure connection with VITON rectangular seal	G1/4A (DIN 3852-E)
Response time	calibrated 1 ms
Accuracy	< 1%
Using temperature range	Ambient: -40 to +105°C [-40 to +221°F] Storage: -40 to +100°C [-40 to +212°F] Medium: -40 to +125°C [-40 to +257°F]
Ingress protection	IP6K9K
CE conformity	EN 61000-6-1/2/3/4
Electrical protection	Overvoltage: +28,8V Polarity inversion: -5,2V Against short circuits (GND and Ub)
Shock resistance	500 g (DIN EN 60068-2-27)
Vibration resistance	25 g (IEC 60068-2-6, from 10 to 500 Hz)

Model code

Technical specifications

Operating parameters

System parameters

Features

Controls

PMe package

PMe installation

Options

Appendixes

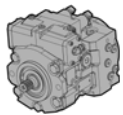

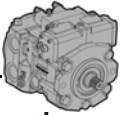

APPENDIXES

CAN messages from command device option

Name	Identifier (Hex)	Byte	Bit	Comment/Parameter	SPN	Length or resolution	Operating data range	
BJM1 0C FD D6 xx (P=3 PGN= 64982 SA=xxh)		1	1-2	Joystick 1 X-Axis neutral position status	2675	2 bits	00b = Not in neutral position 01b = In neutral position 10b = Error indicator 11b = Not available	
			3-4	Joystick 1 X-Axis lever left negative position status	2670	2 bits	00b = Not on negative side of neutral 01b = On negative side of neutral 10b = Error indicator 11b = Not available	
		2	5-6	Joystick 1 X-Axis lever right positive position status	2665	2 bits	00b = Not on positive side of neutral 01b = On positive side of neutral 10b = Error indicator 11b = Not available	
			7-8	Joystick 1 X-Axis position (LSB)	2660	10 bits	0,1%/bit, 0 offset	0,0 to 100 % 1022d = error 1023d = signal not available
			Joystick 1 X-Axis position (MSB)					
		3	1-2	Joystick 1 Y-Axis neutral position status	2676	2 bits	00b = Not in neutral position 01b = In neutral position 10b = Error indicator 11b = Not available	
			3-4	Joystick 1 Y-Axis lever back negative position status	2671	2 bits	00b = Not on negative side of neutral 01b = On negative side of neutral 10b = Error indicator 11b = Not available	
			5-6	Joystick 1 Y-Axis lever forward positive position status	2666	2 bits	00b = Not on negative side of neutral 01b = On negative side of neutral 10b = Error indicator 11b = Not available	
			7-8	Joystick 1 Y-Axis position (LSB)	2661	10 bits	0,1%/bit, 0 offset	0,0 to 100% 1022d = Error 1023d = Signal not available
		4	Joystick 1 Y-Axis position (MSB)					
		5	1-2	Not used				
			3-4	Not used				
			5-6	Not used				
			7-8	Not used				
		6	1-2	Not used				
			3-4	Not used				
			5-6	Not used				
			7-8	Not used				
		7	1-2	Not used				
			3-4	Not used				
5-6	Not used							
7-8	Not used							
8	1-2	Not used						
	3-4	Not used						
	5-6	Not used						
	7-8	Not used						

Model code

Technical specifications

Operating parameters

System parameters

Features

Controls

PMe package

PMe installation

Options

Appendixes

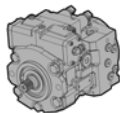

Name	Identifier (Hex)	Byte	Bit	Comment/Parameter	SPN	Length or resolution	Operating data range
BJM2 0C FD D8 xx (P=3 PGN= 64984 SA=xxh)	1	1-2		Joystick 1 X-Axis neutral position status	2675	2 bits	00b = Not in neutral position 01b = In neutral position 10b = Error indicator 11b = Not available
		3-4		Joystick 1 X-Axis lever left negative position status	2670	2 bits	00b = Not on negative side of neutral 01b = On negative side of neutral 10b = Error indicator 11b = Not available
		5-6		Joystick 1 X-Axis lever right positive position status	2665	2 bits	00b = Not on positive side of neutral 01b = On positive side of neutral 10b = Error indicator 11b = Not available
		7-8		Joystick 1 X-Axis position (LSB)	2660	10 bits 0,1%/bit, 0 offset	0,0 to 100 % 1022d = Error 1023d = signal not available
	2		Joystick 1 X-Axis position (MSB)				
	3	1-2		Joystick 1 Y-Axis neutral position status	2676	2 bits	00b = Not in neutral position 01b = In neutral position 10b = Error indicator 11b = Not available
		3-4		Joystick 1 Y-Axis lever back negative position status	2671	2 bits	00b = Not on negative side of neutral 01b = On negative side of neutral 10b = Error indicator 11b = Not available
		5-6		Joystick 1 Y-Axis lever forward positive position status	2666	2 bits	00b = Not on negative side of neutral 01b = On negative side of neutral 10b = Error indicator 11b = Not available
		7-8		Joystick 1 Y-Axis position (LSB)	2661	10 bits 0,1%/bit, 0 offset	0,0 to 100% 1022d = Error 1023d = Signal not available
	4		Joystick 1 Y-Axis position (MSB)				
	5	1-2		Not used			
		3-4		Not used			
		5-6		Not used			
		7-8		Not used			
	6	1-2		Not used			
		3-4		Not used			
		5-6		Not used			
		7-8		Not used			
	7	1-2		Not used			
		3-4		Not used			
5-6			Not used				
7-8			Not used				
8	1-2		Not used				
	3-4		Not used				
	5-6		Not used				
	7-8		Not used				

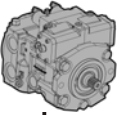

Name	Identifier (Hex)	Byte	Bit	Comment/Parameter	SPN	Length or resolution	Operating data range	
BJM3 0C FD DA xx (P=3 PGN= 64986 SA=xxh)		1	1-2	Joystick 1 X-Axis neutral position status	2675	2 bits	00b = Not in neutral position 01b = In neutral position 10b = Error indicator 11b = Not available	
			3-4	Joystick 1 X-Axis lever left negative position status	2670	2 bits	00b = Not on negative side of neutral 01b = On negative side of neutral 10b = Error indicator 11b = Not available	
			5-6	Joystick 1 X-Axis lever right positive position status	2665	2 bits	00b = Not on positive side of neutral 01b = On positive side of neutral 10b = Error indicator 11b = Not available	
			7-8	Joystick 1 X-Axis position (LSB)	2660	10 bits 0,1%/bit, 0 offset	0,0 to 100 % 1022d = Error 1023d = Signal not available	
		2	Joystick 1 X-Axis position (MSB)					
		3	1-2	Joystick 1 Y-Axis neutral position status	2676	2 bits	00b = Not in neutral position 01b = In neutral position 10b = Error indicator 11b = Not available	
			3-4	Joystick 1 Y-Axis lever back negative position status	2671	2 bits	00b = Not on negative side of neutral 01b = On negative side of neutral 10b = Error indicator 11b = Not available	
			5-6	Joystick 1 Y-Axis lever forward positive position status	2666	2 bits	00b = Not on negative side of neutral 01b = On negative side of neutral 10b = Error indicator 11b = Not available	
			7-8	Joystick 1 Y-Axis position (LSB)	2661	10 bits 0,1%/bit, 0 offset	0,0 to 100% 1022d = Error 1023d = Signal not available	
		4	Joystick 1 Y-Axis position (MSB)					
		5	1-2	Not used				
			3-4	Not used				
			5-6	Not used				
			7-8	Not used				
		6	1-2	Not used				
			3-4	Not used				
			5-6	Not used				
			7-8	Not used				
		7	1-2	Not used				
			3-4	Not used				
5-6	Not used							
7-8	Not used							
8	1-2	Not used						
	3-4	Not used						
	5-6	Not used						
	7-8	Not used						

- Model code
- Technical specifications
- Operating parameters
- System parameters
- Features
- Controls
- PMe package
- PMe installation
- Options
- Appendixes

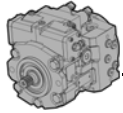

CAN Bus J1939 standard

This function builds CAN Bus frames following J1939 standard and puts these frames on the bus. These frames can be read by customer's CAN bus display. These frames are sent each 40ms ne frame, so 5 frames are repeated each 200ms. Sending of these frames can be disabled/ enabled by parameter "CAN_J1939".

PH SPN	Signal Name	Representation	Length	Limits (Range)	Notes
0	Pump1 Command	H	2 bytes	0 to 65535 cc	
1	Pump2 Command	H	2 bytes	0 to 65535 cc	Not used
2-4	Reserved				
5	Pump1 flow	A	3 bytes	0 to 838860,8 L/h 0 to 13981,01 L/min	
6	Pump2 flow	A	3 bytes	0 to 838860,8 L/h 0 to 1981,01 L/min	Not used
7-9	Reserved				
10	Pump1 speed	D	2 bytes	0 to 8191,87 rpm	
11	Pump2 speed	D	2 bytes	0 to 8191, 87 rpm	Not used
12-14	Reserved				
15-19	Reserved				
20	Driver command	B	1 byte	-100 to 100 %	
21-24	Reserved				
25	Brake command	B	1 byte	-100 to 100 %	
26-29	Reserved				
30	Inching command	B	1 byte	-100 to 100 %	
31-34	Reserved				
35-39	Reserved				
40	High pressure A	C	2 bytes	0 to 1 048 560 kPa 0 to 10 485,6 bar	
41	High pressure B	C	2 bytes	0 to 1 048 560 kPa 0 to 10 485,6 bar	
42-49	Reserved				
50	Machine speed measured		2 bytes	0 to 255,99 km/h	Not used
51	Machine speed flow	G	2 bytes	0 to 255,99 km/h	
52-59	Reserved				
60	Mode	J	4 bits	Transmission: 0 = Neutral 1 = Work mode 2 = Road mode Assist: 0 = Freewheel 1 = Assist 2 = Creep CDM: 0 = Freewheel 1 = Creep	Not used
61	Actual gear	E	4 bits	0 = Undefined 1 = Gear 1 2 = Gear 2 ... 15 = Gear 15	Not used
62	Direction F/N/R	I	2 bits	0 = Neutral 1 = Forward 2 = Reverse 3 = Not available	
63	Limp mode code	K	1 byte	0 to 255	Not used
64	Limp mode activation	I	2 bits	0 = Not Active 1 = Active 2 = Not defined 3 = Not available	Not used
65	Power level 1	F	2 bytes	0 to 32 767,5 kW	
66	Power level 2	F	2 bytes	0 to 32 767,5 kW	
67-69	Reserved				

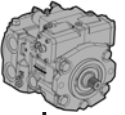

PH SPN	Signal Name	Representation	Length	Limits (Range)	Notes
70	Power limitation 1 activated	I	2 bits	0 = Not active 1 = Active 2 = Not defined 3 = Not available	
71	Power limitation 2 activated	I	2 bits	0 = Not active 1 = Active 2 = Not defined 3 = Not available	
72-74	Reserved				
75	Pressure limiter 1 activated	I	2 bits	0 = Not active 1 = Active 2 = Not defined 3 = Not available	
76	Pressure limiter 2 activated	I	2 bits	0 = Not active 1 = Active 2 = Not defined 3 = Not available	
77-79	Reserved				
80	Torque limitation 1 activated	I	2 bits	0 = Not active 1 = Active 2 = Not defined 3 = Not available	Not used
81	Torque limitation 2 activated	I	2 bits	0 = Not active 1 = Active 2 = Not defined 3 = Not available	Not used
82-84	Reserved				
85	Antistall activated	I	2 bits	0 = Not active 1 = Active 2 = Not defined 3 = Not available	
86	Engine overspeed activated	I	2 bits	0 = Not active 1 = Active 2 = Not defined 3 = Not available	
87	Speed loop activated	I	2 bits	0 = Not active 1 = Active 2 = Not defined 3 = Not available	
88	Temperature security status	I	2 bits	0 = Not active 1 = Active 2 = Not defined 3 = Not available	
89	Reserved				
90	Active error codes every n seconds the SmartDrive will shift this value to the next active error code	K	1 byte	0 = No error 1-255 = Active Error code	
91	PDU1 Format frame command		1 byte	1 = cf message PHR_1	

PGN definitions

Name	Identifier (Hex)	Byte	Bit	Comment/Parameter	PH SPN	Length of resolution	Operating data range	Notes
PH_1	18 FF 80 xx (P=6 PGN = 65408 SA = xxh)	1-2		Pump1 Command	0	1 cc/bit	0 to 65 535 cc	
		3-5		Pump1 flow	5	0.05 L/h per bit	0 to 838 860,8 L/h	
		6-7		Pump1 speed	10	0.125 rpm/bit	0 to 8 191,87 rpm	
		8		Not used			0xFF	
PH_2	18 FF 81 xx (P=6 PGN = 65409 SA = xxh)	1-2		Pump2 Command	1	1 cc/bit	0 to 65 535 cc	Not used
		3-5		Pump2 flow	6	0.05 L/h per bit	0 to 838 860,8 L/h	Not used
		6-7		Pump2 speed	11	0.125 rpm/bit	0 to 8 191,87 rpm	Not used
		8		Not used			0xFF	

Model code
Technical specifications
Operating parameters
System parameters
Features
Controls
PMe package
PMe installation
Options
Appendixes

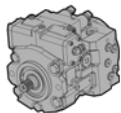

Name	Identifier (Hex)	Byte	Bit	Comment/ Parameter	PH SPN	Length of resolution	Operating data range	Notes
PH_3	18 FF 82 xx (P=6 PGN = 65410 SA = xxh)	1		Driver command	20	0.8 %/bit offset: -100%	-100 to 100%	
		2		Brake command	25	0.8 %/bit offset: -100%	-100 to 100%	
		3		Inching command	30	0.8 %/bit offset: -100%	-100 to 100%	Not used
		4	1-2	Power limitation 1 activated	70	2 bits	0 = Not active 1 = Active 2 = Not defined 3 = Not available	
		4	3-4	Power limitation 2 activated	71	2 bits	0 = Not active 1 = Active 2 = Not defined 3 = Not available	
		4	5-6	Pressure limitation 1 activated	75	2 bits	0 = Not active 1 = Active 2 = Not defined 3 = Not available	
		4	7-8	Pressure limitation 2 activated	76	2 bits	0 = Not active 1 = Active 2 = Not defined 3 = Not available	
		5	1-2	Torque limitation 1 activated	80	2 bits	0 = Not active 1 = Active 2 = Not defined 3 = Not available	Not used
		5	3-4	Torque limitation 2 activated	81	2 bits	0 = Not active 1 = Active 2 = Not defined 3 = Not available	Not used
		5	5-6	Antistall activated	85	2 bits	0 = Not active 1 = Active 2 = Not defined 3 = Not available	Not used
		5	7-8	Engine overspeed activated	86	2 bits	0 = Not active 1 = Active 2 = Not defined 3 = Not available	
		6	1-2	Speed loop activated	87	2 bits	0 = Not active 1 = Active 2 = Not defined 3 = Not available	
		6	3-4	Temperature security status	88	2 bits	0 = Not active 1 = Active 2 = Not defined 3 = Not available	
		6	5-6	Not used		2 bits	11b	
		6	7-8	Not used		2 bits	11b	
		7		Active error codes	90	1 byte	0 = No error 1-255 = active error code	
		8		Not used			0xFF	

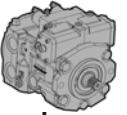

Name	Identifier (Hex)	Byte	Bit	Comment/Parameter	PH SPN	Length of resolution	Operating data range	Notes
PH_4	18 FF 83 xx (P=6 PGN = 65411 SA = xxh)	1-2		Machine speed measured	50	1/256 km/h per bit	0 to 255,99 km/h	Not used
		3-4		Machine speed flow	51	1/256 km/h per bit	0 to 255,99 km/h	
		5	1-4	Mode	60	4 bits	Transmission: 0 = Neutral 1 = Work mode 2 = Road mode Assist: 0 = Freewheel 1 = Assist 2 = Creep CDM: 0 = Freewheel 1 = Creep	Not used
		5-8	Actual gear	61	4 bits	0 = Undefined 1 = Gear 1 2 = Gear 2 ... 15 = Gear 15	Not used	
		6	1-2	Direction (F/N/R)	62	2 bits	0 = Neutral 1 = Forward 2 = Reverse 3 = Not available	
		3-4	Limp mode activated	64	2 bits	0 = Not active 1 = Active 2 = Not defined 3 = Not available	Not used	
		5-8	Not used		4 bits	1111b		
		7	Limp mode code	63	8 bits	0 to 255	Not used	
		8	Not used			0xFF		
		PH_5	18 FF 84 xx (P=6 PGN = 65412 SA = xxh)	1-2		High pressure A	40	16 kPa/bit
3-4				High pressure B	41	16 kPa/bit	0 to 1 048 560 kPa 0 to 10 485,6 bar	
5-6				Power level 1	65	0.5 kW/bit	0 to 32 767,5 kW	
7-8				Power level 2	66	0.5 kW/bit	0 to 32 767,5 kW	

- Model code
- Technical specifications
- Operating parameters
- System parameters
- Features
- Controls
- PMe package
- PMe installation
- Options
- Appendixes

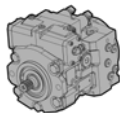

Details of CAN messages for CAN slave

INPUTS (Master to PMe pump):

POCLAIN HYDRAULICS PUMP COMMAND#1 (PHPC1) - PGN 61184

(Transmission rate: 10 - 100ms):

Name	Identifier (Hex)	Byte	Bit	Comment/Parameter	SPN	Length or resolution	Operating data range
PHPC1 18 EF yy xx (P=6 PGN=61184 DA = yyh SA = xxh)		1		Data index		1 byte	01h = pump command
		2	1-2	Pump direction		2 bits	00b = Neutral 01b = Direction A 10b = Direction B 11b = Not defined (Neutral)
			3-4	Pump enable		2 bits	00b = Not activated 01b = Activated 10b = Not defined (Not activated) 11b = Not defined (Not activated)
			5-8	Not used	N/A		1111b
			3-4	Pump command		2 bytes 1/10 th cc	0.0 to 6553.4 cc
			5-6	Not used		2 bytes	FFFFh
			7	Not used		1 byte	FFh
			8	Command message counter		1 byte	0 to 255



In the following message, the ~ means Complement to 1.
For example: ~ PHPC1.byte8 = 0xFF - PHPC1.byte8.

POCLAIN HYDRAULICS PUMP COMMAND#2 (PHPC2) - PGN 61184

(Transmission rate: 10 - 100ms):

Name	Identifier (Hex)	Byte	Bit	Comment/Parameter	SPN	Length or resolution	Operating data range
PHPC2 18 EF yy xx (P6=6 PGN= 61184 DA = yyh SA = xxh)		1		Data index		1 byte	02h = pump command redundancy
		2		Data index		1 byte	= ~PHPC1.byte8
		3		Redundant signal		1 byte	= ~PHPC1.byte7
		4		Redundant signal		1 byte	= ~PHPC1.byte6
		5		Redundant signal		1 byte	= ~PHPC1.byte5
		6		Redundant signal		1 byte	= ~PHPC1.byte4
		7		Redundant signal		1 byte	= ~PHPC1.byte3
		8		Redundant signal		1 byte	= ~PHPC1.byte2

- For those messages DA value comes from "Own J1939 address in Slave" parameter.
- For those messages SA value comes from "J1939 address of commander" parameter.



Care must be taken to compute PHPC2 message using the same input values than PHPC1.

Example of CAN messages:

Pump commanded in direction A:

	0.005004	18EF1FEx	PHPC1	Tx	8	01 F5 00 00 FF FF FF A1
	0.005048	18EF1FEx	PHPC2	Tx	8	02 5E 00 00 FF FF FF 0A

Pump commanded in direction A @2.1cc:

	0.005108	18EF1FEx	PHPC1	Tx	8	01 F5 15 00 FF FF FF E3
	0.005401	18EF1FEx	PHPC2	Tx	8	02 1C 00 00 00 FF EA 0A

Pump commanded in direction A @3.2cc:

	0.006000	18EF1FEx	PHPC1	Tx	8	01 F6 20 00 FF FF FF 2D
	0.004028	18EF1FEx	PHPC2	Tx	8	02 D2 00 00 00 FF DF 09

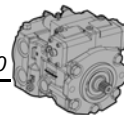

OUTPUTS (PMe pump to Master)

POCLAIN HYDRAULICS PUMP INFO#1 (PHPI1) - PGN 65386
 (Transmission rate: 10 - 100ms [parameter, 100 ms by default]):

Name	Identifier (Hex)	Byte	Bit	Comment/Parameter	SPN	Length or resolution	Operating data range
PHPI1	18 FF6Axx (P=6 PGN=65386 SA = xxh)	1-2		Pump displacement		2 bytes 1/10th cc	0.00 to 6553.4 cc FFFFh = N/A
		3-4		Pump feedback voltage		2 bytes mV	0.000 to 5200 mV FFFFh = N/A
		5-6		Drift voltage		bool	-5200 to 5200 mV offset: RAW = mV + 5200 FFFFh = N/A
		7	1	Pump enabled <i>isPumpOK()</i> & <i>pumpEnable_received</i>		bool	0b = Pump disabled 1b = Pump enabled
		2		S1 connector error		bool	0b = Cnx OK 1b = Cnx fault
		3		S2 connector error		bool	0b = Cnx OK 1b = Cnx fault
		4		Cut-off connector error		bool	0b = Cnx OK 1b = Cnx fault
		5		By-pass connector error		bool	0b = Cnx OK 1b = Cnx fault
		6		Loop error		bool	0b = Error not active 1b = Error active
		7		Drift error		bool	0b = Error not active 1b = Error active
		8		FB error		bool	0b = Error not active 1b = Error active
		8	1	Pollution		bool	0b = No pollution 1b = Pollution
		2		General safe state		bool	0b = NoGSS 1b = GSS
		3-4		Pump direction		2 bits	0b = Neutral 01b = Direction A 10b = Direction B 11b = Not defined (Neutral)
		5		Initial frame received	N/A		0b = Frame not received 1b = Frame was received
6		Communication error flag	N/A		0b = Error not active 1b = Error active		
7		Not used	N/A		1b		
8		Not used	N/A		1b		

POCLAIN HYDRAULICS PUMP INFO#2 (PHPI2) - PGN 65387
 (Transmission rate: 10 - 100ms [parameter, 100ms by default]):

Name	Identifier (Hex)	Byte	Bit	Comment/Parameter	SPN	Length or resolution	Operating data range
PHPI2	18 F6Bxx (P6=6 PGN= 65387 SA = xxh)	1-2		Power supply		2 bytes 1mV/bit	0000 to 32 000 mV FFFFh = N/A
		3-4		5V supply output		2 bytes 1mV/bit	000000 to 5500 mV FFFFh = N/A
		5-6		Max. pump displacement		2 bytes 1/10th cc	0.0 to 6553.4 cc FFFFh = N/A
		7-8		Not used		2 bytes	FFFFh

• For those messages SA value comes from "Own J1939 address in Slave" parameter

Model code

Technical specifications

Operating parameters

System parameters

Features

Controls

PMe package

PMe installation

Options

Appendixes

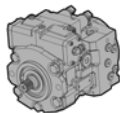

Other available outputs

The pump can be equipped with sensors (temperature, pressure and speed). Their value will be sent on the CAN bus.

Two types of information on the CAN bus exist:

- Physical value (in V or Hz)
- Calculated value (in Bar or RPM or °C)

If the sensor voltage is out of valid range (0.5V - 4.5V), calculated value will be FFFFh. There is no management for sensors.

With Phases™ you have possibility to modify temperature and pressure parameters for sensors (Bar/Volt, Degree/Volt ...)

POCLAIN HYDRAULICS PUMP INFO#3 (PHPI3) - PGN 65388

(Transmission rate: 10 - 100ms [parameter, 100ms by default]):

Name	Identifier (Hex)	Byte	Bit	Comment/Parameter	SPN	Length or resolution	Operating data range
PHPI3	18 FF6Cxx (P=6 PGN= 65388 SA = xxh)	1-2		HPA pressure sensor voltage		2 bytes 1mV/bit	0000 to 5200 mV
		3-4		HPA pressure sensor		2 bytes 16 kPa/bit	000000 to 100 000 kPa FFFFh = Signal not present
		5-6		HPB pressure sensor voltage		2 bytes 1 mV/bit	0000 to 5 200 mV
		7-8		HPB pressure sensor		2 bytes 16kPa/bit	000000 to 100 000 kPa FFFFh = Signal not present

POCLAIN HYDRAULICS PUMP INFO#4 (PHPI4) - PGN 65389

(Transmission rate: 10 - 100ms [parameter, 100ms by default]):

Name	Identifier (Hex)	Byte	Bit	Comment/Parameter	SPN	Length or resolution	Operating data range
PHPI3	18 FF6Dxx (P=6 PGN= 65389 SA = xxh)	1-2		Speed sensor frequency		2 bytes - 0,15 Hz/bit	0000 to 8 500 Hz
		3-4		Speed sensor		2 bytes - 0,125 RPM/bit	0000 to 5 000 RPM
		5-6		Temperature sensor voltage		2 bytes - 1 mV/bit	0000 to 5 000 mV FFFFh = Signal not present
		7-8		Temperature sensor		1 byte -1°C/bit	-40 °C to +210 °C offset: RAW = x°C + 40 FFFFh = Signal not present
		8		Not used		1 byte	FFh

- For those messages SA value comes from "Own J1939 address in Slave" parameter.

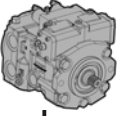

Model code

Technical specifications

Operating parameters

System parameters

Features

Controls

PMe package

PMe installation

Options

Appendixes

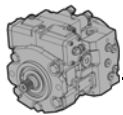

Variable displacement pump PM/PMe50

POCLAIN HYDRAULICS

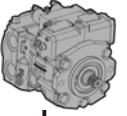

Model code

Technical specifications

Operating parameters

System parameters

Features

Controls

PMe package

PMe installation

Options

Appendixes

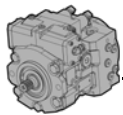

Variable displacement pump PM/PMe50

POCLAIN HYDRAULICS

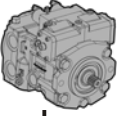

Model code

Technical specifications

Operating parameters

System parameters

Features

Controls

PMe package

PMe installation

Options

Appendixes



Poclain Hydraulics reserves the right to make any modifications it deems necessary to the products described in this document without prior notification. The information contained in this document must be confirmed by Poclain Hydraulics before any order is submitted.

Illustrations are not binding.

The Poclain Hydraulics brand is the property of Poclain Hydraulics S.A.

 05/03/2020

 Not available

 B08353D

 Not available

 Not available

 Not available

 B33979H

 Not available

 Not available

