

NEW

DVS series

Sectional Valves



DVS series

Sectional Valves



The DVS Series directional valves are a new family of sectional valves specifically designed for several applications: Forestry Machines, Skid Steer Loaders and Mini Dumper, Cranes, Wheel Loaders, Backhoe Loaders, Garbage Compactors, Hook and Skip Loaders, Drilling Rigs and Forklifts.

The valves have very exact control characteristics and they are smooth and precise in operation, with compact light weight design. These valves are available in several configurations and custom solutions.

Working sections have auxiliary valves and a wide range of interchangeable spools.

The DVS valves can be fitted with integrated proportional electrohydraulic controls.

		WORKING CONDITIONS		
		DVS10	DVS14	DVS16
Nominal flow rating	Standard	45 l/min - 12 US gpm	80 l/min - 21 US gpm	160 l/min - 42 US gpm
	For flow unloader	-	120 l/min - 32 US gpm	200 l/min - 53 US gpm
Max. pressure		350 bar - 5100 psi	350 bar - 5100 psi	(P) 305 bar - 4400 psi (A-B) 350 bar - 5100 psi
	With mechanical devices	20 bar - 290 psi	20 bar - 290 psi	20 bar - 290 psi
Back pressure (max.) on T outlet port	With hydraulic and pneumatic devices	20 bar - 290 psi	20 bar - 290 psi	20 bar - 290 psi
	With electrohydraulic devices	-	10 bar - 145 psi	10 bar - 145 psi
Internal leakage A(B)⇒T (standard)	$\Delta p = 100 \text{ bar} / 1450 \text{ psi}$	5 cm ³ /min - 0.30 in ³ /min	8 cm ³ /min - 0.49 in ³ /min	10 cm ³ /min - 0.61 in ³ /min
Fluid		Mineral oil-based		
Fluid temperature range	With NBR seals (BUNA-N)	from -20°C to 80°C from -4°F to 176°F	from -20°C to 80°C from -4°F to 176°F	from -20°C to 80°C from -4°F to 176°F
Viscosity	Operating range	from 10 to 300 mm ² /s from 10 to 300 cSt	from 10 to 300 mm ² /s from 10 to 300 cSt	from 10 to 300 mm ² /s from 10 to 300 cSt
Max. contamination level		-/19/16 - ISO 4406 NAS 1638 - class 10		
Environmental temperature for working conditions	All devices	from -40°C to 60°C from -40°F to 140°F	from -40°C to 60°C from -40°F to 140°F	from -40°C to 60°C from -40°F to 140°F
Tie rod tightening torque (wrench 13)		24.5 Nm - 18 lbft	40 Nm - 30 lbft	40 Nm - 30 lbft

NEW

DVS10 dimensional data

The DVS10 is designed for Mini Skid Steer Loaders and Mini Dumper applications. This valve is smooth and precise in operation with compact light weight design. Auxiliary valves and wide range of interchangeable spools are available.

The DVS10 valves may be ordered with right or left inlet; for more detailed information, please contact our Sales Dpt.

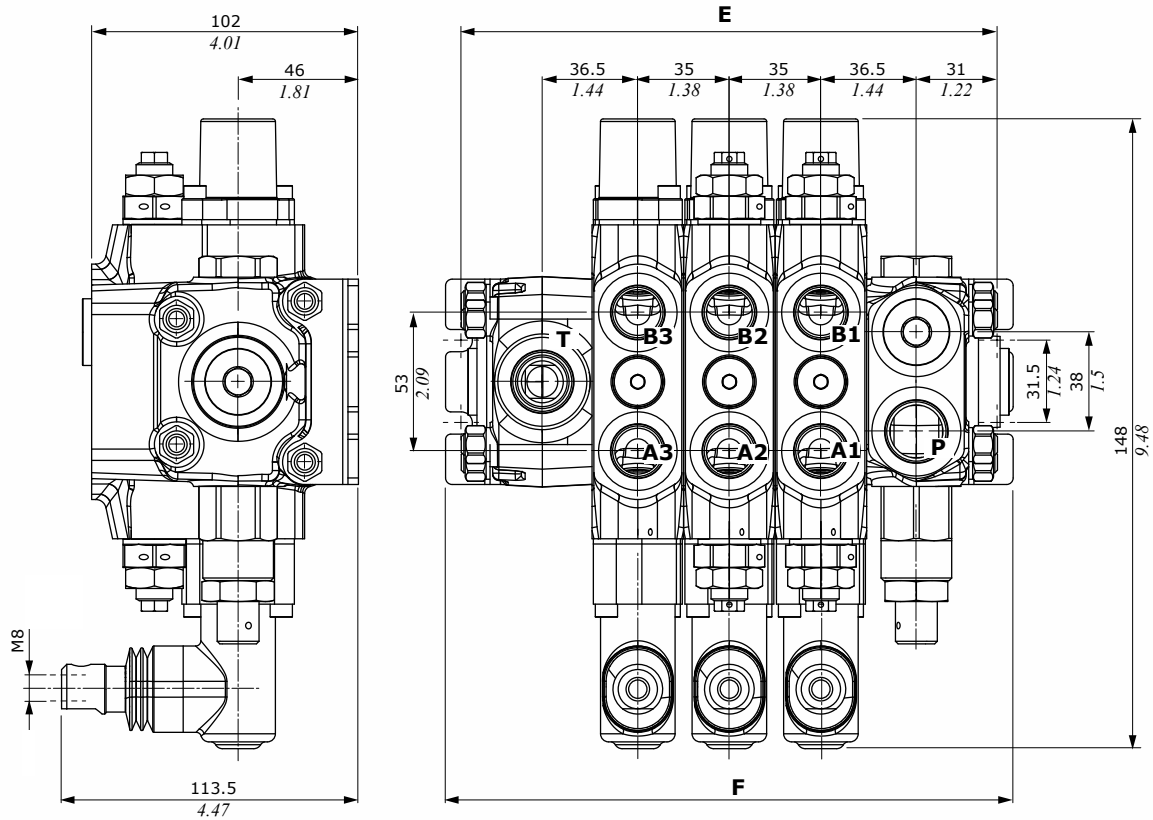

TYPE	E		F	
	mm	in	mm	in
DVS10/1	135	5.31	147	5.79
DVS10/2	170	6.69	182	7.16
DVS10/3	205	8.07	217	8.54
DVS10/4	240	9.45	252	9.92
DVS10/5	275	10.83	287	11.3
DVS10/6	310	12.2	322	12.68
DVS10/7	345	13.58	357	14.05
DVS10/8	380	14.96	392	15.43
DVS10/9	415	16.34	427	16.81
DVS10/10	450	17.72	462	18.19
DVS10/11	485	19.09	497	19.57
DVS10/12	520	20.47	532	20.94

PORT THREADING		
MAIN PORTS	BSP	UN-UNF
P inlet	G 3/8 - G 1/2	3/4-16 (SAE 8) - 7/8-14 (SAE 10)
A and B ports	G 3/8	3/4-16 (SAE 8)
T outlet and C carry-over	G 1/2	7/8-14 (SAE 10)
PILOT PORTS		
Hydraulic	G 1/4	9/16-18 (SAE 6)
Pneumatic	G 1/8	NPTF 1/8-27



DVS series

Sectional Valves

DVS10 hydraulic circuit

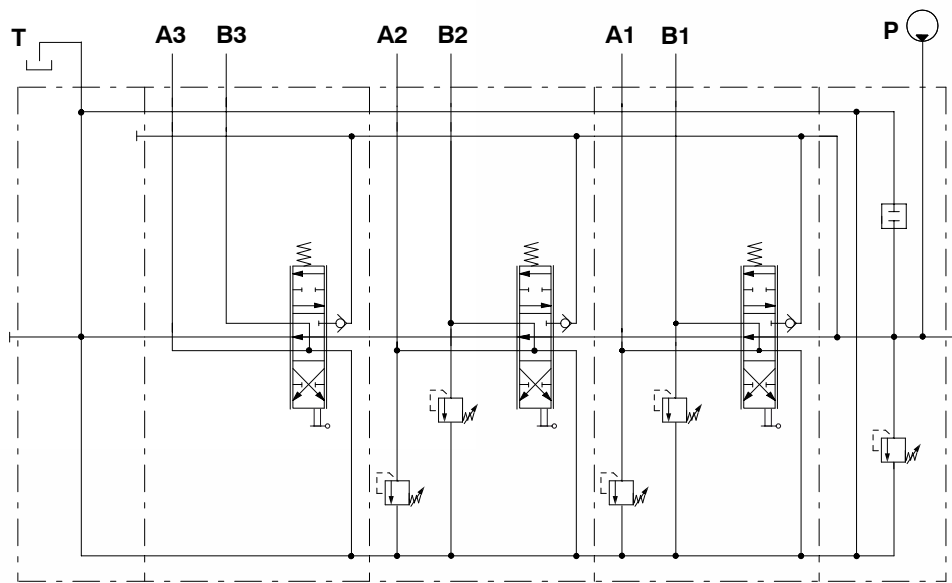

Description example with lever control configuration:

DVS10/3/IR001(205)-AG03/W002A-H001-F001A-RPG03-01TPA(140)-01TPB(140)/W002A-H001-F001A-RPG03-01TPA(140)-01TPB(140)/W002A-H001-F001A-RPG03/TJAG04

DVS10 performance data

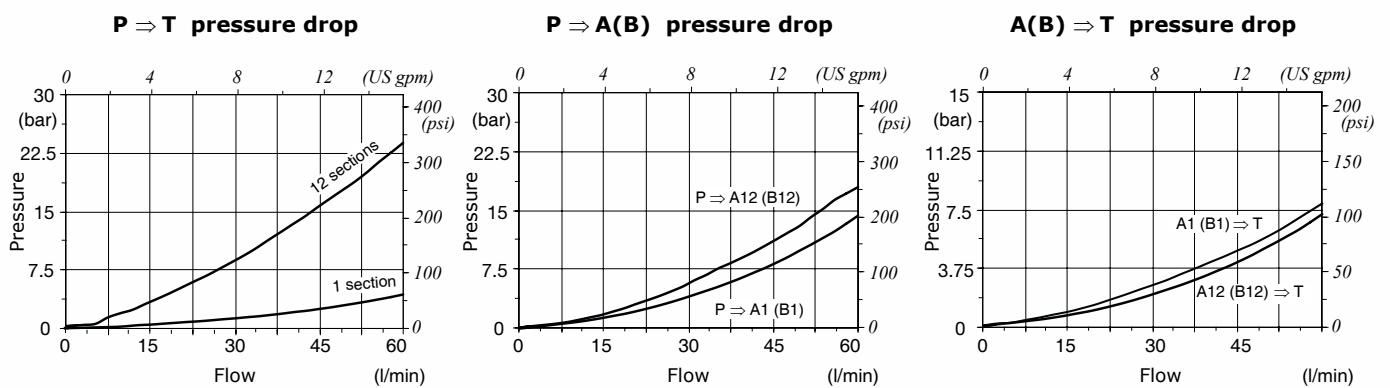

NEW

DVS10 complete section ordering codes

right inlet: R
left inlet: L
DVS10/3/IR001(205)-AG03/W002A-H001-F001A-RPG03-01PA(140)-01PB(140)/

Nr. of working
sections

1

2

W002A-H005-F001A-RPG03-01PA(140)-01PB(140)/W002A-H001-F001A-RPG03/TJAG04

2

2

3

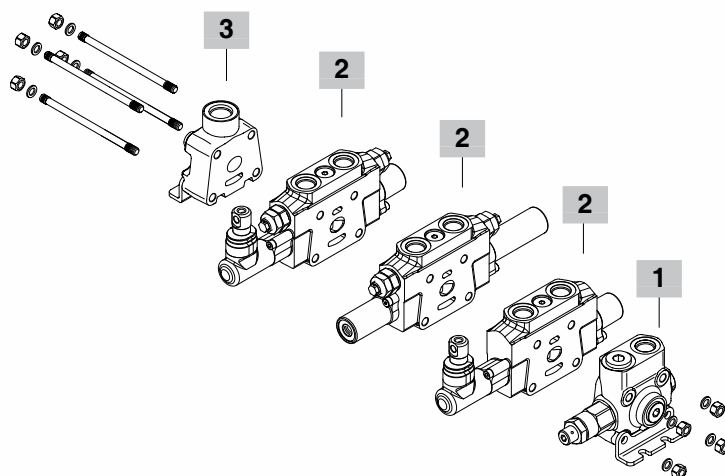

1 Complete inlet section

TYPE: **IR001(205)-AG03**

DESCRIPTION: Upper inlet (thread G 3/8) with direct acting pressure relief valves

TYPE: **IR019-EG03**

DESCRIPTION: Upper inlet and outlet (thread G 3/8) without valves

2 Complete working section

TYPE: **W002A-H001-F001A-RPG03-01PA-01PB**

DESCRIPTION: Parallel circuit arranged for port valves (ports plugged), 3 positions, lever control with spring return in neutral position

TYPE: **W002A-H001-F001A-RPG03**

DESCRIPTION: As previous without port valves

TYPE: **W002A-H005-RPG03-01PA-01PB**

DESCRIPTION: Parallel circuit without port valves, hydraulic control with spring return in neutral position

3 Complete outlet section

TYPE DESCRIPTION

TJAG04 Upper outlet section with single return (T)

TMWG04 Upper outlet section with two return (HPCO) carry-over

NOTES - The DVS10 valves are available with right or left inlet and with UN-UNF threading. For more detailed information, please contact our Sales Dpt.

DVS series

Sectional Valves

DVS14 dimensional data

The DVS14 directional valve is an Open Center sectional valve, that can be equipped with integrated proportional electrohydraulic controls. This product is indicated for several applications: Forestry Cranes, Truck Mounted Cranes, Wheel Loaders, Backhoe Loaders, Compactors, Hook and Skip Loaders, Forklifts. Its flexibility allows to match applications' different requirements and its easy assembly is appreciated by retail market. Available with Flow Unloader section.

The DVS14 valves are available with right or left inlet; for more detailed information, please contact our Sales Dpt.

The dimensions are referred to the electrohydraulic configuration.

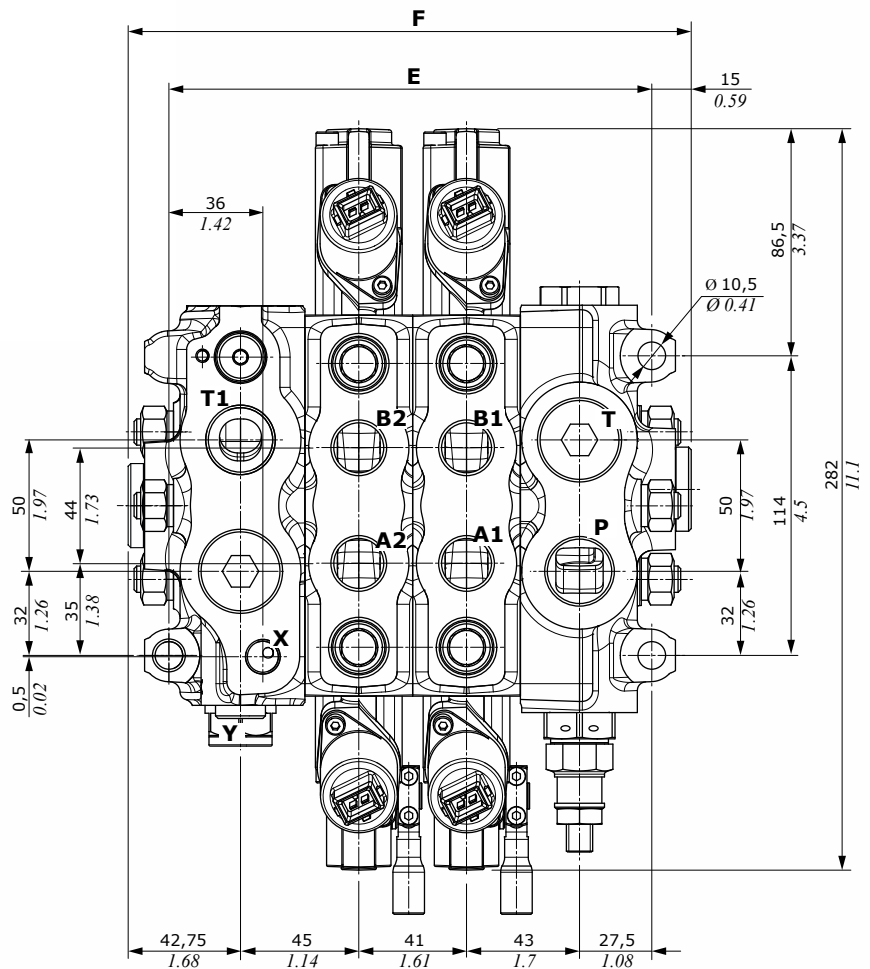
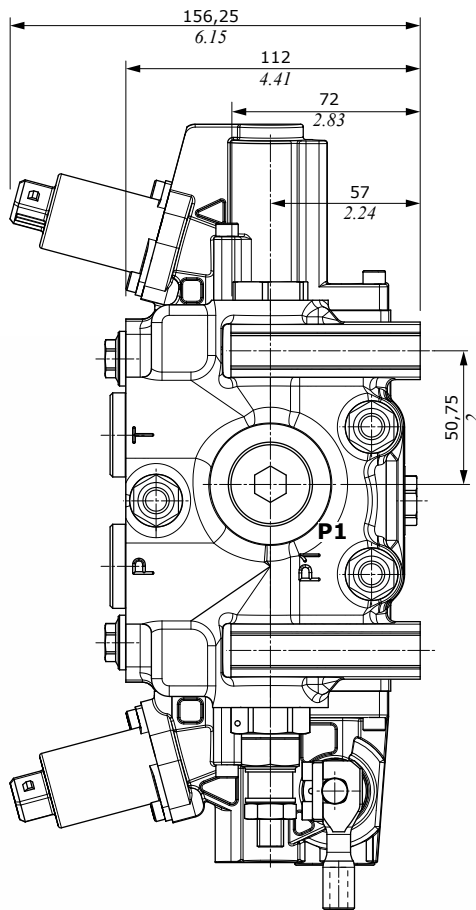

TYPE	E		F	
	mm	in	mm	in
DVS14/1	144	5.67	173,25	6.82
DVS14/2	185	7.28	214,25	8.42
DVS14/3	226	8.9	255,25	10.04
DVS14/4	267	10.5	296,25	11.66
DVS14/5	308	12.12	337,25	13.27
DVS14/6	349	13.7	378,25	14.9
DVS14/7	390	15.35	419,25	16.5
DVS14/8	431	16.96	460,25	18.12
DVS14/9	472	18.58	501,25	19.73
DVS14/10	513	20.2	542,25	21.34

PORT THREADING		
MAIN PORTS	BSP	UN-UNF
P inlet	G 1/2 - G 3/4	7/8-14 (SAE 10) - 1 1/6-12 (SAE 12)
A and B ports	G 1/2	3/4-16 (SAE 8)
T outlet and C carry-over	G 1/2 - G 3/4	7/8-14 (SAE 10) - 1 1/6-12 (SAE 12)
PILOT PORTS		
Hydraulic	G 1/4	9/16-18 (SAE 6)
Pneumatic	NPTF 1/8-27	NPTF 1/8-27

NEW

DVS14 hydraulic circuit

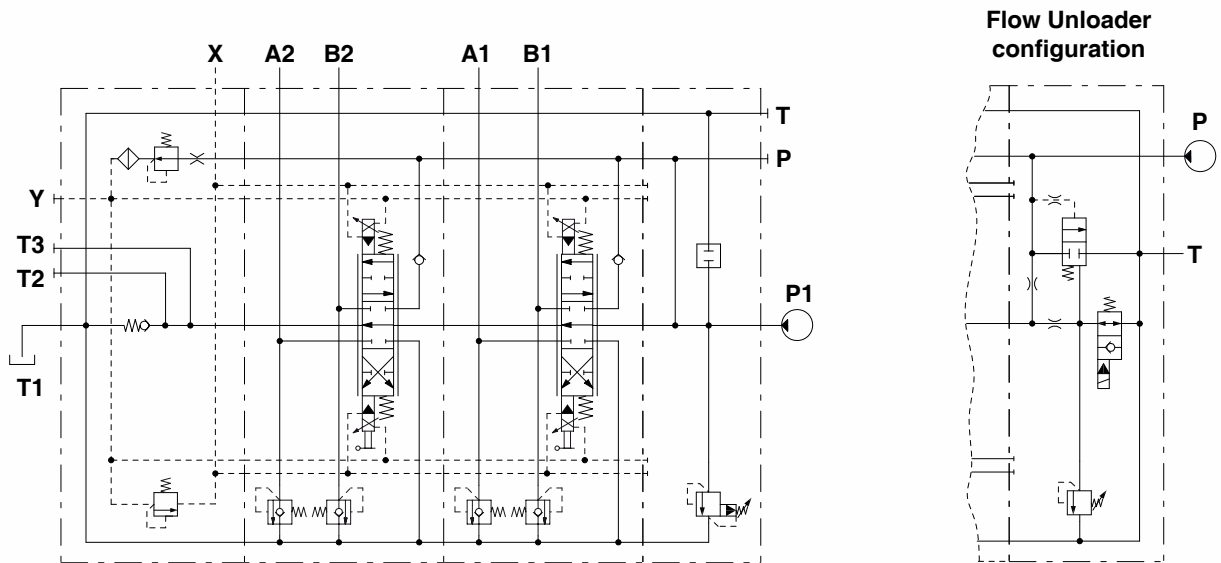

Description example with electrohydraulic configuration:

DVS14/2/MR-V2A(200)V7B-C12AJ-A-G05/W001A-HP04-FP04-B12AJ-RP1-G04.03TF-PA(100)\03TF-PB(100)/W001A-HP04-FP04-B12AJ-RP1-G04.03TF-PA(100)\03TF-PB(100)/KZP1-G05

DVS14 performance data

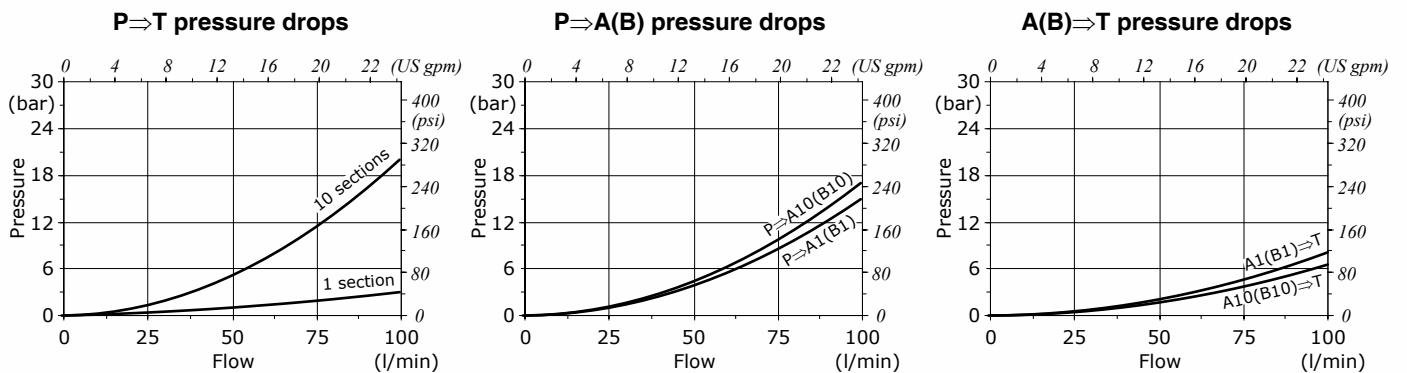

DVS series

Sectional Valves

DVS14 complete section ordering codes

right inlet: R
left inlet: L

Example with mechanical/hydraulic configuration

DVS14/1/MR-V2A(200)-V3B-A-G05/W001A-H001-F001A-RP1-G04.05TF-PA\05TF-PB/KZPM1-G05

Nr. of working sections: 1, 2, 3

right inlet: R
left inlet: L

Example with electrohydraulic configuration

**DVS14/2/MR-V2A(200)V3B-A-G05/W001A-HP04-FP04-B12AJ-RP1-G04.05TF-PA\05TF-PB/
W001A-HP04-FP04-B12AJ-RP1-G04.05TF-PA\05TF-PB/KZP1-G05**

Nr. of working sections: 1, 2, 3

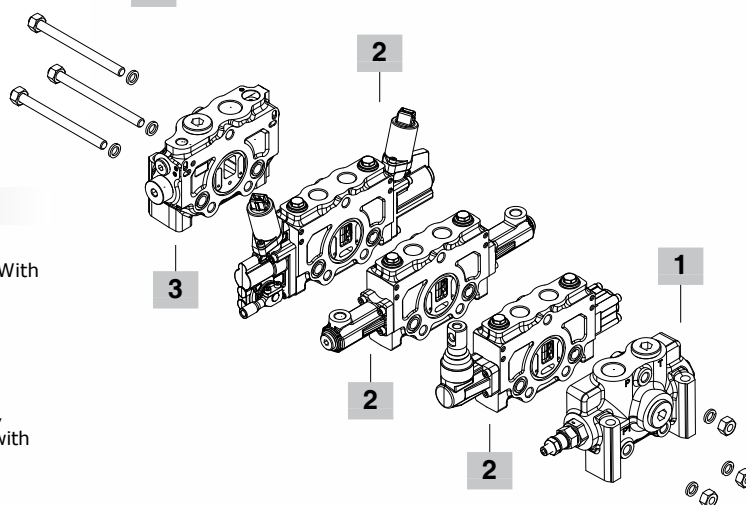

1 Complete inlet section

TYPE: **MR-V2A(200)-V3B-A-G05**

DESCRIPTION: Upper inlet, side inlet and upper outlet plugged. With pilot operated pressure relief valve.

TYPE: **MR-V3A-V3B-A-G05**

DESCRIPTION: Upper inlet, side inlet and upper outlet plugged. Without pilot operated pressure relief valve.

TYPE: **MRQ-V1A(200)-V7B-C12DI-MA-X-G05**

DESCRIPTION: For Flow Unloader configuration, with compensator, upper inlet and outlet, direct pressure relief valve, unloader valve with electric control 12VDC (connector AMP JPT)

2 Complete working section

TYPE: **SD\W001A-H001-F001A-RP1-G04.05TF-PA/05TF-PB**

DESCRIPTION: Parallel circuit arranged for port valves (ports plugged), 3 positions double acting spool, lever control with spring return in neutral position

TYPE: **SD\W001A-H001-F001A-RP2-G04**

DESCRIPTION: Parallel circuit without port valves, lever control with spring return in neutral position

TYPE: **SD\W001A-HP04-FP04-B12AJ-RP1-G04.05TF-PA/05TF-PB**

DESCRIPTION: Parallel circuit arranged for port valves (ports plugged), 3 positions double acting spool, electrohydraulic control 12VDC (connector AMP JPT) lever control with spring return in neutral position

TYPE: **SD\W001A-HP04-FP04-B12AJ-RP1-G04.05TF-PA/05TF-PB**

DESCRIPTION: As previous without port valves

TYPE: **SD\W001AQ-HP04-FP04-B12AJ-RP1-G04.05TF-PA/05TF-PB**

DESCRIPTION: For Flow Unloader configuration, parallel circuit arranged for port valves (ports plugged), 3 positions double acting spool, electrohydraulic control 12VDC (connector AMP JPT) lever control with spring return in neutral position

3 Complete outlet section

TYPE DESCRIPTION

For all control types, without pressure reducing valve

KZM1-G05 T1 port open, Y pilot and drain X plugged

KZMH1-G05 With carry-over (HPCO) on T1 port, Y pilot and drain X plugged

For electrohydraulic control, with pressure reducing valve

KZP1-G05 With backpressure valve, upper T1 port and X drain open, T2-T3 outlets and Y pilot plugged

KZPH1-G05 Without backpressure valve, carry-over (HPCO) on upper T2 port, upper T1 port and drain X open, side T3 port and Y pilot plugged

NOTES - The DVS14 valves are available with right or left inlet and with UN-UNF threading. For more detailed information, please contact our Sales Dpt.

NEW

DVS16 dimensional data

The DVS16 is a versatile, flexible sectional valve, that complete the DVS valves range. It combines the same features of DVS14 with flow up to 160 l/min (42 US gpm). Available with Flow Unloader section.

The DVS16 valves are available with right or left inlet; for more detailed information please, contact our Sales Dpt.

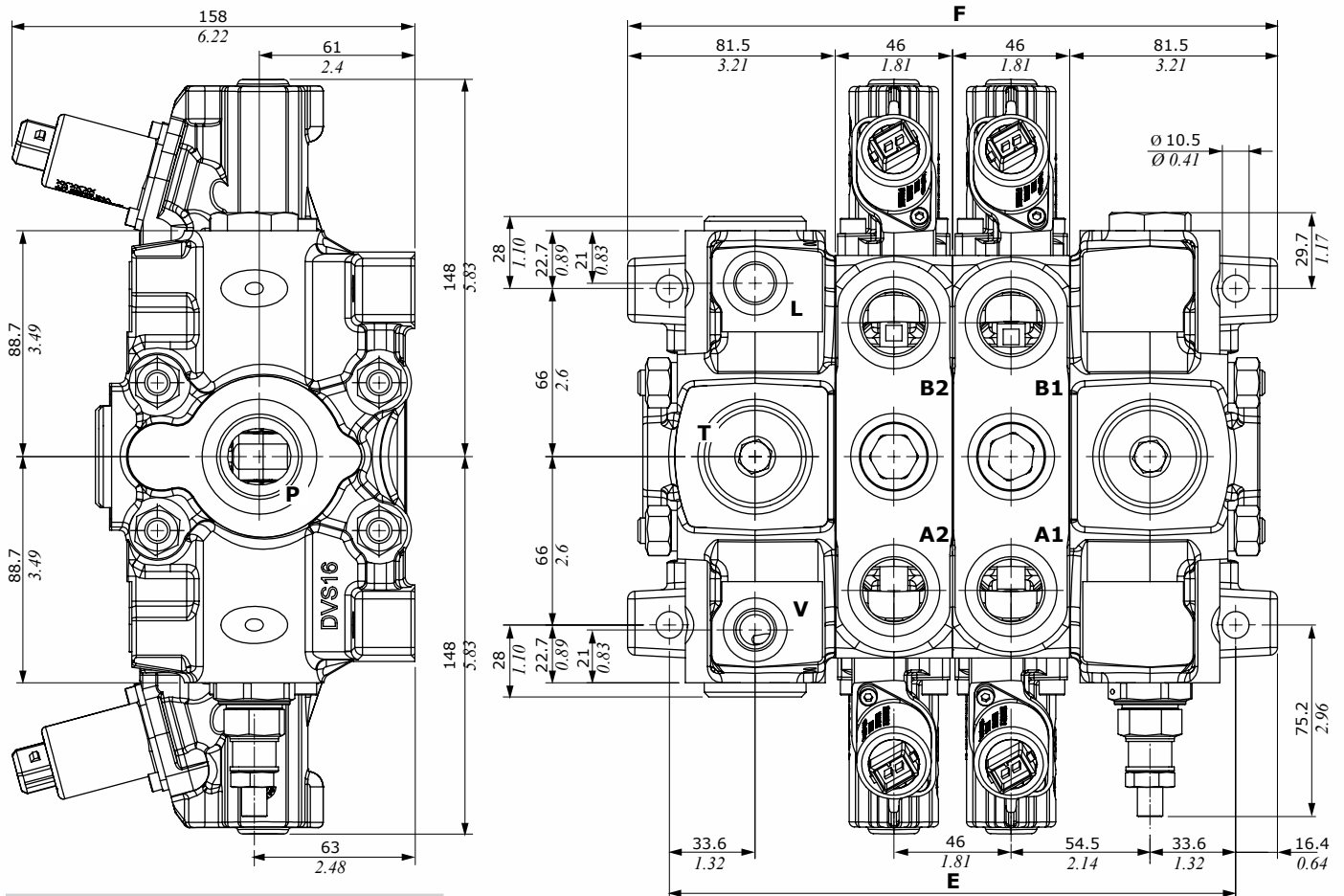

TYPE	E		F	
	mm	in	mm	in
DVS16/1	176.2	6.9	209	8.2
DVS16/2	222.2	8.7	255	10
DVS16/3	268.2	10.6	301	11.9
DVS16/4	314.2	12.4	347	13.7
DVS16/5	360.2	14.2	393	15.5
DVS16/6	406.2	16	439	17.3
DVS16/7	452.2	17.8	485	19.1
DVS16/8	498.2	19.6	531	20.9
DVS16/9	544.2	21.4	577	22.7
DVS16/10	590.2	23.2	623	24.5
DVS16/11	636.2	25	669	26.3
DVS16/12	682.2	26.9	715	28.1

	PORT THREADING	
	BSP	UN-UNF
P inlet	G 1	1 1/16-12 (SAE 12) 1 5/16-12 (SAE 16)
A and B ports	G 3/4	7/8-14 (SAE 10)
T outlet and C carry-over	G 1	1 1/16-12 (SAE 12) 1 5/16-12 (SAE 16)
M, L, V	G 1/4 - G 3/8	9/16-18 (SAE 6)

DVS series

Sectional Valves

DVS16 hydraulic circuit

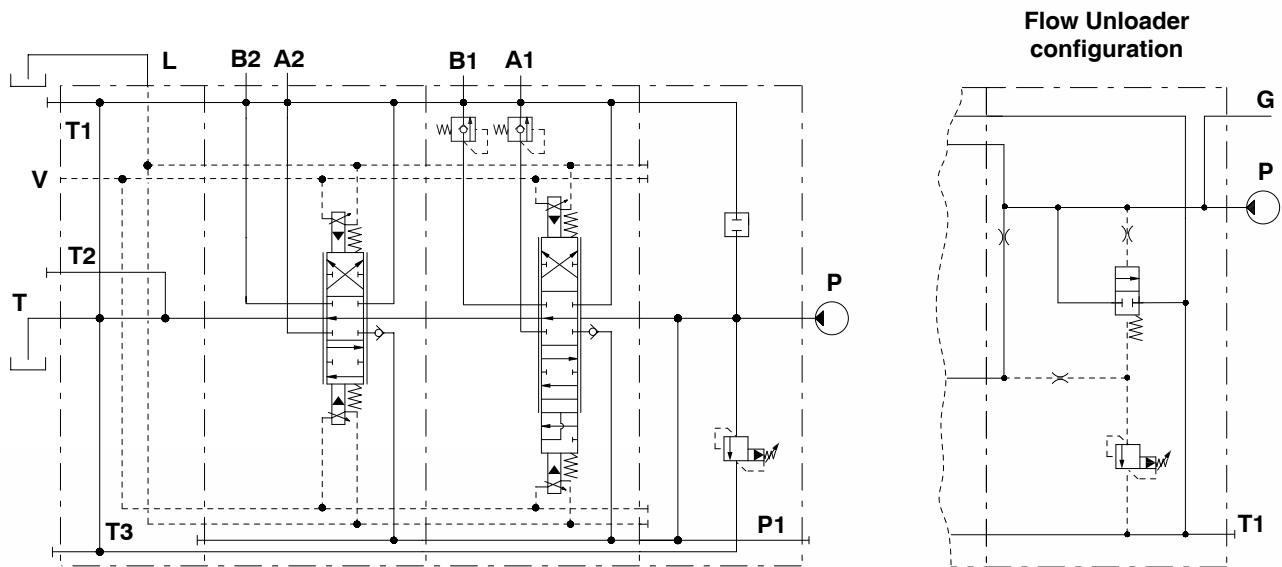

Example with electrohydraulic configuration:

DVS16/2/MR-V2A(180)-V3B-C-G06/W0012A-HP07-FP04-B24AJ-RP1-G05.03TF-PA(250)/
W001A-HP07-FP04-B24AJ-RP2-G05\03TF-PB(250)/KZP2-G06

DVS16 performance data

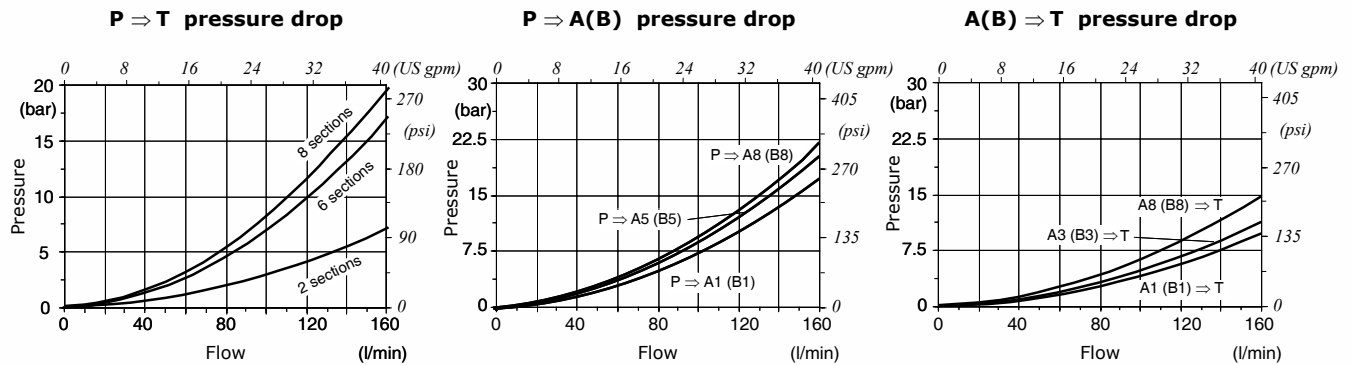

NEW

DVS16 complete section ordering codes

right inlet: R
left inlet: L

Example with mechanical/hydraulic configuration

DVS16/1/MR-V2A(200)-V3B-C-G06/W001A-H001-F001-RP1-G05.05TF-PA\05TF-PB/KZM1

Nr. of working sections: 1, 2, 3

right inlet: R
left inlet: L

Example with electrohydraulic configuration

DVS16/2/MR-V2A(200)V3B-A-G06/W001A-HP04-FP04-B12AJ-RP1-G05.05TF-PA\05TF-PB/

Nr. of working sections: 1, 2

W001A-HP04-FP04-B12AJ-RP1-G05.05TF-PA\05TF-PB/KZPR1-G06

2, 3

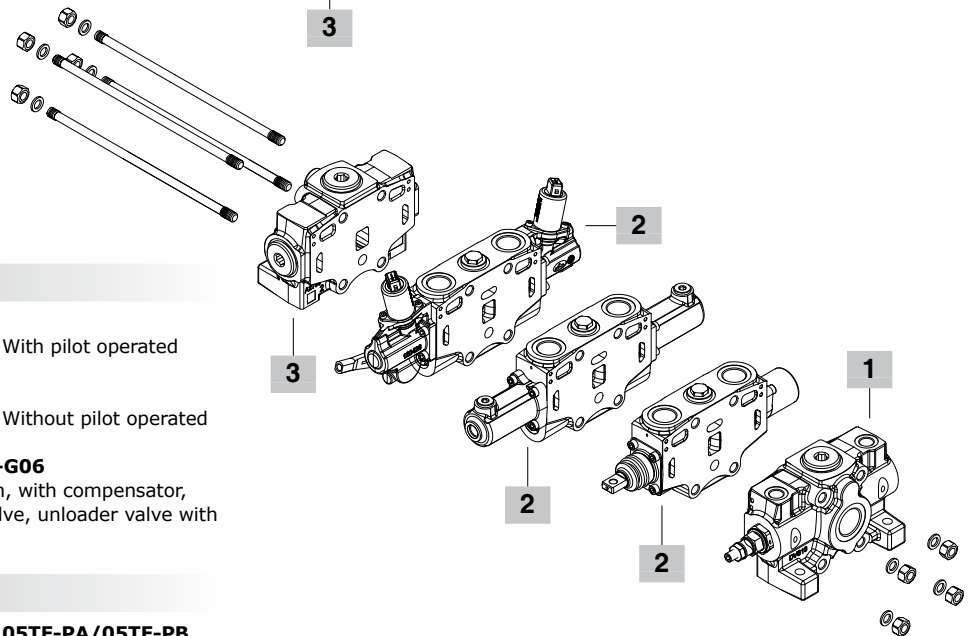

1 Complete inlet section

TYPE: **MR -V2A(200)-V3B-C-G06**

DESCRIPTION: Upper inlet, side inlet plugged. With pilot operated pressure relief valve.

TYPE: **MR-V3A-V3B-C-G06**

DESCRIPTION: Upper inlet, side inlet plugged. Without pilot operated pressure relief valve.

TYPE: **MRQ-V1A(200)-V7B-C12DI-A-MA-X-G06**

DESCRIPTION: For Flow Unloader configuration, with compensator, upper inlet and outlet, direct pressure relief valve, unloader valve with electric control 12VDC (connector AMP JPT)

2 Complete working section

TYPE: **SD\W001A-H001-F001A-RP1-G04A.05TF-PA/05TF-PB**

DESCRIPTION: Parallel circuit arranged for port valves (ports plugged), 3 positions double acting spool, lever control with spring return in neutral position

TYPE: **SD\W001A-H001-F001A-RP2-G05**

DESCRIPTION: Parallel circuit without port valves, lever control with spring return in neutral position

TYPE: **SD\W001A-HP04-FP04-B12AJ-RP1-G05.05TF-PA/05TF-PB**

DESCRIPTION: Parallel circuit arranged for port valves (ports plugged), 3 positions double acting spool, electrohydraulic control 12VDC (connector AMP JPT) lever control with spring return in neutral position

TYPE: **SD\W001A-HP04-FP04-B12AJ-RP1-G05.05TF-PA/05TF-PB**

DESCRIPTION: As previous without port valves

TYPE: **SD\W001AQ-HP04-FP04-B12AJ-RP1-G04.05TF-PA/05TF-PB**

DESCRIPTION: For Flow Unloader configuration, parallel circuit arranged for port valves (ports plugged), 3 positions double acting spool, electrohydraulic control 12VDC (connector AMP JPT) lever control with spring return in neutral position

3 Complete outlet section

TYPE	DESCRIPTION
KZM1	Configuration for mechanic/hydraulic controls, without pressure reducing valve and without backpressure valve, T upper port open
KZMH1	As previous, with carry-over (HPCO) on T port and T2 port open
KZP1	Configuration for electrohydraulic controls, without pressure reducing valve, T upper port, V pilot and L drain open
KZPR1	Configuration for electrohydraulic controls, with pressure reducing valve and backpressure valve, T upper port open, V pilot and L drain plugged

NOTES - The DVS16 valves are available with right or left inlet and with UN-UNF threading. For more detailed information, please contact our Sales Dpt.

 **walvoil**
FLUID POWER EMOTION



D1WHBCB02E - 1st edition October 2019

Walvoil S.P.A. • 42124 Reggio Emilia • Italy • Via Adige, 13/D • Tel. +39.0522.932411 • Fax +39.0522.300984
www.walvoil.com

