

V SERIES

HYDRAULIC MOTOR

HIGH TORQUE - LOW SPEED



TYPE		AVMP								
MOTOR SIZE		25	40	50	75	100	150	200	300	400
DISPLACEMENT	cm ³	25	40	49.5	79.2	99	158.4	198	316.8	396
	in ³	1.82	2.44	3.02	4.83	6.04	9.66	12.1	19.3	24.16
MAX. SPEED	rpm cont.	1600	1500	1210	755	605	378	303	190	150
	rpm int.	1815	1750	1515	945	755	472	378	236	189
MAX. TORQUE	Nm cont.	33	62	94	151	193	310	360	380	360
	lbf.in cont	290	550	835	1340	1710	2740	3180	3360	3180
	Nm int.	47	82	119	195	237	370	450	560	590
MAX. PRESSURE DROP	bar cont.	100	120	140	140	140	140	140	90	70
	psi cont.	1450	1750	2030	2030	2030	2030	2030	1300	1015
	bar int.	140	155	175	175	175	175	175	140	115
MAX. OIL FLOW	lpm cont.	40	60	60	60	60	60	60	60	60
	gpm cont.	8.8	13.2	13.2	13.2	13.2	13.2	13.2	13.2	13.2
	lpm int.	45	70	75	75	75	75	75	75	75
WEIGHT kg	AVMP & -4	5.9	6.0	6.1	6.2	6.3	6.5	6.8	7.2	7.5
	AVMP-RP & -4	6.3	6.4	6.5	6.6	6.7	6.9	7.2	7.6	7.9

Maximum inlet pressure 3250 psi - 224 bar
High pressure shaft seal drain line not required for most applications.

Maximum pressure drop and speed must not be reached simultaneously.
Intermittent operation may occur for 10% max. of every minute.

At speeds lower than 10 rpm please consult our Technical Department.

Mineral based hydraulic fluids with anti-wear additives are recommended with a viscosity of 35 mm²/s at a temperature of 50 C.

Minimum recommended oil viscosity 13 mm²/s at operating temperature.

Recommended oil cleanliness ISO 19/14 with a nominal filtration of 25 micron or better.

Where non-flammable fluids are to be used it is advisable to consult our Technical Department.

Ambient temperature should be between -30 C° and +90 C°

Normal operating temperature should be between +30 C° and +60 C°

Maximum operating temperature +85 C°

SYMBOL

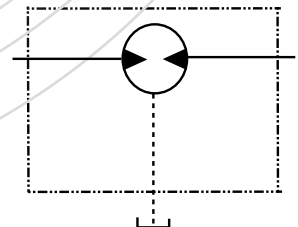

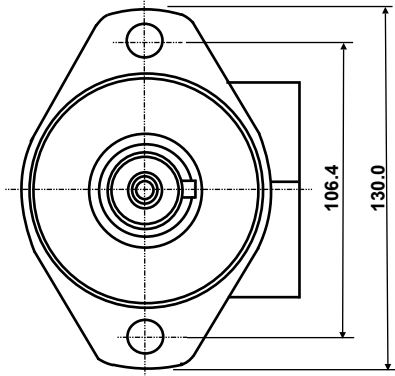

AVMP

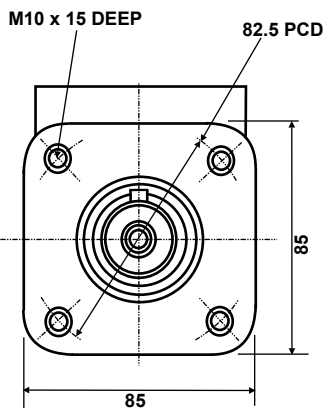
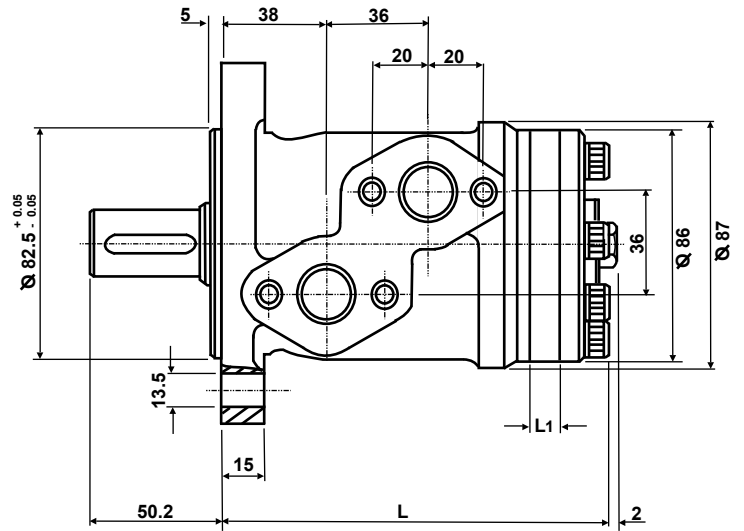

AVMP-4

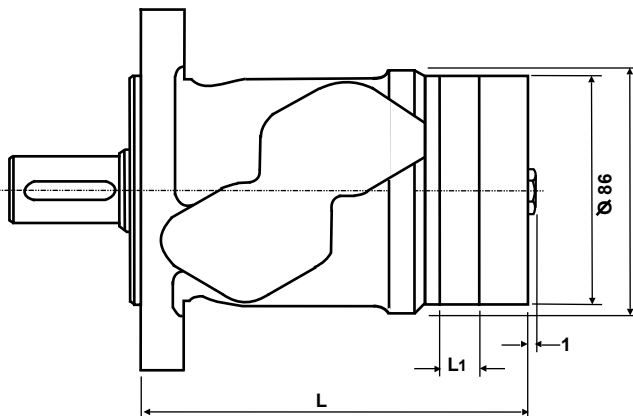
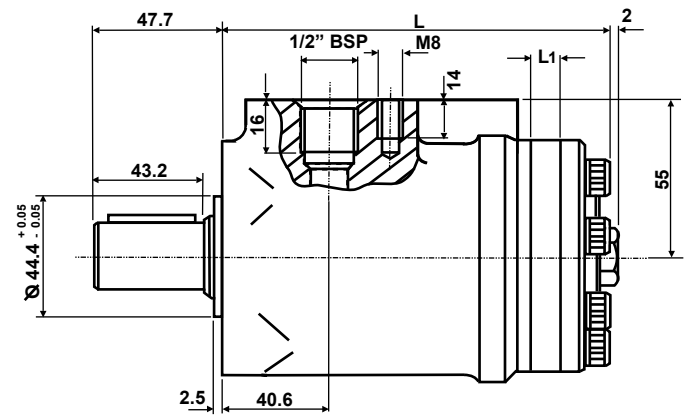

AVMP-RP

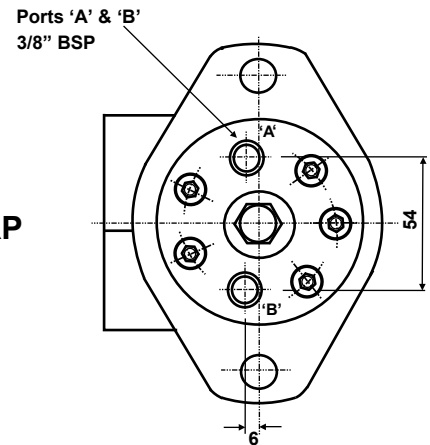

For performance graphs see V performance sheets

Motor size	Dimn.	25	40	50	75	100	150	200	300	400
ALL TYPES	L ₁	5.2	7.4	6.7	10.7	13.3	41.3	26.7	42.7	53.3
AVMP	L	132.5	134.7	134.0	138.0	140.6	148.6	154.0	170.0	180.6
AVMP-4	L	135.1	137.3	136.6	140.6	143.2	151.2	156.6	172.6	183.2
AVMP-RP	L	134.5	136.7	136.0	140.0	142.6	150.6	156.0	172.0	182.6
AVMP-4-RP	L	137.1	139.3	138.0	142.0	144.6	152.6	158.0	174.0	184.6

Metric Shaft - M

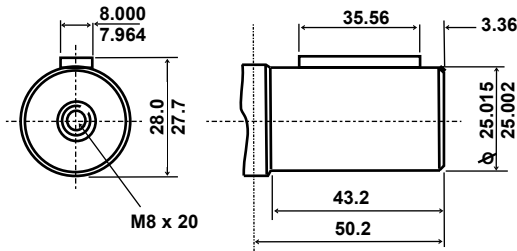

Imperial Shaft -

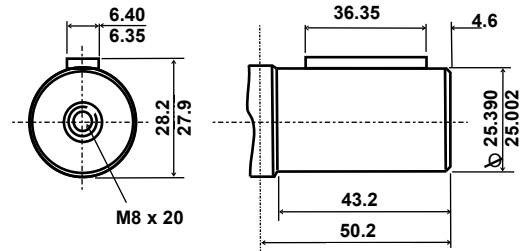

Splined Shaft - S

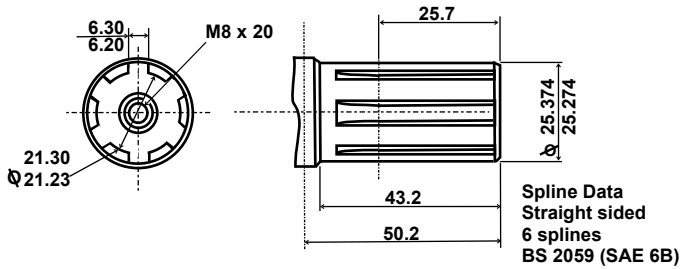

Tapered Shaft - T

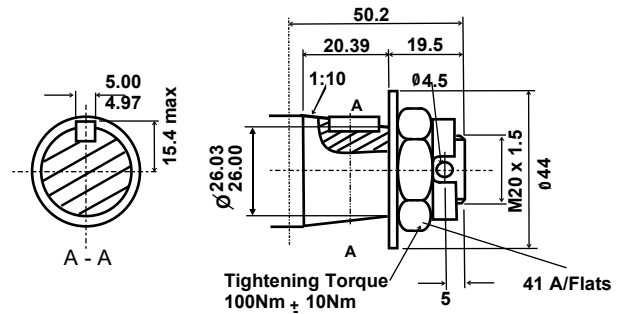

Splined Shaft - SP

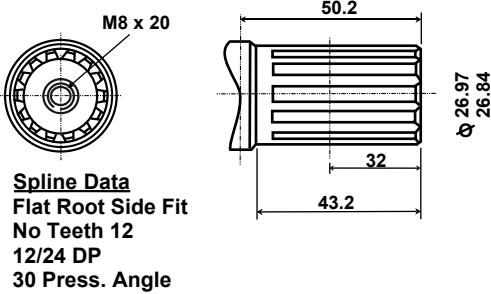

Metric Shaft - M28

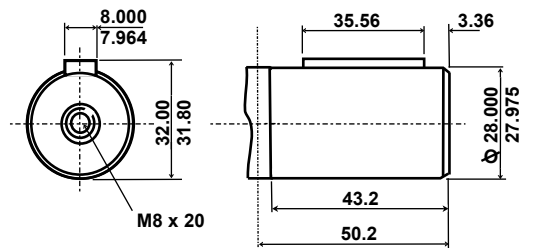

Splined Shaft - SS

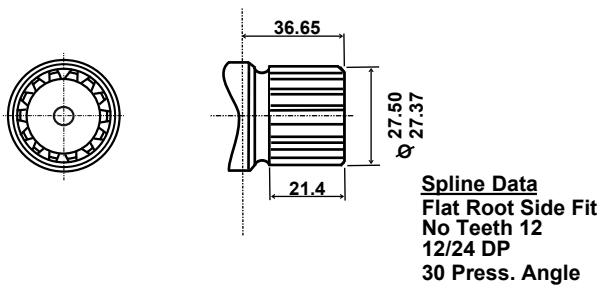

Metric Shaft - M24

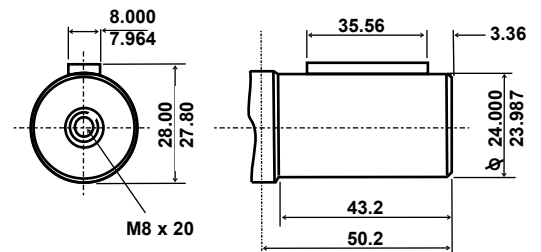

Note Torque limitations

Shafts M, E & M24 cont. 300 Nm (2660lbf.in) int. 420 Nm (3720 lbf.in)

Shafts M28, S, SP, SS & T cont. 360 Nm (3190 lbf.in) int. 470 Nm (4160 lbf.in)

GENERAL DATA

V SERIES

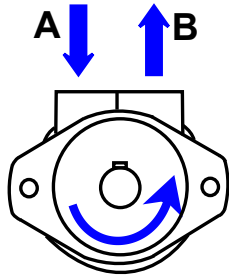
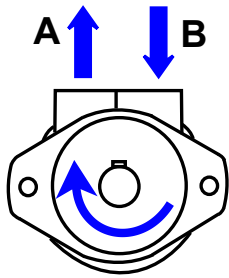

SHAFT ROTATION

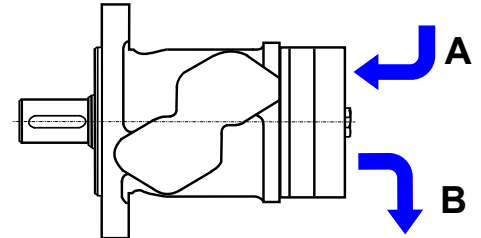
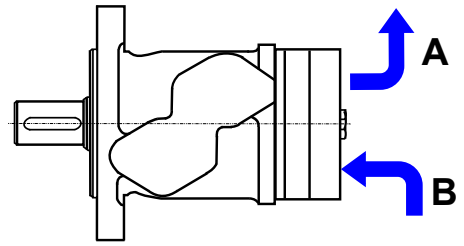

SHAFT LOADING

2 Bolt Flange

$$P = \frac{800}{n} \times \frac{250000}{95 + L} \text{ N}$$

$$P = \frac{800}{n} \times \frac{2215}{3.74 + L} \text{ lbf}$$

4 Bolt Flange

$$P = \frac{800}{n} \times \frac{250000}{101 + L} \text{ N}$$

$$P = \frac{800}{n} \times \frac{2215}{3.98 + L} \text{ lbf}$$

n= speed rpm
For metric L in mm
For imperial L in inches

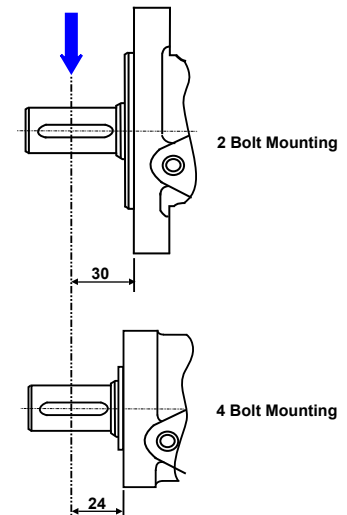
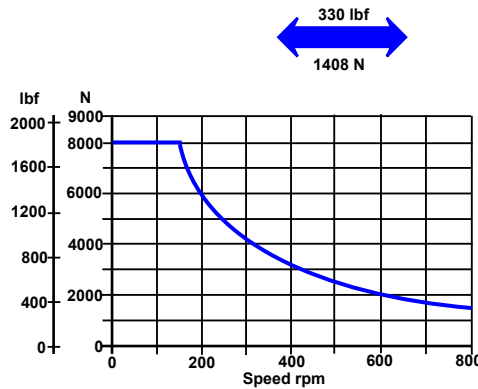

ORDERING CODE

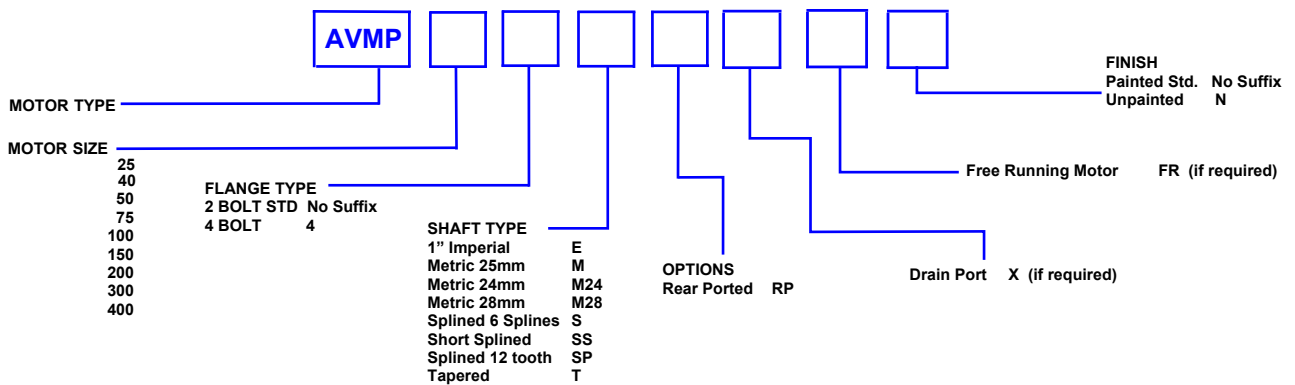

PERFORMANCE GRAPHS 25 & 40 cc V SERIES

Solid blue lines represent continuous operation. Dotted red lines represent intermittent operation permissible for 10% of every minute.

Maximum pressure drop and maximum speed must not occur simultaneously.

Maximum values are dependant on shaft type see note on page 3.

AVMP 25

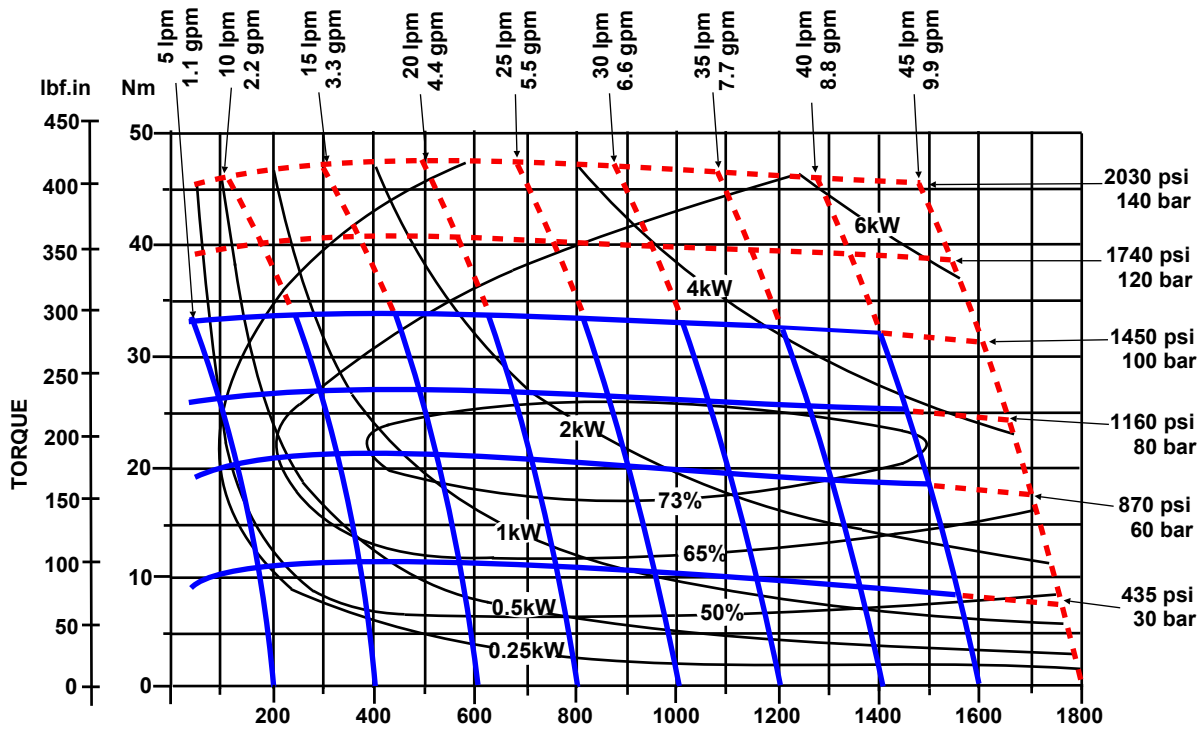

AVMP 40

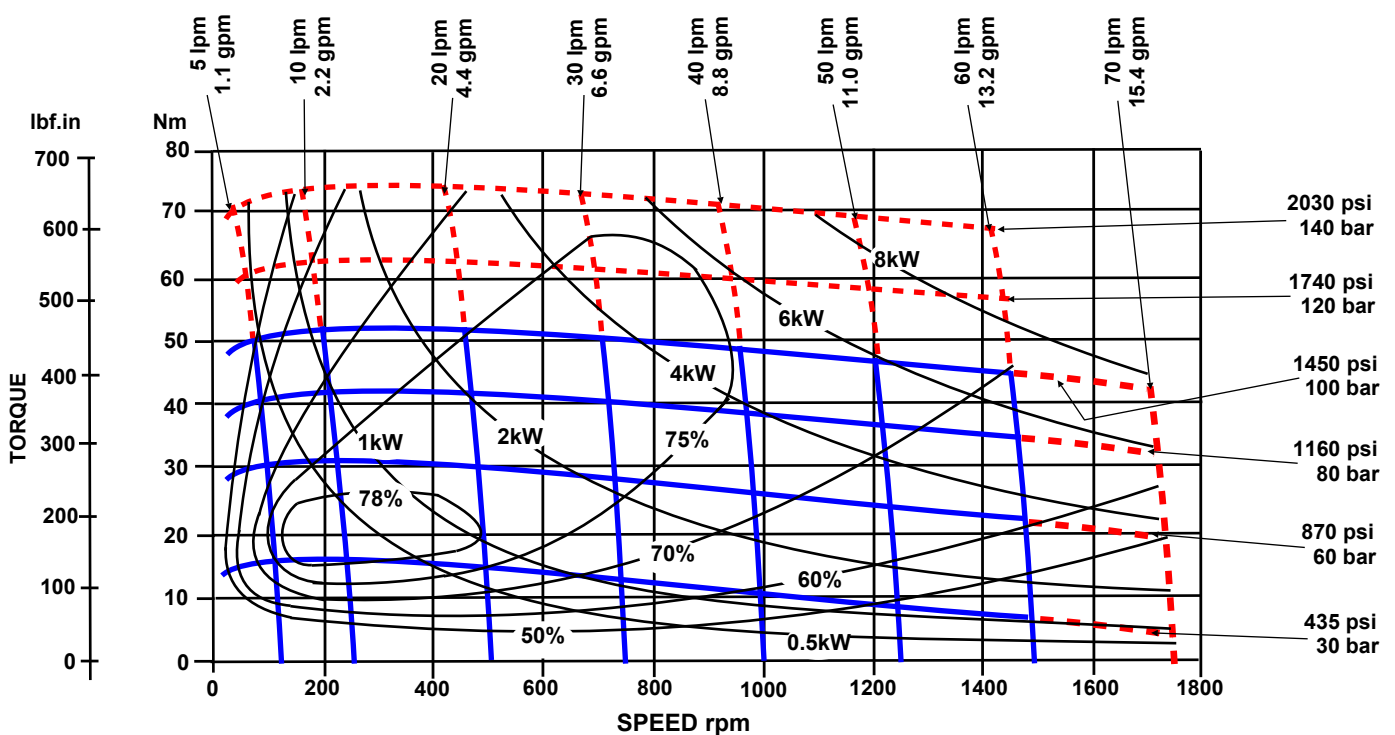

PERFORMANCE GRAPHS 50 & 75 cc

V SERIES

Solid blue lines represent continuous operation. Dotted red lines represent intermittent operation permissible for 10% of every minute.

Maximum pressure drop and maximum speed must not occur simultaneously.

Maximum values are dependant on shaft type see note on page 3.

AVMP 50

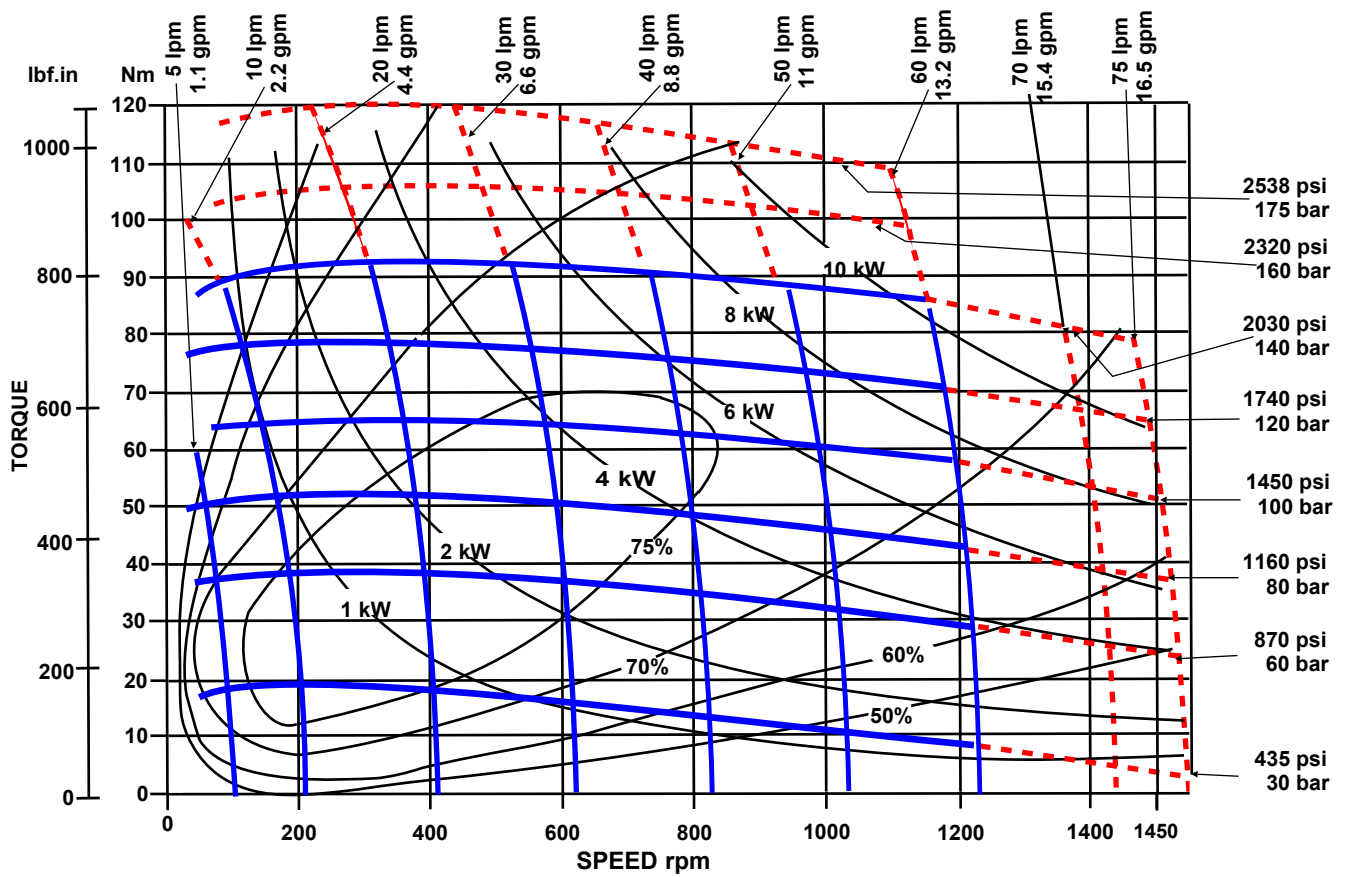

AVMP 75

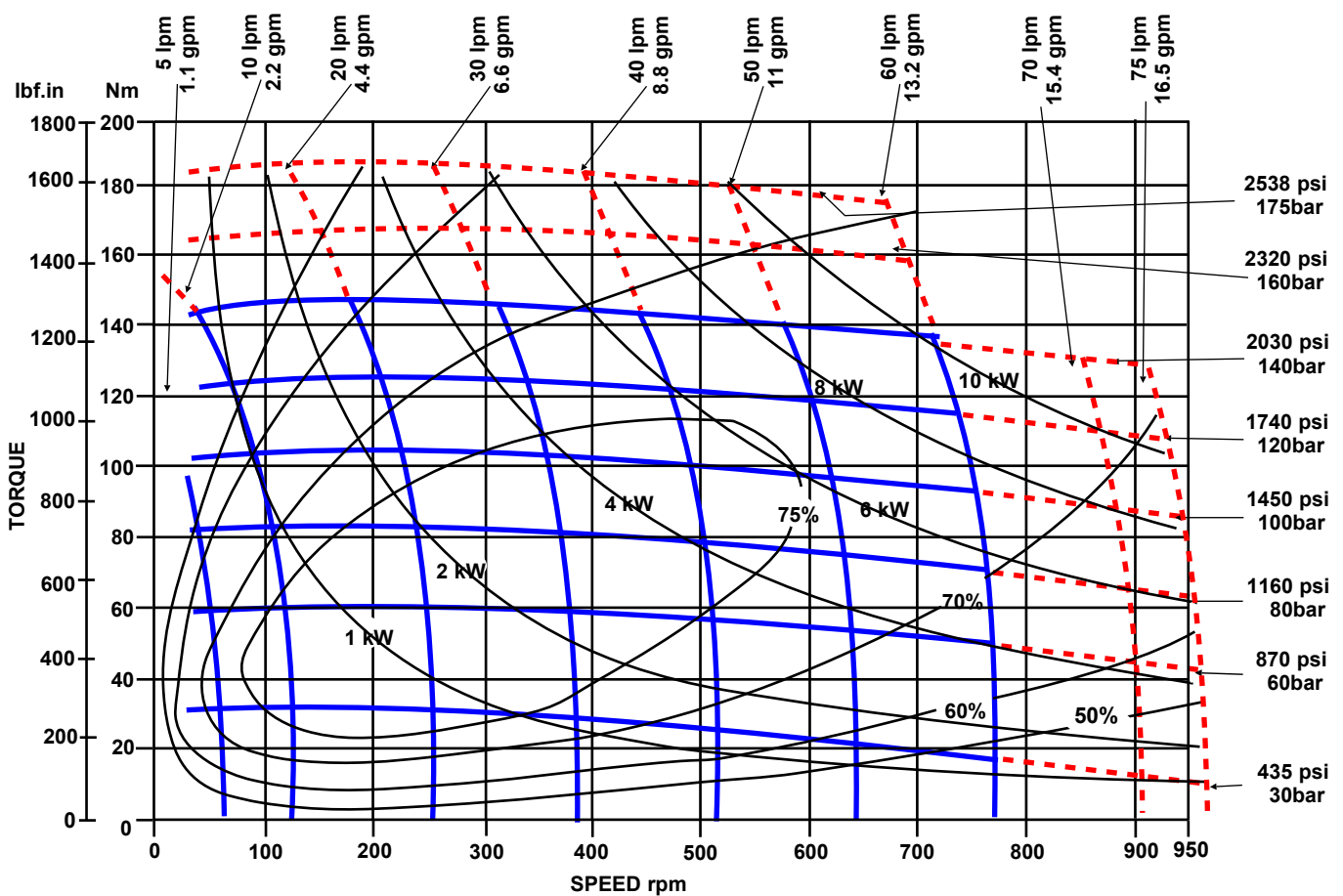

PERFORMANCE GRAPHS 100 & 150 cc V SERIES

Solid blue lines represent continuous operation. Dotted red lines represent intermittent operation permissible for 10% of every minute.

Maximum pressure drop and maximum speed must not occur simultaneously.

Maximum values are dependant on shaft type see note on page 3.

AVMP 100

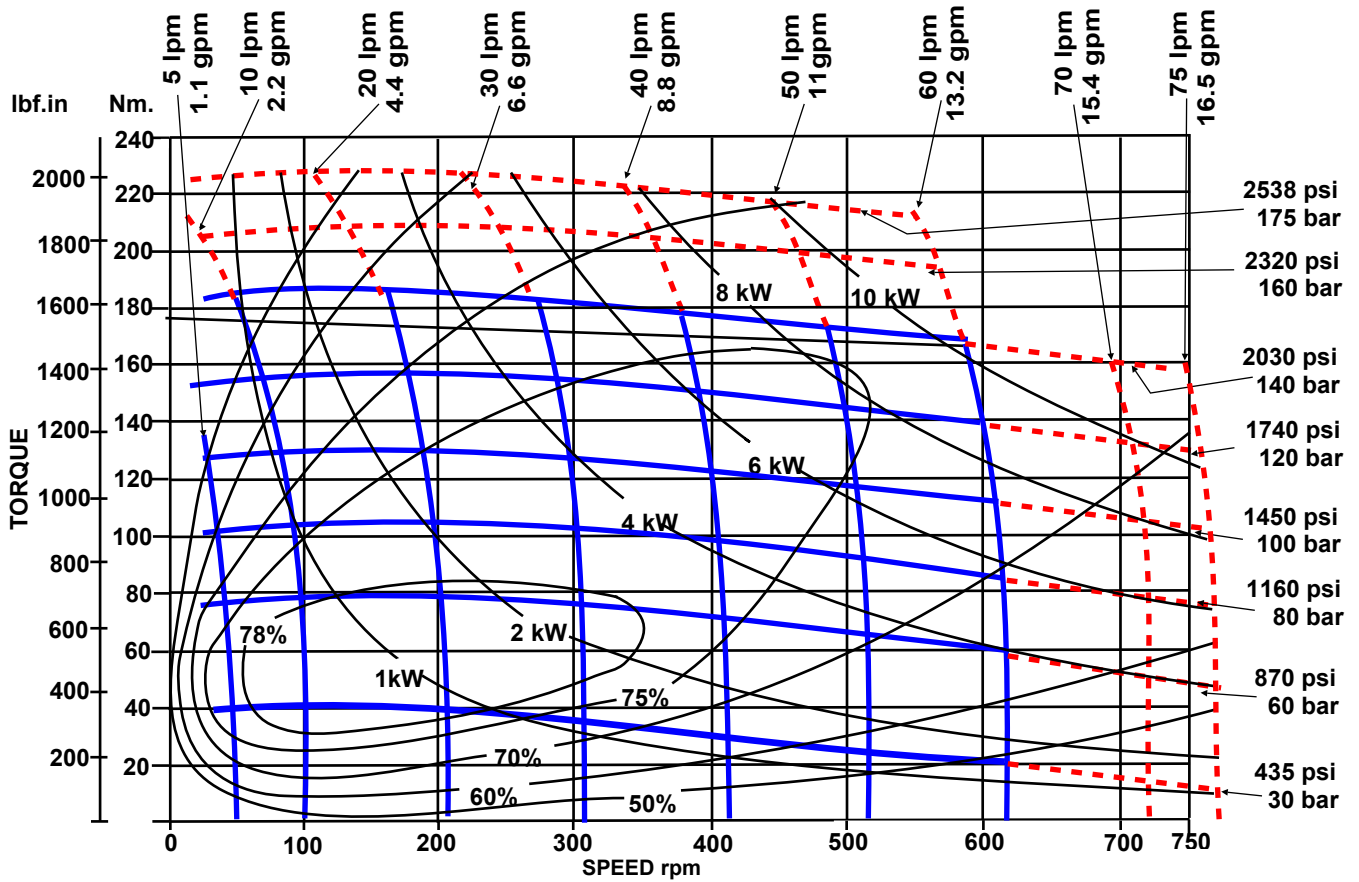

AVMP 150

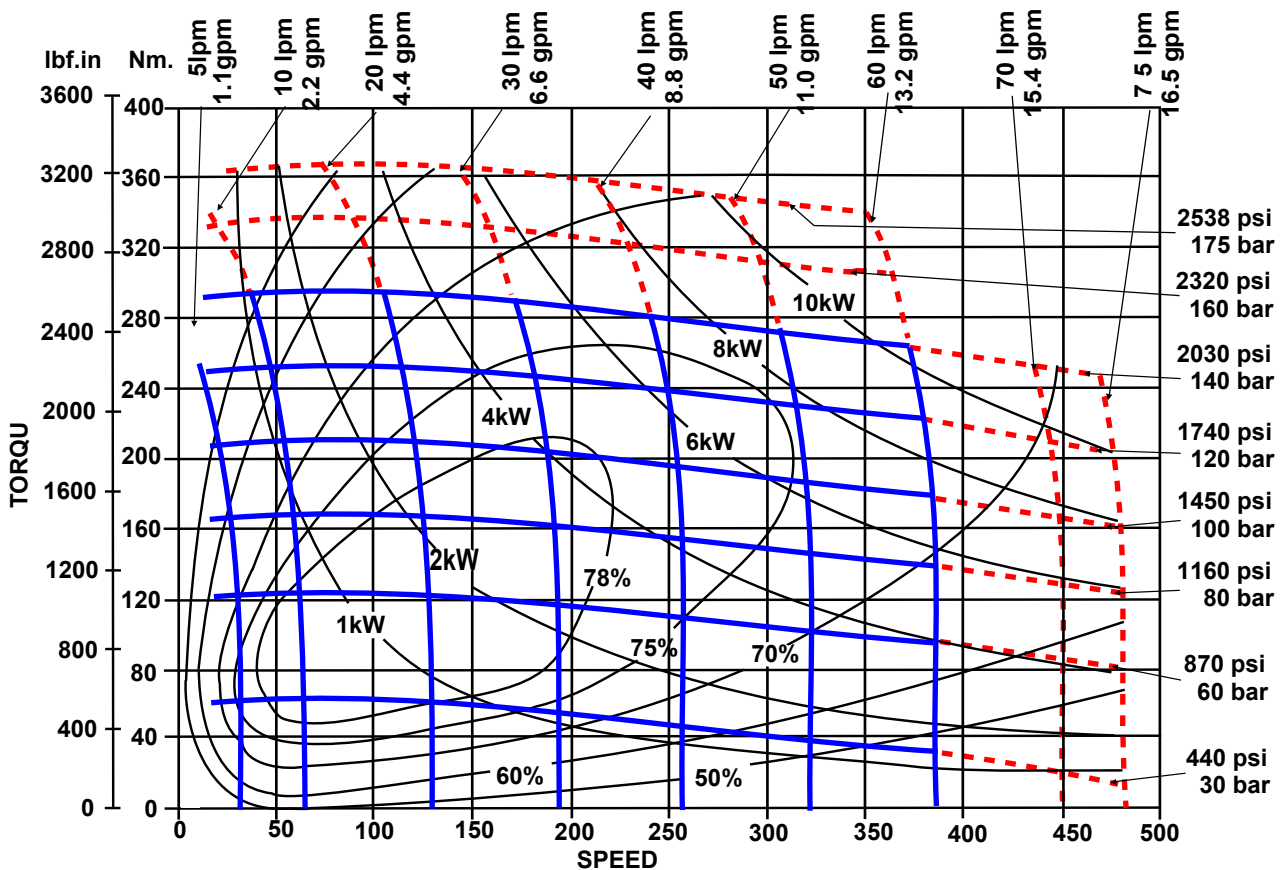

PERFORMANCE GRAPHS 200 & 300 cc V SERIES

Solid blue lines represent continuous operation. Dotted red lines represent intermittent operation permissible for 10% of every minute.

Maximum pressure drop and maximum speed must not occur simultaneously. Maximum values are dependant on shaft type see note on page 3.

AVMP 200

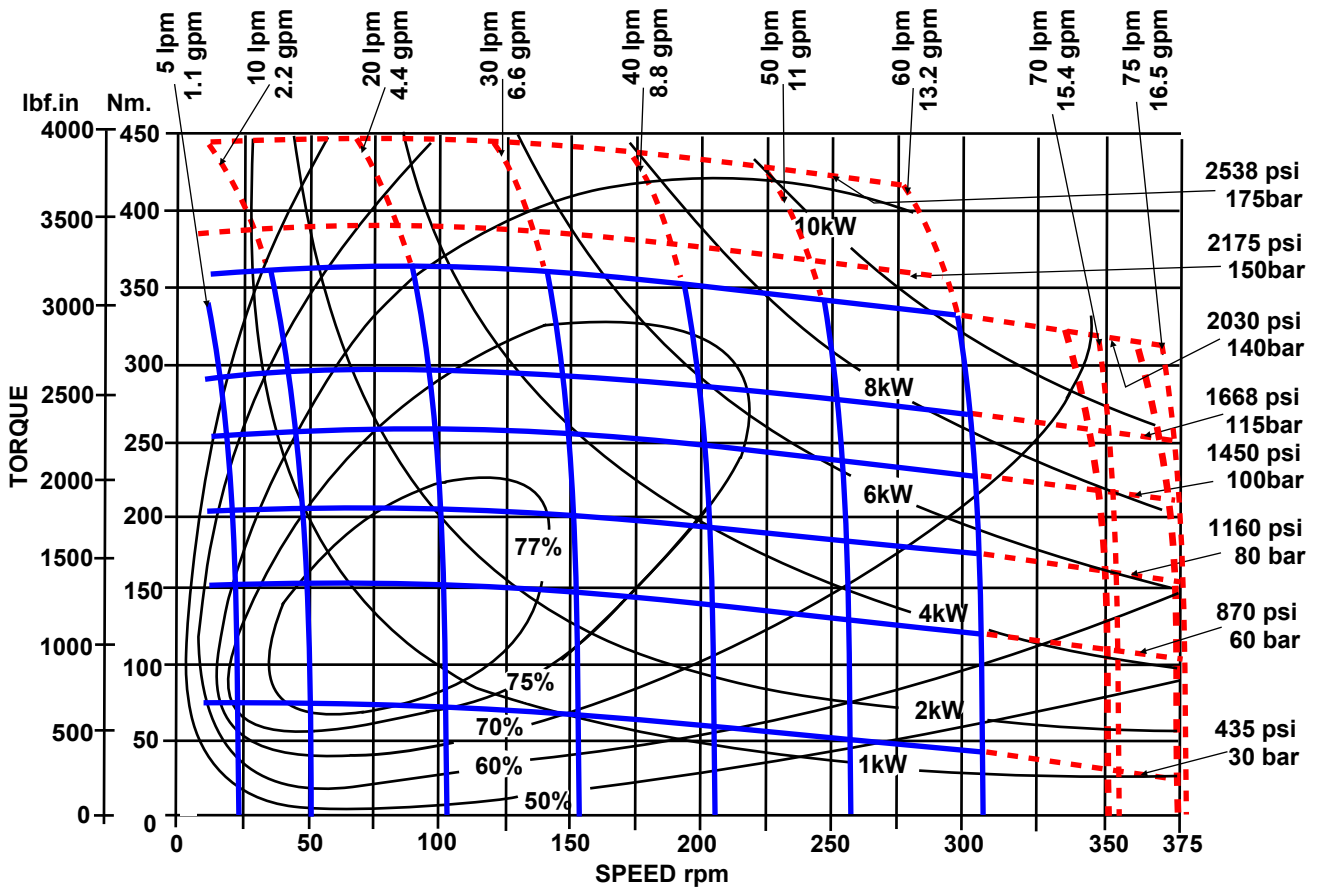

AVMP 300

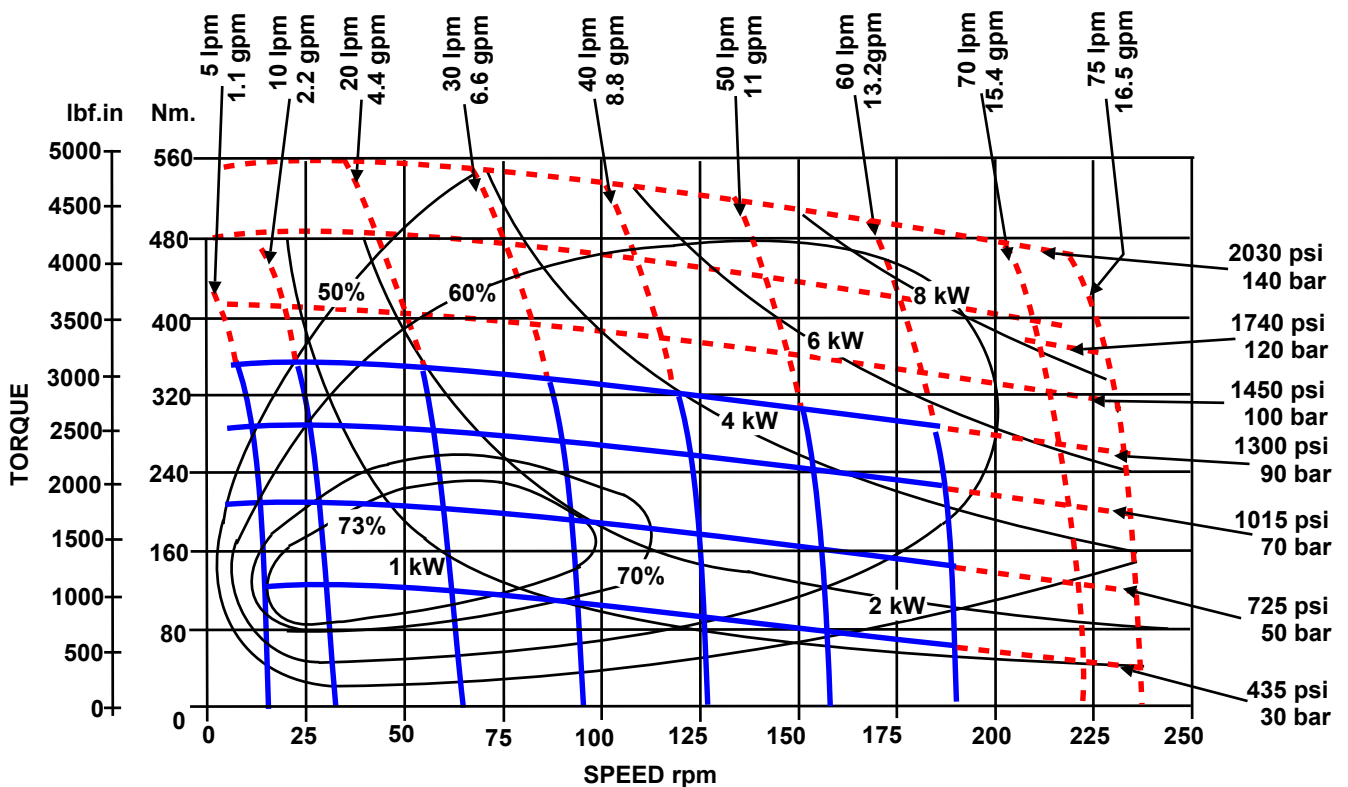

Solid blue lines represent continuous operation. Dotted red lines represent intermittent operation permissible for 10% of every minute.

Maximum pressure drop and maximum speed must not occur simultaneously.

Maximum values are dependant on shaft type see note on page 3.

AVMP 400

