



HYDRAULIC MOTOR REDUCTION UNIT FR35



TYPE		FR35 - AWMP										
MOTOR SIZE		32 W	50 W	63 W	75 W	100 W	125 W	150 W	200 W	250 W	300 W	400 W
DISPLACEMENT per OUTPUT rpm	cm ³	115.5	174.0	230.6	286.3	354.2	441.3	562.8	703.1	877.8	1104.2	1399.6
	in ³	7.07	10.64	14.14	17.53	21.70	27.02	34.48	43.05	53.76	67.62	88.44
MAX. OUTPUT SPEED	rpm cont.	200	200	200	200	171	135	107	85	68	54	45
	rpm int.	240	240	240	240	205	163	128	103	82	65	55
MAX. OUTPUT TORQUE	Nm cont.	154	350	490	530	530	530	530	530	530	530	530
	lbf.in cont.	1363	3097	4336	4690	4690	4690	4690	4690	4690	4690	4690
	Nm int.	185	420	588	636	636	626	636	636	636	636	636
	lbf.in int.	1637	3717	5204	5628	5628	5628	5628	5628	5628	5628	5628
MAX. PRESSURE DROP	bar cont.	100	140	140	140	105	80	65	55	45	30	30
	psi cont.	1450	2030	2030	2030	1522	1160	942	797	652	435	435
	bar int.	140	168	168	168	125	105	95	65	54	45	40
	psi int.	2030	2436	2436	2436	1812	1522	1377	942	783	652	580
MAX. OIL FLOW	lpm cont.	23	35	45	55	60	60	60	60	60	60	60
	gpm cont.	5	7.7	9.9	12.1	13.2	13.2	13.2	13.2	13.2	13.2	13.2
	lpm int.	32	43	55	65	70	75	75	75	75	75	70
	gpm int.	7	9.5	12.1	14.3	15.4	16.5	16.5	16.5	16.5	16.5	15.4

TYPE		FR35-AVMP							
MOTOR SIZE		40V	50V	75V	100V	150V	200V	300V	400V
DISPLACEMENT per OUTPUT rpm	cm ³	141.7	173.2	277.2	346.5	554.4	693.0	1108.8	1386.0
	in ³	8.64	10.6	16.9	21.1	33.8	42.3	67.5	84.6
MAX. OUTPUT SPEED	rpm cont.	200	200	200	200	200	200	190	150
	rpm int.	240	240	240	240	240	240	228	180
MAX. OUTPUT TORQUE	Nm cont.	182	329	525	530	530	530	530	530
	lbf.in cont.	1610	2922	4646	4690	4690	4690	4690	4690
	Nm int.	218	394	630	636	636	636	636	636
	lbf.in int.	2540	3681	5575	5628	5628	5628	5628	5628
MAX. PRESSURE DROP	bar cont.	100	140	140	120	75	60	40	30
	psi cont.	1450	2030	2030	1740	1087	870	580	435
	bar int.	120	168	168	144	90	72	48	36
	psi int.	1740	2436	2436	2088	1305	1044	696	522
MAX. OIL FLOW	lpm cont.	26	34	54	60	60	60	60	60
	gpm cont.	5.7	7.5	12	13.2	13.2	13.2	13.2	13.2
	lpm int.	32	41	65	72	72	72	72	72
	gpm int.	7	9	14.3	15.8	15.8	15.8	15.8	15.8

Maximum continuous output torque 530Nm

Reduction Ratio 3.5-1

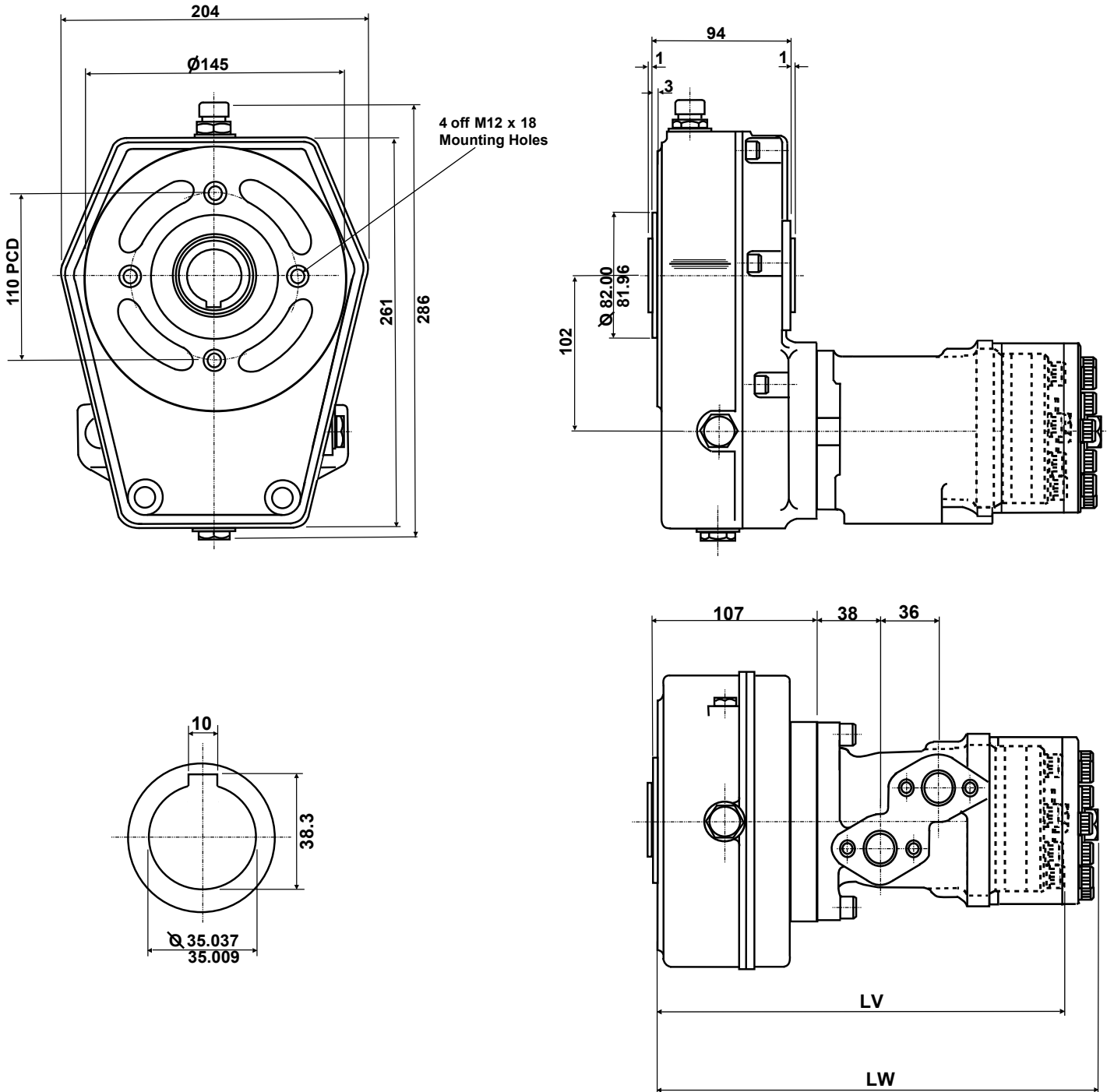

Note! Reduction Unit is shipped dry.

Fill with EP oil with anti foaming additives before use. Select the grade appropriate to temperature from chart based on ISO 3448. It is recommended to replace the oil after the first 50 hours, then every 1000 hours or 6 months.

Fit breather in highest port.

Viscosity	Ambient Temperature °C
ISO VG 150	-10 > +30
ISO VG 220	+10 > +45
ISO VG 320	+30 > +60

FR35	SIZE	32	40	50	63	75	100	125	150	200	250	300	400
FR35 LV	mm	242.1	243.7	243.0	247.8	247.0	249.6	258.3	257.6	263.0	280.1	279.0	289.6
FR35 LW	mm	242.1	243.7	245.0	247.8	250.8	254.0	258.3	264.4	271.3	280.1	291.3	306.1
FR35B LV	mm	356.1	357.7	357.0	361.8	361.0	363.6	372.3	371.6	377.0	394.1	393.0	403.6
FR35B LW	mm	356.1	357.7	359.0	361.8	364.8	368.0	372.3	378.4	385.3	394.1	405.3	420.1
FR35 V	Kg	14.7	14.5	14.6	15.2	14.7	14.8	15.8	15.0	15.3	17.0	15.7	16.0
FR35 W	Kg	14.7	14.7	14.9	15.2	15.3	15.6	15.8	16.0	16.5	17.0	17.4	18.4
FR35B V	Kg	23.7	23.5	23.6	24.2	23.7	23.8	24.8	24.0	24.3	26.0	24.7	25.0
FR35B W	Kg	23.7	23.7	23.9	24.2	24.3	24.6	24.8	25.0	25.5	26.0	26.4	27.4

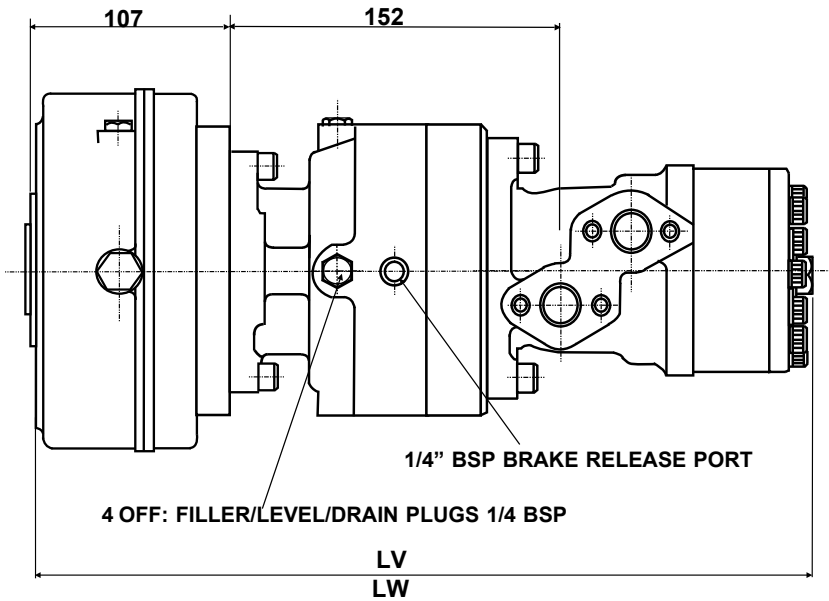

FR35 B
 Static brake torque 450 Nm (3950lbf.in)
 Brake release pressure 25 bar (360psi)

Note! Brake Unit is shipped dry
 Fill with 120cc hydraulic oil
 before use.
 Fit breather in highest drain port.

FR35B
 SYMBOL c/w MSV

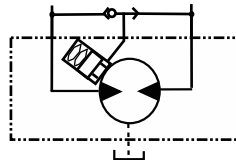

Basic Motor Detail

Spring applied pressure release
 Static brake torque 3950 lbf.in - 450 Nm
 Brake release pressure 380 psi - 26 bar
 Maximum brake pressure 300 bar
 Motor drain line must be used, back to tank
 without obstruction.

Maximum inlet pressure 3250 psi - 224 bar
 Maximum pressure drop and speed must not be reached simultaneously.
 Intermittent operation may occur for 10% max. of every minute.

At speeds lower than 10 rpm please consult our Technical Department.
 Mineral based hydraulic fluids with anti-wear additives are recommended
 with a viscosity of 35 mm²/s at a temperature of 50 °C.
 Minimum recommended oil viscosity 13 mm²/s at operating temperature.
 Recommended oil cleanliness ISO 19/14 with a nominal filtration of
 25 micron or better.
 Where non-flammable fluids are to be used it is advisable to consult our
 Technical Department.
 Ambient temperature should be between -30°C and +90°C.
 Normal operating temperature should be between +30°C and +60°C.
 Maximum operating temperature +85°C.

Motor / Brake Precautions

To ensure proper operation of the brake, a separate case
 drain back to tank must be used due to the possibility of
 return line pressure spikes. A simple schematic of a system
 utilizing a motor/ brake is shown in the diagram below.

To achieve proper brake release operation, it is necessary
 to bleed out any trapped air and fill brake release cavity and
 hoses before all connections are tightened.
 It is advisable that the brake release port should be
 positioned as near the top of the unit in the installed position.

Caution

All Adan motor / brakes are intended to operate as static
 parking brakes, the system should be designed to bring the
 load to a stop before the brake is applied.
 With large displacement motors it is possible for the motor
 to produce higher torques than the brake will hold, it is
 critical that the maximum system pressure is limited in these
 applications. It is vital that the system relief be set low enough
 to ensure the motor is not able to produce more torque than
 the brake can hold.
 Failure to do so may result in serious injury or death.

Incorporating the Adan high torque hydraulic motor this compact 3.5:1 ratio gearbox further extends the range of applications for hydrostatic drives. These units are built to operate under the most arduous conditions for long periods with the minimum of maintenance and have been successfully employed in the Industrial, Mobile, Agricultural, Mining & Marine fields.

SHAFT ROTATION

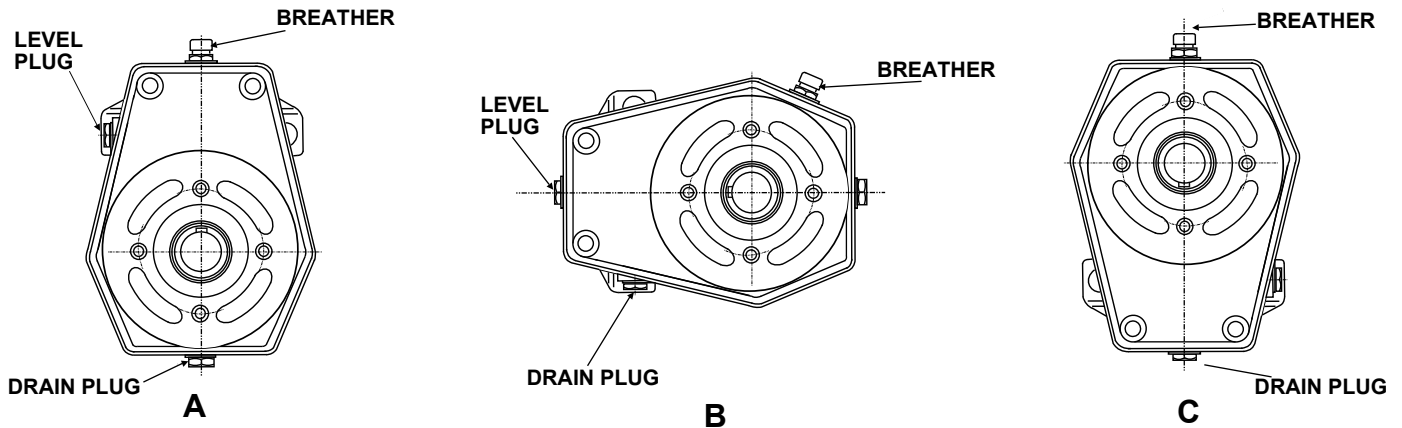
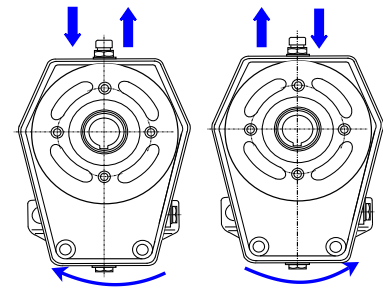

Oil Capacities A 0.52 litres, B 0.80 litres, C 0.34 litres

Average Life

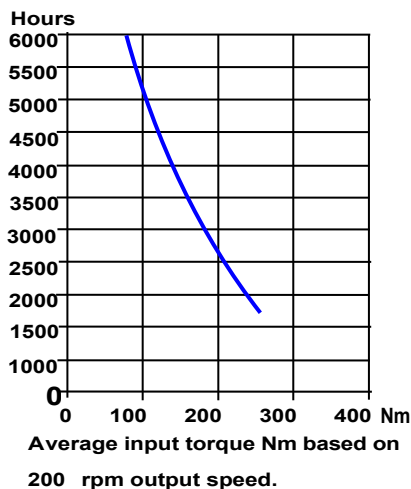

Maximum output torque is determined by life expectation of the system. Please refer to the graph above and the Performance graphs for AVMP/AWMP series motors.

ORDERING CODE

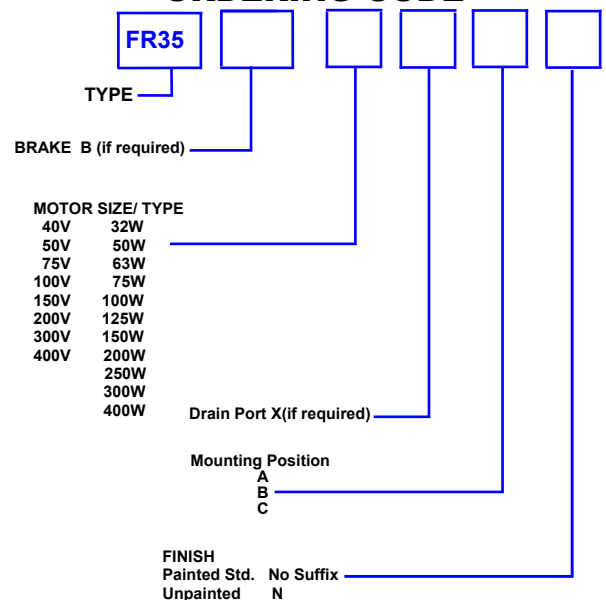

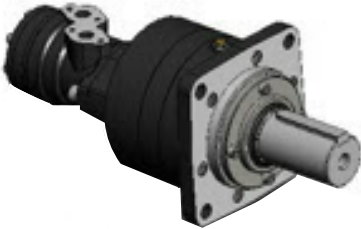

MMG5 SERIES

HYDRAULIC MOTOR

REDUCTION UNIT 5:1 RATIO



TYPE		MMG5-AWMP & MMG5B-T										
MOTOR SIZE		32 W-T	50 W-T	63 W-T	75 W-T	100 W-T	125 W-T	150 W-T	200 W-T	250 W-T	300 W-T	400 W-T
DISPLACEMENT per OUTPUT rpm	cm ³	165.0	248.5	329.5	409.0	506.0	630.5	804.0	1004.5	1254.0	1577.5	1999.5
	in ³	10.10	15.20	20.20	25.05	31.00	38.60	49.25	61.50	76.80	96.60	126.35
MAX. OUTPUT SPEED	rpm cont.	280	155	150	150	120	95	75	60	48	38	32
	rpm int.	320	200	200	188	150	120	90	75	60	48	40
MAX. OUTPUT TORQUE Without Brake	Nm cont.	220	500	700	975	1200	1500	1800	1800	1800	1800	1800
	lbf.in cont.	1947	4450	6200	8628	10620	13275	15930	15930	15930	15930	15930
	Nm int.	310	650	850	1100	1400	1700	2150	2200	2350	2350	2300
MAXIMUM OUTPUT TORQUE With Brake	lbf.in int.	2750	5750	7520	9735	12390	15045	19027	19470	20797	20797	20355
	Nm cont.	220	500	675	975	1200	1500	1500	1500	1500	1500	1500
	lbf.in cont.	1947	4425	5973	8628	10620	13275	13275	13275	13275	13275	13275
MAX. PRESSURE DROP	bar cont.	100	140	140	175	175	175	165	130	100	85	70
	psi cont.	1450	2030	2030	2540	2540	2540	2392	1885	1450	1232	1015
	bar int.	140	175	175	200	200	200	200	175	140	115	90
	psi int.	2030	2540	2540	2900	2900	2900	2900	2537	2030	1667	1305
MAX. OIL FLOW	lpm cont.	50	40	50	60	60	60	60	60	60	60	60
	gpm cont.	11	8.8	11	13.2	13.2	13.2	13.2	13.2	13.2	13.2	13.2
	lpm int.	55	50	62	75	75	75	75	75	75	75	75
	gpm int.	12.2	11	13.6	16.5	16.5	16.5	16.5	16.5	16.5	16.5	16.5

TYPE		MMG5-AVMP								
MOTOR SIZE		40V	50V	75V	100V	150V	200V	300V	400V	
DISPLACEMENT per OUTPUT rpm	cm ³	200.0	247.5	396.0	495.0	792.0	990.0	1584.0	1980.0	
	in ³	12.2	15.1	24.2	30.2	48.3	60.4	96.7	120.8	
MAX. OUTPUT SPEED	rpm cont.	410	228	220	220	176	140	110	88	
	rpm int.	470	294	294	276	220	176	132	110	
MAX. OUTPUT TORQUE Without Brake	Nm cont.	260	470	750	950	1500	1500	1500	1500	
	lbf.in cont.	2300	4159	6635	8405	13275	13275	13275	13275	
	Nm int.	370	600	950	1150	1850	1900	1950	2100	
MAXIMUM OUTPUT TORQUE With Brake	lbf.in int.	3275	5310	8407	10177	16372	16815	17257	18585	
	Nm cont.	260	470	750	950	1500	1500	1500	1500	
	lbf.in cont.	2300	4159	6635	8405	13275	13275	13275	13275	
MAX. PRESSURE DROP	bar cont.	100	140	140	140	140	115	75	60	
	psi cont.	1450	2030	2030	2030	2030	2030	1090	870	
	bar int.	140	175	175	175	175	150	100	80	
	psi int.	2030	2538	2538	2538	2538	2175	1450	1160	
MAX. OIL FLOW	lpm cont.	60	60	60	60	60	60	60	60	
	gpm cont.	13.2	3.2	13.2	13.2	13.2	13.2	13.2	13.2	
	lpm int.	70	75	75	75	75	75	75	75	
	gpm int.	15.4	16.5	16.5	16.5	16.5	16.5	16.5	16.5	

Maximum continuous output torque 2750Nm 24300 lbf.in without Brake Unit

Maximum continuous output torque 1500Nm 13275 lbf.in with Brake Unit

DIMENSIONS

TYPE MMG5

MMG5

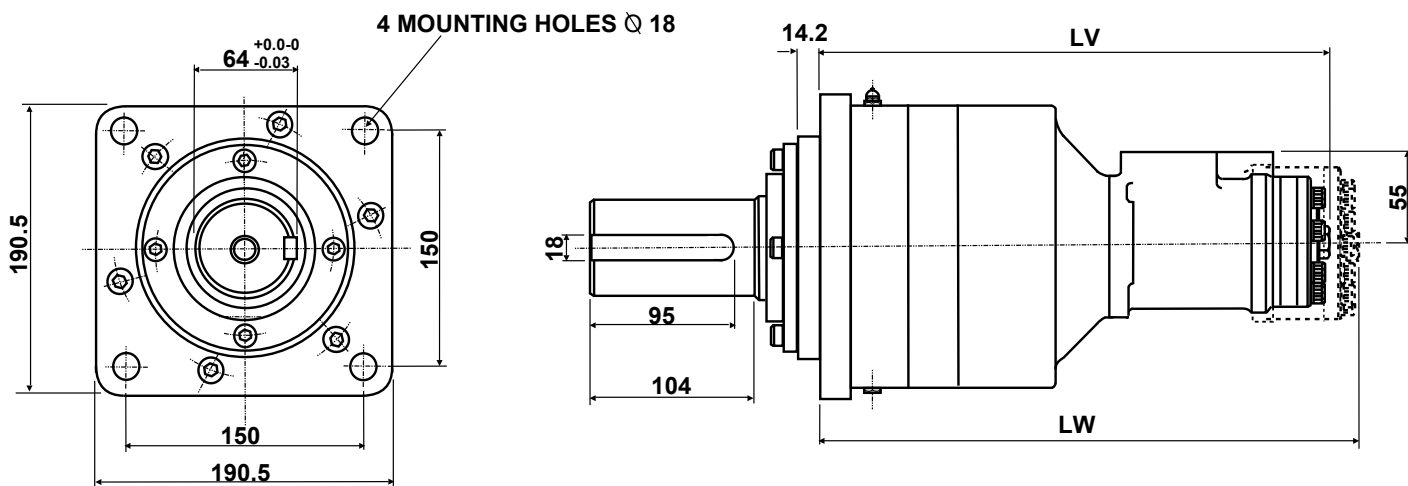

FOR FURTHER MOTOR INFORMATION PLEASE REFER TO 'V', 'W' & 'E' DATA SHEETS

MMG5B SYMBOL c/w MSV

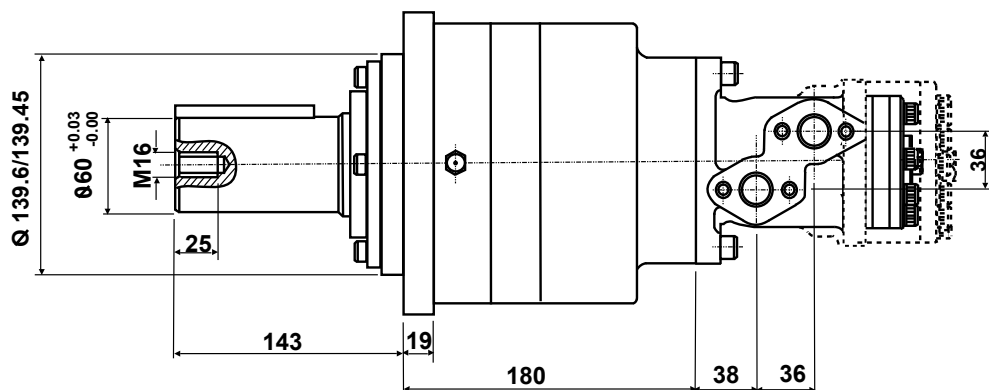
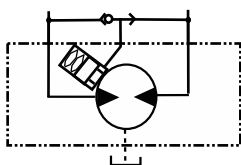

MMG5B

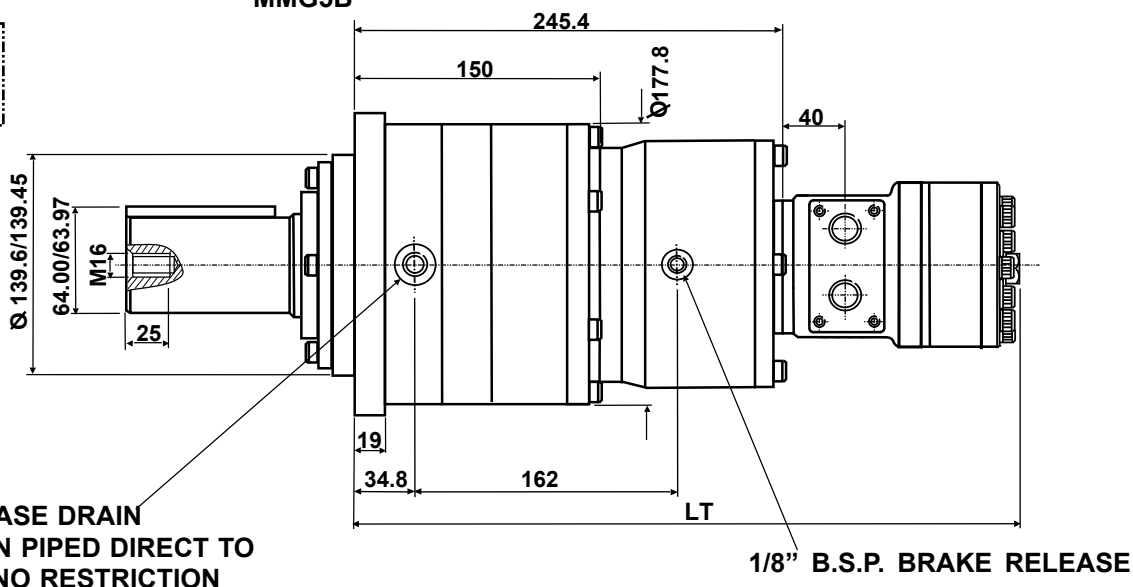

1/4" B.S.P. CASE DRAIN CONNECTION PIPED DIRECT TO TANK WITH NO RESTRICTION

1/8" B.S.P. BRAKE RELEASE

Static brake torque 300 Nm (2655lbf.in)
 Brake release pressure 25 bar (360psi)

For motor performance graphs see 'V, W & E' performance sheets

TYPE	SIZE	32	40	50	63	75	100	125	150	200	250	300	400
MMG5	LV	mm	312.3	311.2	314.4	318.1	326.8	330.3	343.0	355.7			
MMG5	LW	mm	312.5	315.4	318.2	320.4	323.4	325.7	334.4	341.4	350.2	358.4	373.2
MMG5B	LT	mm	363.0	365.9	368.7	371.2	374.6	380.0	384.6	391.9	400.7	409.2	425.9
MMG5	V	Kg	35.2	35.0	35.3	35.4	35.5	35.8	36.2	36.5			
MMG5	W	Kg	35.2	35.4	35.9	35.8	36.1	36.3	36.5	36.6	37.1	37.5	38.5
MMG5B	T	Kg	52.0	52.6	52.9	53.0	53.3	53.5	53.7	54.2	54.7	55.1	56.1

Incorporating the Adan high torque hydraulic motor this compact 5:1 ratio planetary gearbox further extends the range of applications for hydraulic drives. These units are built to operate under the most arduous Conditions for long periods with the minimum of Maintenance and have been successfully employed in the Industrial, Mobile, Agricultural, Mining & Marine fields.

Note MMG5B must be piped to tank without restriction from highest breather port with the exception of position C see note.

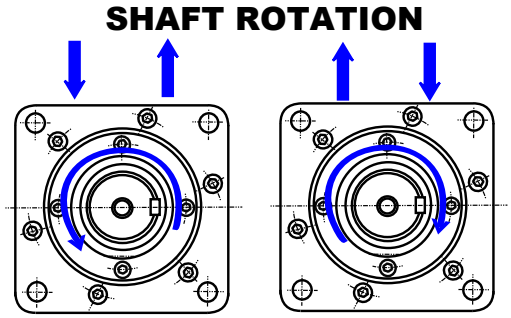

MOUNTING POSITIONS

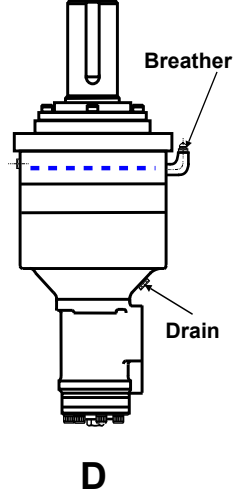
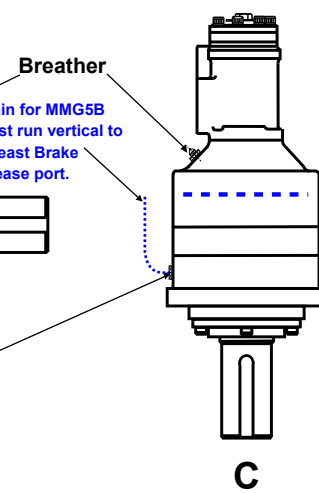
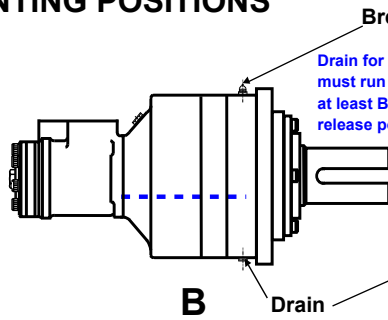
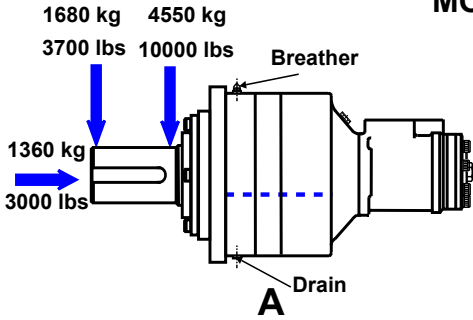

OIL LEVEL

OIL VOLUME A & B 389cc C & D 700cc

Maximum continuous output torque 24300lbf.in (2750Nm) with NO BRAKE

Note MMG5 Units only are shipped dry Fill with EP oil with anti foaming additives before use. Select the grade appropriate to temperature from chart based on ISO 3448. It is recommended to replace the oil after the first 50 hours, then every 1000 hours or 6 months.

Viscosity	Ambient Temperature °C
ISO VG 150	-10 > +30
ISO VG 220	+10 > +45
ISO VG 320	+30 > +60

Fit breather in highest drain port.

MMG5B Units are lubricated by the hydraulic fluid, drain line must be run direct to tank with no restriction.

Basic Motor Detail

Mineral based hydraulic fluids with anti-wear additives are recommended with a viscosity of 35 mm²/s at a temperature of 50 C.

Minimum recommended oil viscosity 13 mm²/s at operating temperature.

Recommended oil cleanliness ISO 19/14 with a nominal filtration of 25 micron or better.

Where non-flammable fluids are to be used it is advisable to consult our Technical Department.

Ambient temperature should be between -30°C and +90°C.

Normal operating temperature should be between +30°C and +60°C.

Maximum operating temperature +85°C.

ORDERING CODE

