



HYDRAULIC MOTOR REDUCTION UNIT with Brake GT25B



TYPE		GT25B						
SIZE		130	160	200	250	300	400	500
DISPLACEMENT per OUTPUT rpm	cm ³	355.0	402.5	502.5	625.0	825.0	1027.5	1310.0
	in ³	21.5	24.5	30.75	38.0	50.5	62.75	80.0
MAX. OUTPUT SPEED	rpm cont.	290	250	250	200	152	120	96
	rpm int.	330	300	300	240	184	144	114
MAX. OIL FLOW	lpm cont.	100	100	125	125	125	125	125
	gpm cont.	22	22	27.5	27.5	27.5	27.5	27.5
	lpm int.	125	125	150	150	150	150	150
	gpm int.	27.5	27.5	33.0	33.0	33.0	33.0	33.0
MAX. PRESSURE DROP	bar cont.	200	200	200	200	200	180	160
	psi cont.	2900	2900	2900	2900	2900	2610	2320
	bar int.	240	240	240	240	240	210	180
	psi int.	3480	3480	3480	3480	3480	3045	2610
MAX. OUTPUT TORQUE	Nm cont.	937.5	1175	1475	1825	2375	2700	2750
	lbf.in cont.	8296.9	10398.7	13053.7	16151.2	21018.7	23895.0	24337.5
	Nm int.	1075	1400	1775	2200	2850	3150	3200
	lbf.in int.	9513.7	12390.0	15708.7	19470.0	25222.5	22877.5	28000.0

Maximum continuous output torque 2750Nm 24337lbf.in

Basic Motor Detail

Maximum inlet pressure 4350 psi - 300 bar

Maximum pressure drop and speed must not be reached simultaneously.

Intermittent operation = 10% Operation of every minute.

Mineral based hydraulic fluids with anti-wear additives are recommended with a viscosity of 35 mm²/s at a temperature of 50°C.

Minimum recommended oil viscosity 13 mm²/s at operating temperature.

Recommended oil cleanliness ISO 19/14 with a nominal filtration of 25 micron or better.

Where non-flammable fluids are to be used it is advisable to consult our Technical Department.

Ambient temperature should be between -30°C and +90°C.

Normal operating temperature should be between +30°C and +60°C.

Maximum operating temperature +85°C.

Basic Brake Detail

Spring applied, pressure release.

Static Capacity 10,000 lbf in. 1130 Nm

Release pressure 450 psi 31 bar



POWERING YOUR WORLD

GT25B

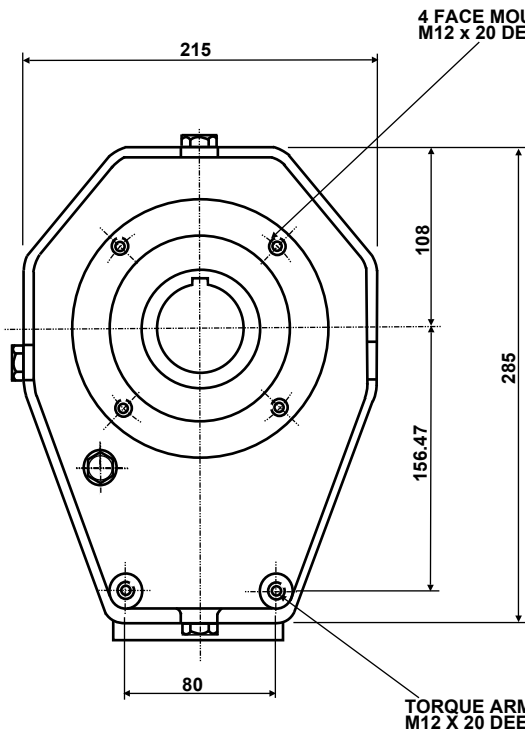

TORQUE ARM FIXINGS
M12 X 20 DEEP

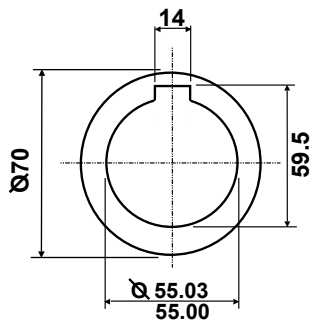
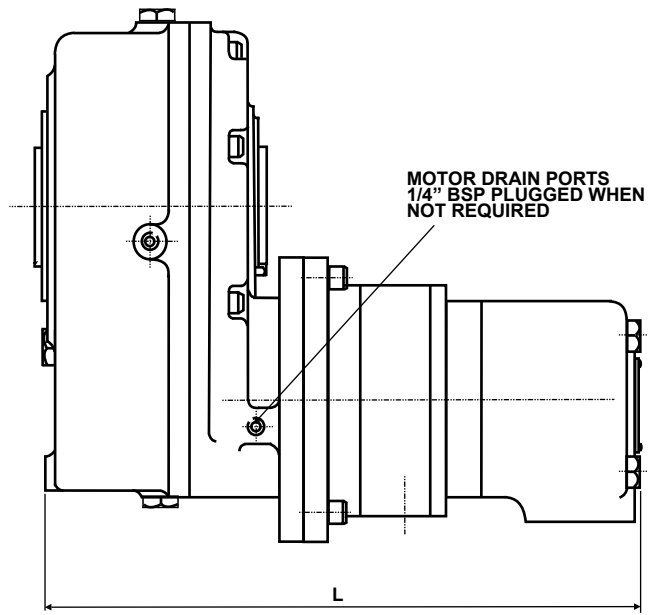

OUTPUT SHAFT

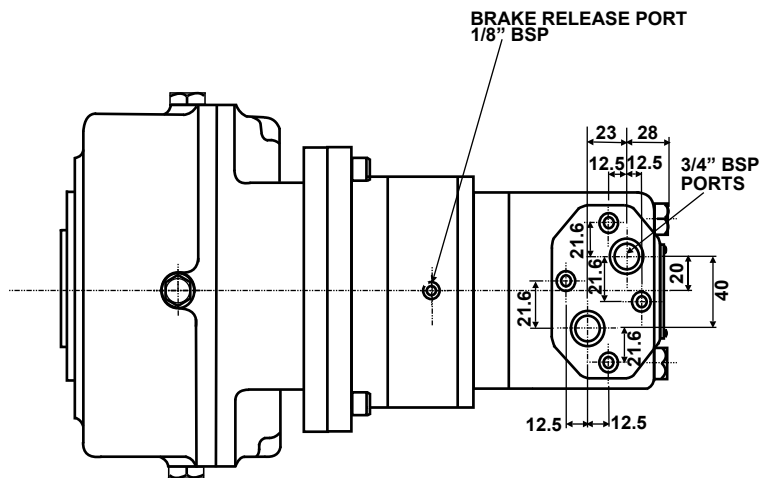

For performance graphs see MT performance sheets

	SIZE	130	160	200	250	300	400	500
GT25B L	mm	380	383	388	394	404	414	428
GT25B WEIGHT	kg	52.8	53.0	54.6	56.5	57.8	58.7	59.6

ORDERING CODE

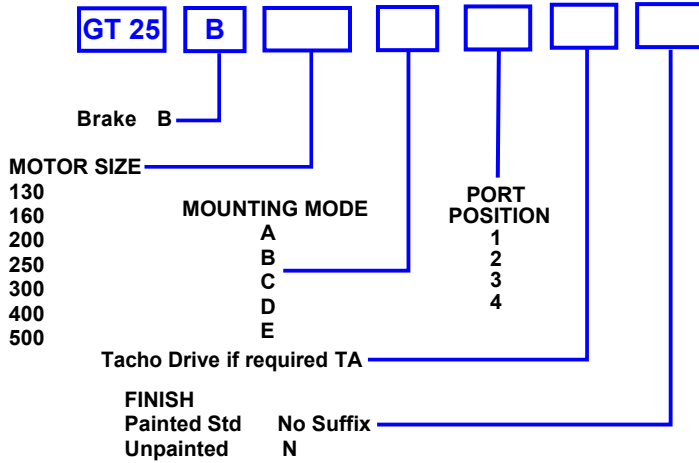

SHAFT ROTATION

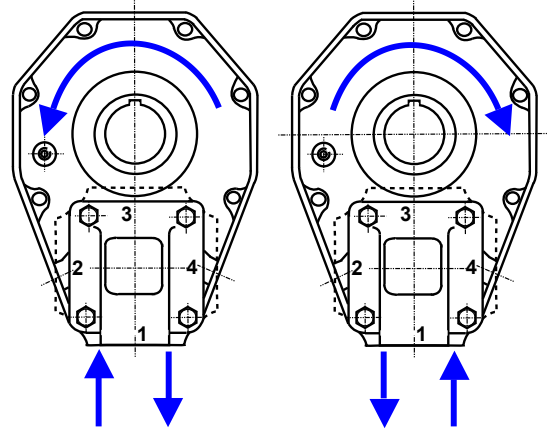

MOUNTING POSITIONS

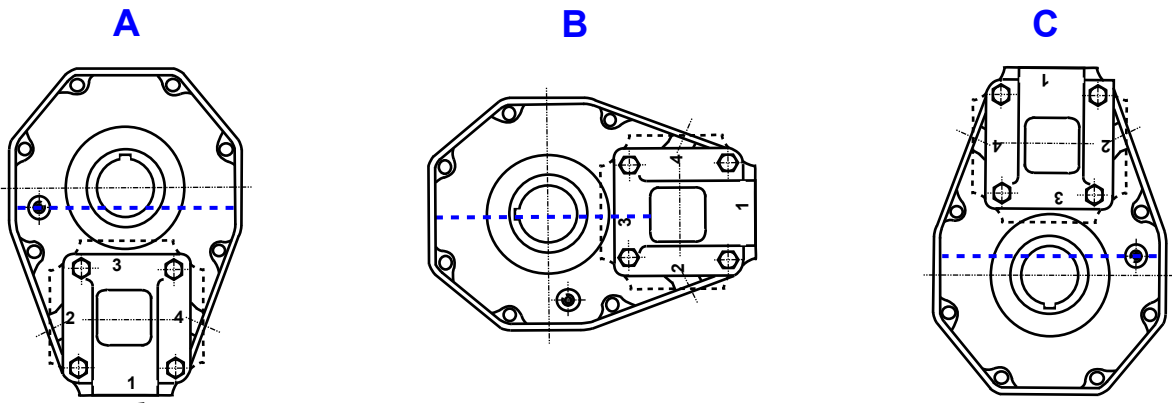

Please select port position 1, 2, 3 or 4

----- Oil level

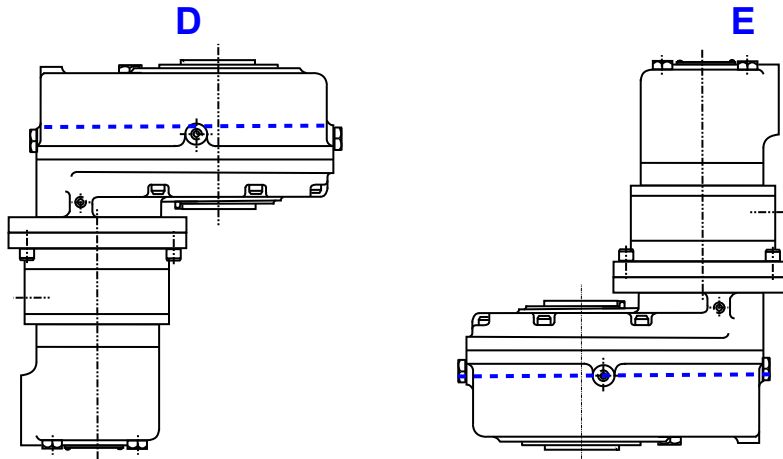

Standard unit are supplied dry, fill with EP90 oil with ant-foaming additives to the levels indicated. In normal applications oil with a viscosity of VG 150(ISO3448) is adequate. Approx. 1.75 litres.

Note all units require the breather plug to be positioned at the highest point before filling.