

# *MTAA SERIES*

## *SAE A Mounting Flange*

### *HYDRAULIC MOTOR*

#### *HIGH TORQUE - LOW SPEED*

TYPE		MTAA SERIES						
MOTOR SIZE		130	160	200	250	300	400	500
DISPLACEMENT	cm <sup>3</sup>	142	161	201	250	330	411	524
	in <sup>3</sup>	8.6	9.8	12.3	15.2	20.2	25.1	32.0
MAX. SPEED	rpm cont.	725	625	625	500	380	300	240
	rpm int.	825	780	750	600	460	360	285
MAX. TORQUE	Nm cont.	375	470	590	730	770	1080	1220
	lbf.in cont.	3320	4160	5220	6460	6815	9560	10800
	Nm int.	470	560	710	880	900	1260	1370
	lbf.in int.	4160	4960	6280	7790	7965	11150	12130
MAX. PRESSURE DROP	bar cont.	200	200	200	200	160	120	105
	psi int.	2900	2900	2900	2900	2320	1740	1522
	bar int.	240	240	240	240	200	140	120
	psi int.	3480	3480	3480	3480	2900	2030	1740
MAX. OIL FLOW	lpm cont.	102	100	125	125	125	125	125
	gpm cont.	22.5	22.0	27.5	27.5	27.5	27.5	75.5
	lpm int.	116	125	151	149.4	152.0	148.0	151.0
	gpm int.	25.6	27.6	33.3	33.0	33.5	32.5	33.0
MTAA	WEIGHT kg	23.5	24.0	24.5	25.0	26.0	27.0	28.0

Maximum inlet pressure 4350 psi - 300 bar  
 High pressure shaft seal drain line not required for most applications.

Maximum pressure drop and speed must not be reached simultaneously.  
 Intermittent operation may occur for 10% max. of every minute.

At speeds lower than 10 rpm please consult our Technical Department.

Mineral based hydraulic fluids with anti-wear additives are recommended with a viscosity of 35 mm<sup>2</sup>/s at a temperature of 50 C.

Minimum recommended oil viscosity 13 mm<sup>2</sup>/s at operating temperature.

Recommended oil cleanliness ISO 19/14 with a nominal filtration of 25 micron or better.

Where non-flammable fluids are to be used it is advisable to consult our Technical Department.

Ambient temperature should be between -30°C and +90°C.

Normal operating temperature should be between +30°C and +60°C.

Maximum operating temperature +85°C.

SYMBOL

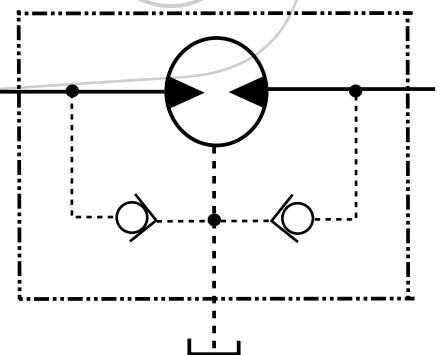

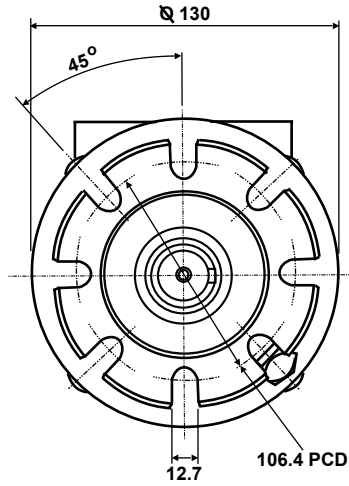

MTAA

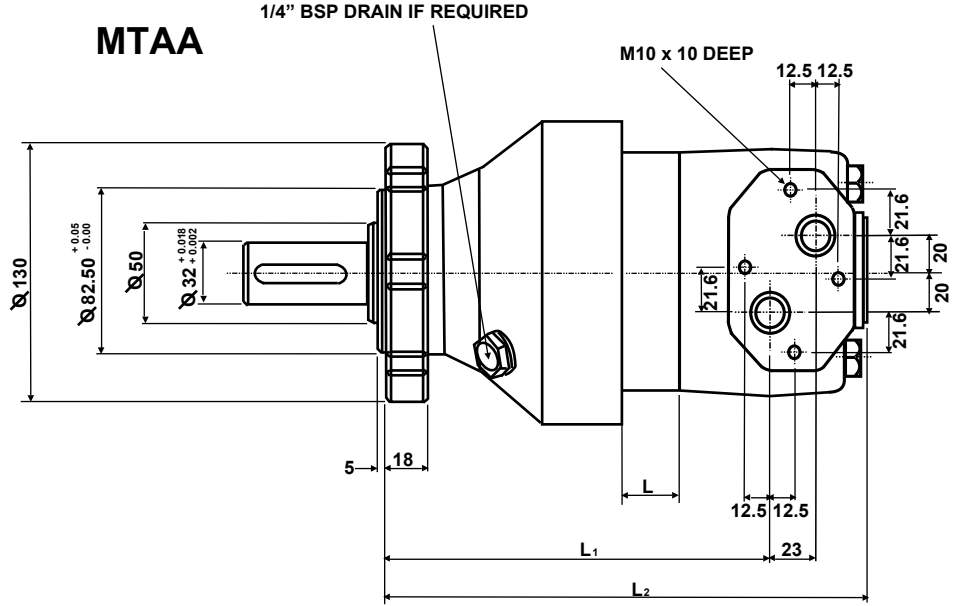

SHAFT LOADINGS

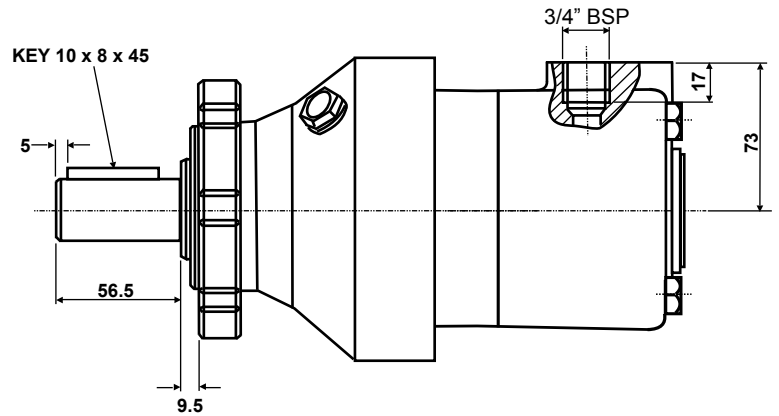
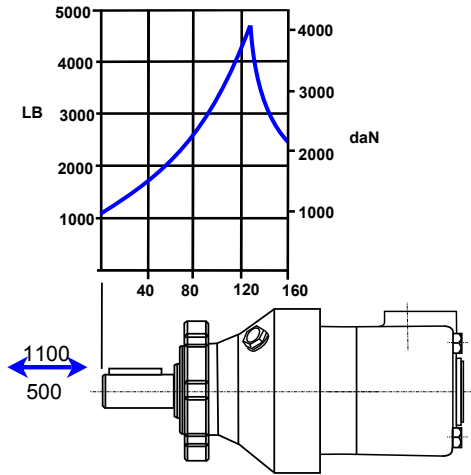

TA

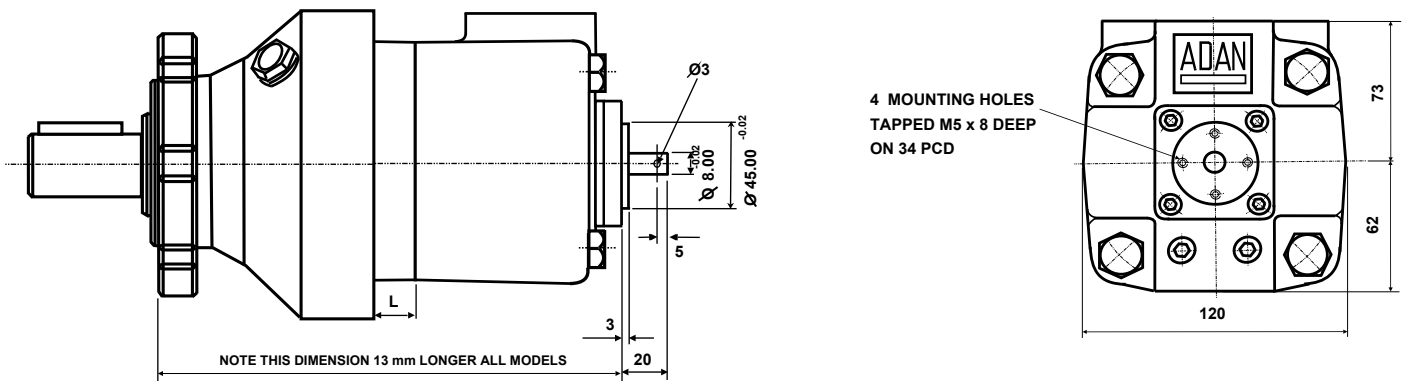

For shaft variations see Page 3

For Performance Graphs see Pages 4-7

MTAA SERIES			130	160	200	250	300	400	500
DIM	L	mm	12	15	20	26	36	46	60
DIM	L 1	mm	161	163	168	172	184	194	208
DIM	L 2	mm	212	214	219	225	235	245	259

**32 mm Shaft - P**

**1 1/4" Shaft - U**

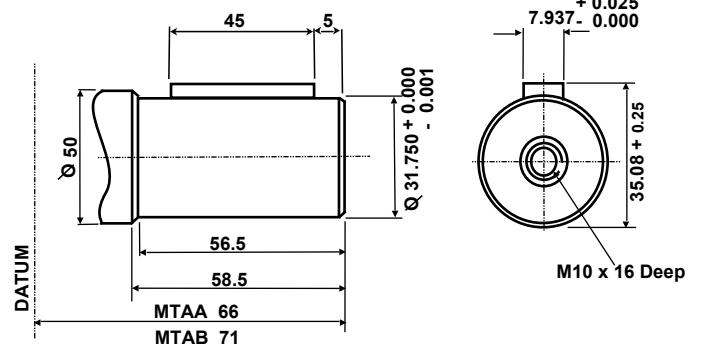
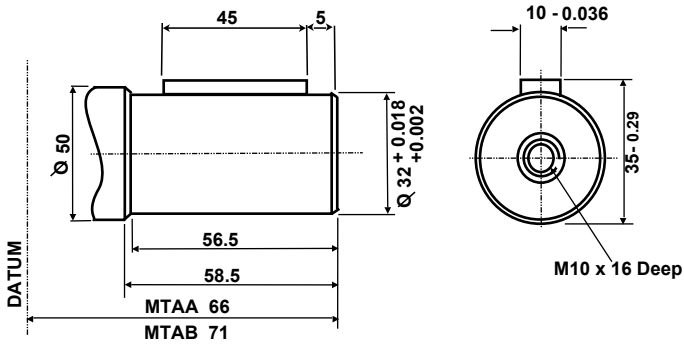

**TORQUE LIMITATIONS FOR SHAFTS TYPE 'P' & 'U'**  
 850 Nm Continuous 1000 Nm Intermittent

**GENERAL DATA**

**MTAA SERIES**

**SHAFT ROTATION**

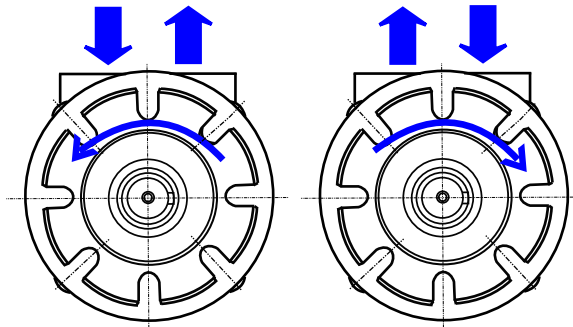

**ORDERING CODE**

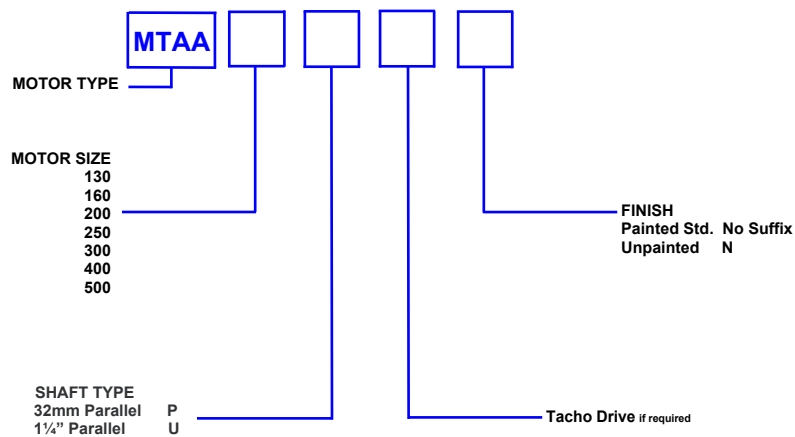

# PERFORMANCE GRAPHS 130 & 160 cc MT SERIES

Solid blue lines represent continuous operation. Dotted red lines represent intermittent operation permissible for 10% of every minute.

Maximum pressure drop and maximum speed must not occur simultaneously.

## MTAA 130

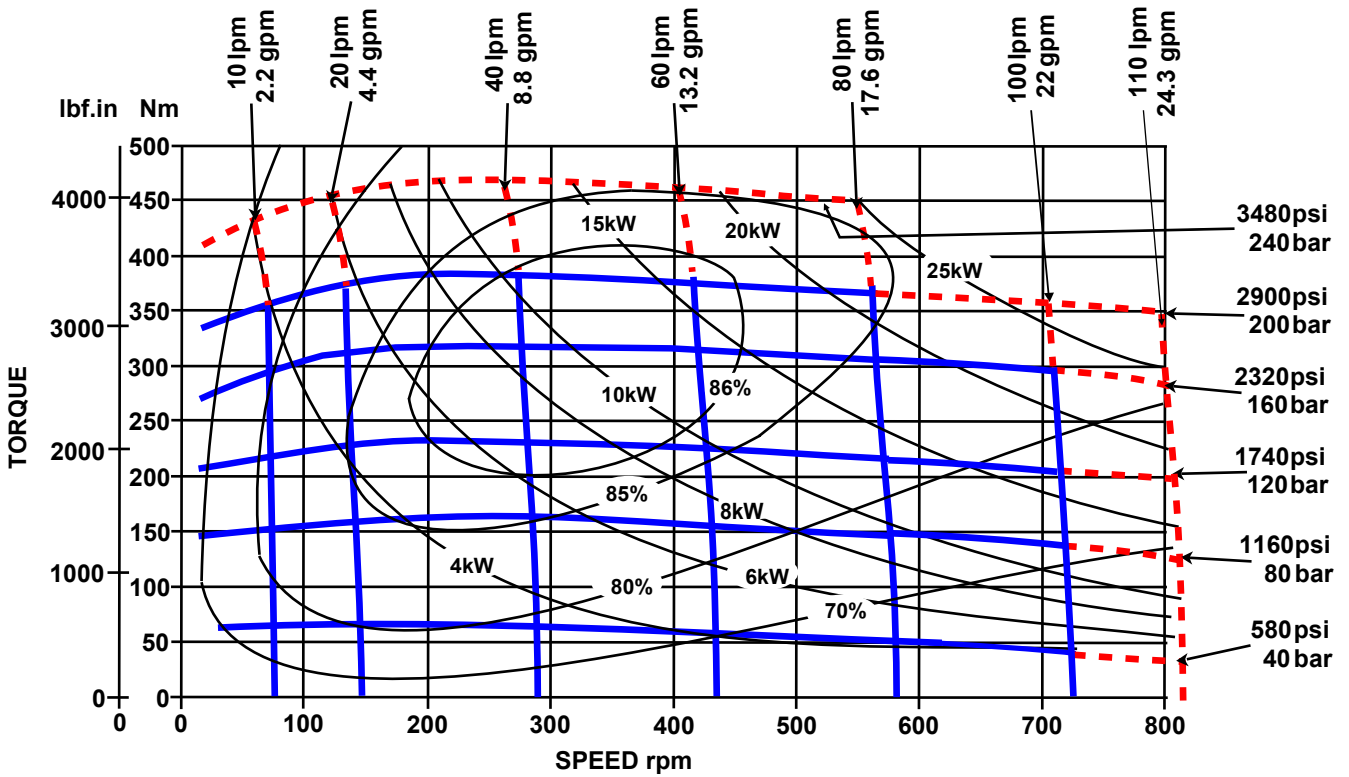

## MTAA 160

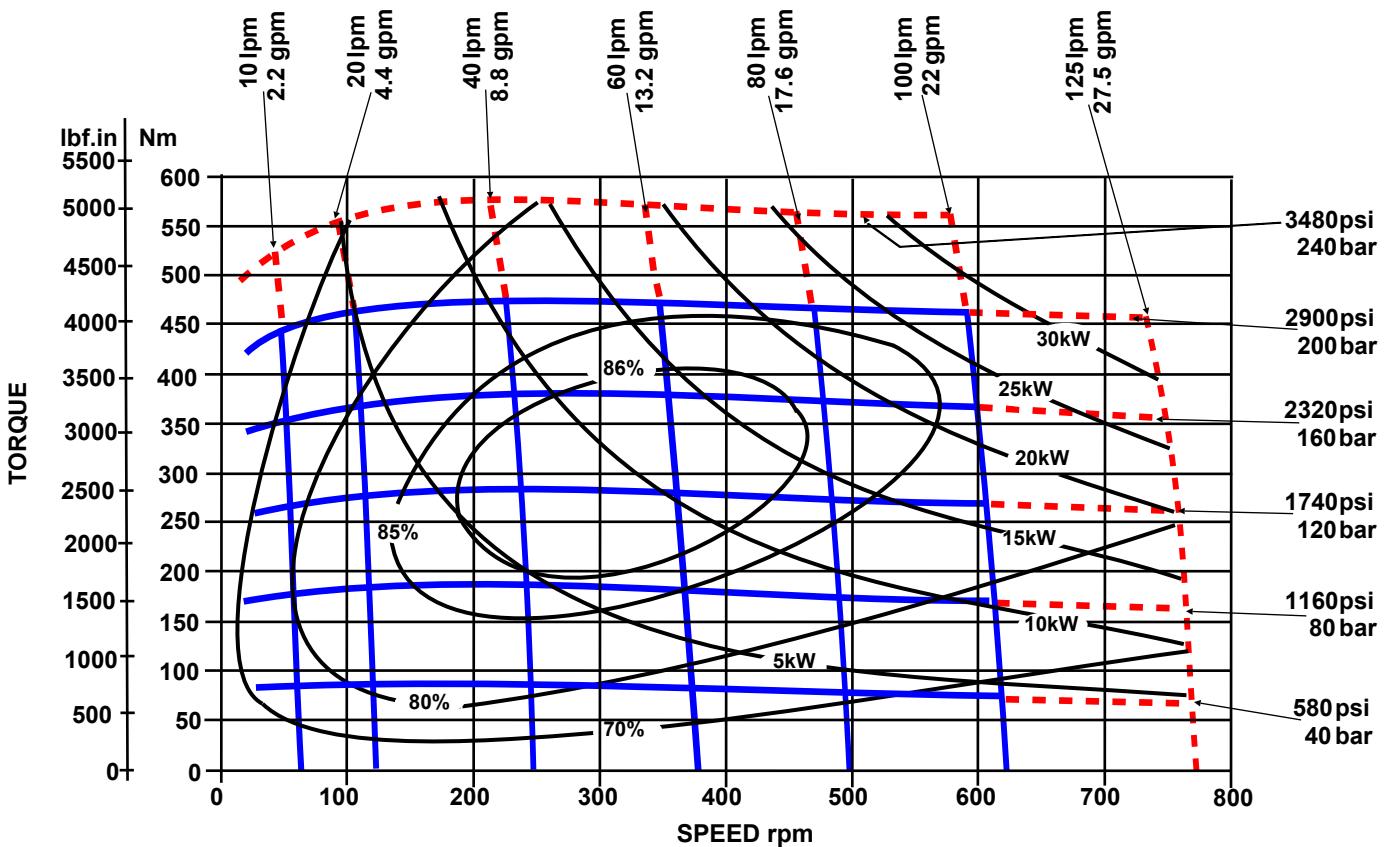

# PERFORMANCE GRAPHS 200 & 250 cc MT SERIES

Solid blue lines represent continuous operation. Dotted red lines represent intermittent operation permissible for 10% of every minute.

Maximum pressure drop and maximum speed must not occur simultaneously.

## MTAA 200

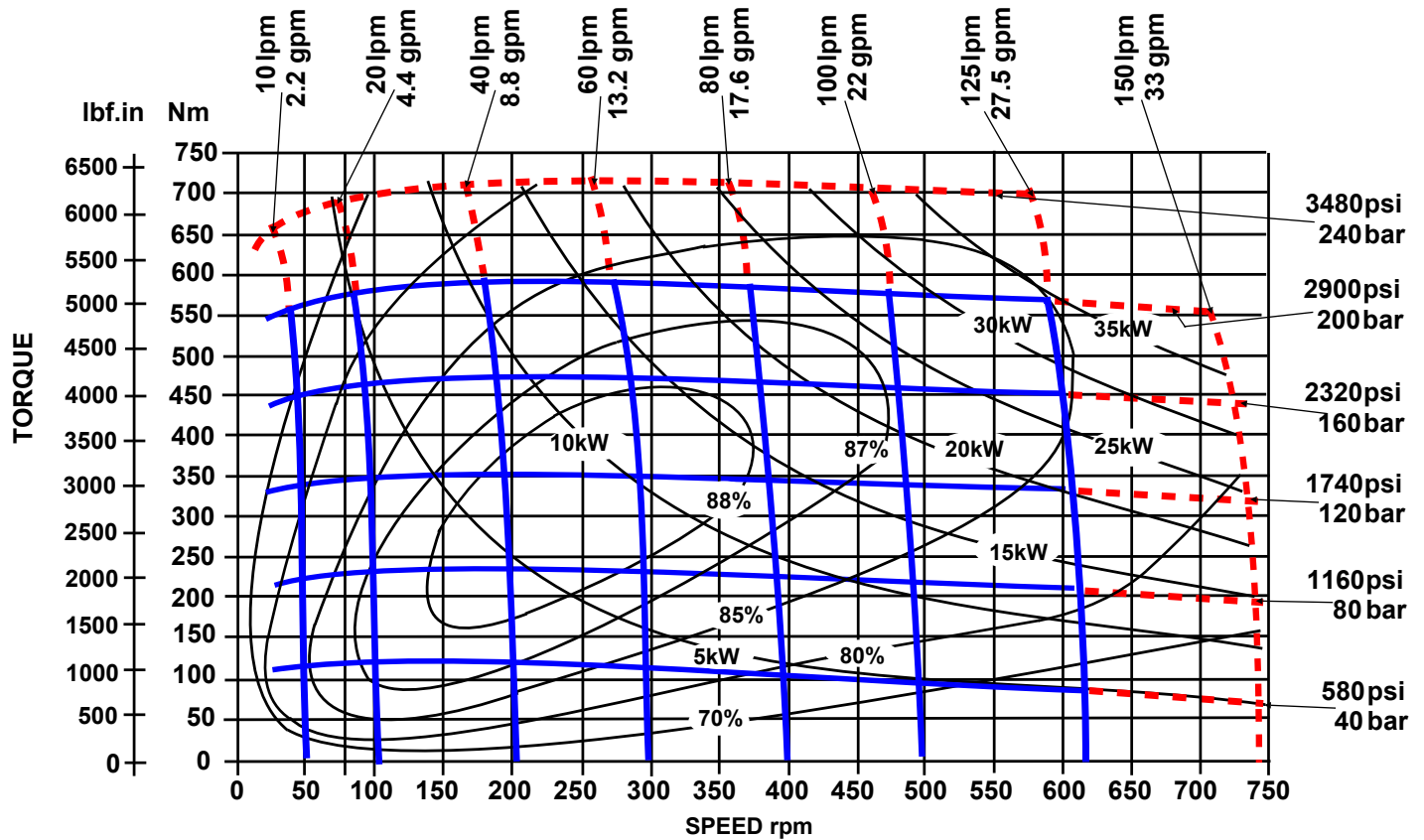

## MTAA 250

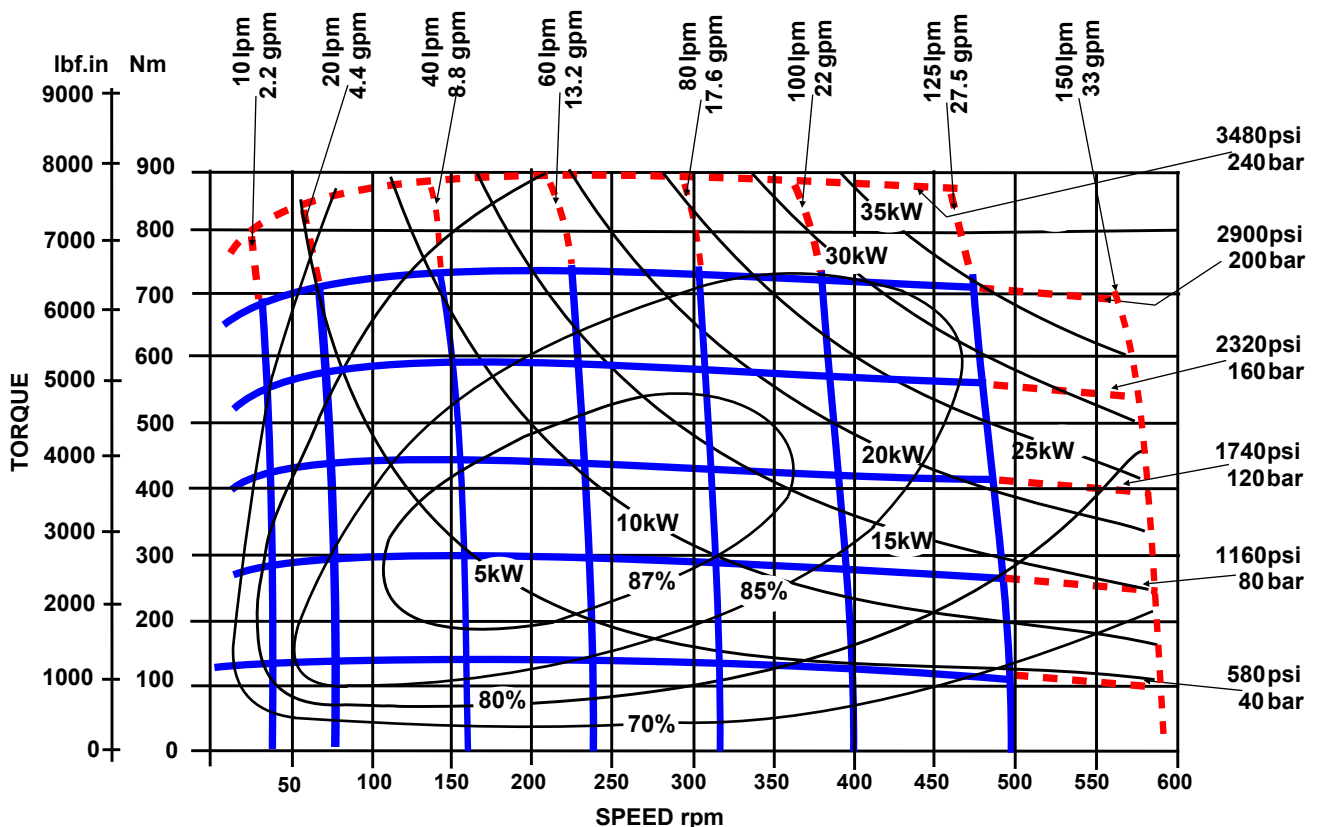

# PERFORMANCE GRAPHS 300 & 400 cc MT SERIES

Solid blue lines represent continuous operation. Dotted red lines represent intermittent operation permissible for 10% of every minute.

Maximum pressure drop and maximum speed must not occur simultaneously.

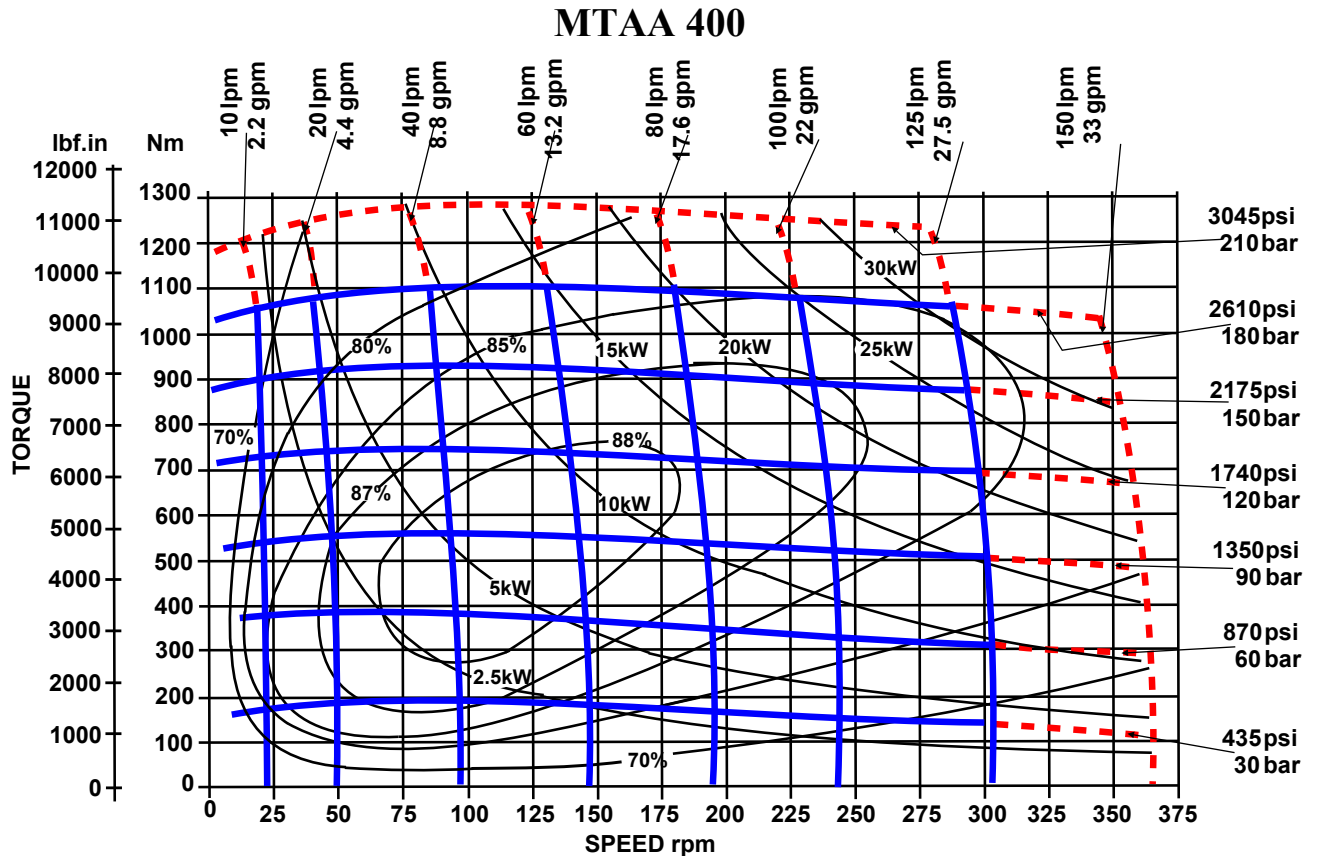
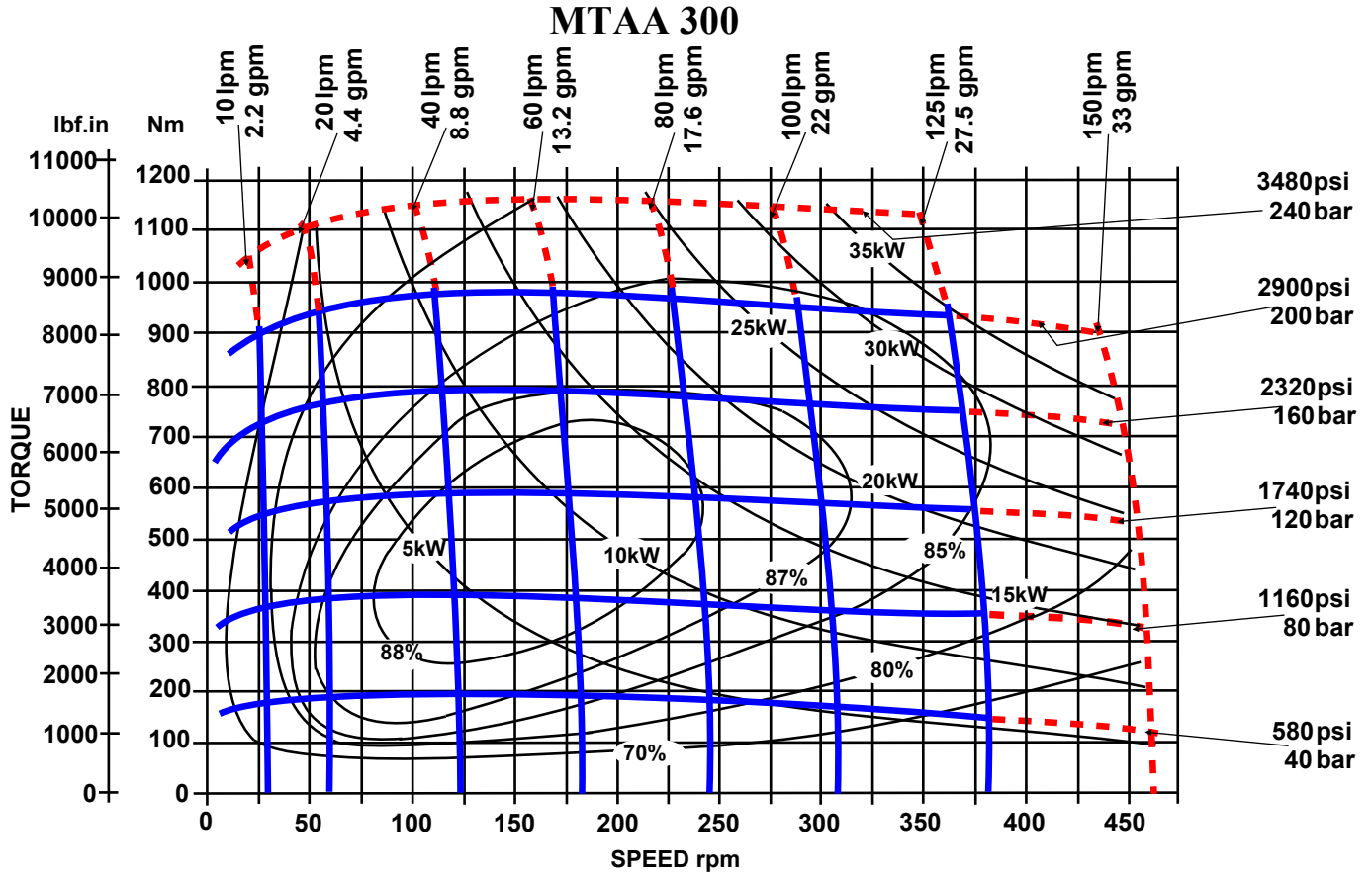

# PERFORMANCE GRAPHS 500 cc MT SERIES

Solid blue lines represent continuous operation. Dotted red lines represent intermittent operation permissible for 10% of every minute.

Maximum pressure drop and maximum speed must not occur simultaneously.

## MTAA 500

